

RuggedNet® GPoE+/Si

Unmanaged Industrial 6 and 10 Port PoE/PoE+ Gigabit Ethernet Switch

The RuggedNet GPoE+/Si is a unmanaged Industrial PoE and PoE+ Ethernet switch that features fiber or copper uplink ports and four or eight 10/100/1000 PoE/PoE+ RJ-45 copper user ports.

The RuggedNet GPoE+/Si is a standard Layer 2 Ethernet switch that forwards frames to any port based on their MAC address.

The RuggedNet GPoE+/Si supports Directed Switch mode, which directs multicast traffic (such as video) only to the appropriate uplink port, preventing the multicast video traffic from flooding other network ports.

Models with two fiber or two copper uplink ports support daisy-chain configurations or redundant uplinks for critical applications that require protection and sub 50ms restoration in the event of an uplink failure.

Models with two fiber or two copper uplink ports also support Dual Device mode that enables the GPoE+/Si to operate as two independent and isolated Ethernet switches. In Dual Device mode, the GPoE+/Si provides separate and independent data traffic paths between the two uplink ports and four or eight user ports.

The RuggedNet GPoE+/Si modes of operation can be configured using easily accessible DIP-switches. Each DIP-switch function is labeled on the top of the RuggedNet for ease of identification and use.

The RuggedNet GPoE+/Si is available with fixed ST, SC, and LC connectors or Small Form Pluggable (SFP) transceivers. Fiber ports support multimode or single-mode and dual fiber or single-fiber with distances up to 140km. SFP models support a variety of distances in standard, CWDM and DWDM wavelengths.

The switches feature a PoE power reset function that enables the attached PD device, such as a camera or access point, to be re-initialized remotely, eliminating the need for costly truck rolls to remote PD sites. When a problem with a PD is detected, the fiber port on the module can be disconnected, triggering the PoE power reset function.

All models can be wall or rack mounted using a wall mount bracket and shelf or DIN-rail mounted using the included DIN-rail mounting clip. They are available with single or dual DC input power options.



SFPs not included

KEY FEATURES

- Unmanaged 6 and 10 port PoE/PoE+ Ethernet switch
- Dual Device mode for operating as two separate switches
- Directed Switch mode prevents flooding of multicast video traffic
- Configurable PoE Power Reset
- Uplink redundancy on models with two uplink ports
- Two 10/100/1000 copper or 100M*/1G fiber uplink ports
- Four or eight 10/100/1000 copper PoE+ user ports
- ST, SC and LC fixed fiber ports or standard, CWDM or DWDM Gigabit SFP transceivers
- Single or dual DC power for redundancy
- Wall, Rack and DIN-rail mountable
- Fan-less design for long life
- Industrial (-40 to 75°C) operating temperature
- TAA, BAA and NDAA compliant, and Made in the USA
- Free 24/7/365 Technical Support

*100Mbps supported with 100M SGMII SFP Transceivers

APPLICATIONS

Daisy Chain Application

This example demonstrates the daisy chain capabilities of the RuggedNet PoE switches. In this application each RuggedNet switch connects to its neighboring switch via its uplink ports. The daisy chain can continue to additional switches using this method of connectivity.

Each RuggedNet switch provides connectivity to the fiber links, and power to IP cameras and Wi-Fi access points at each location along the daisy chain.

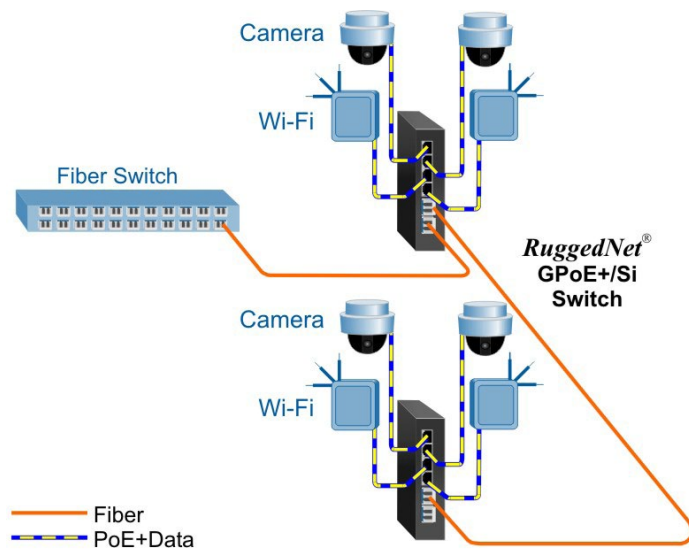

Dual Device Mode Application

This Dual Device feature is extremely useful when two isolated networks domains share a single network distribution location.

The example below depicts a scenario where a surveillance security (purple) network and a Wi-Fi (green) network are sharing a single hub distribution location. Using the two uplinks and the Dual Switch mode facilitates using a single PoE switch driving both the Cameras and the Wi-Fi Access Points while maintaining isolation between the networks.

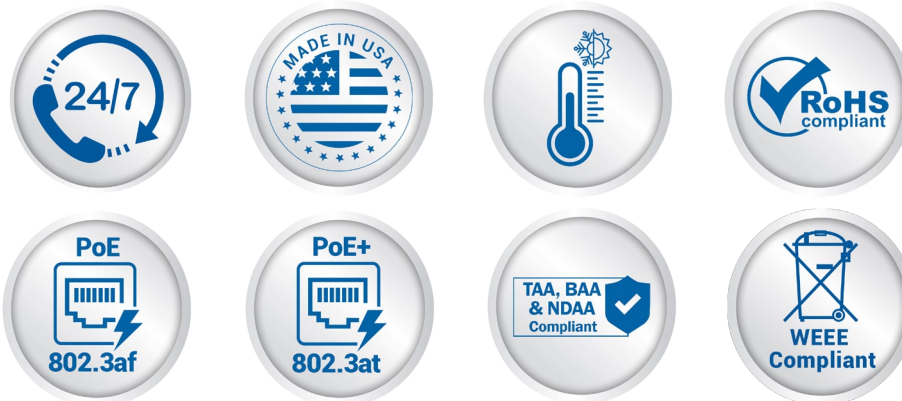
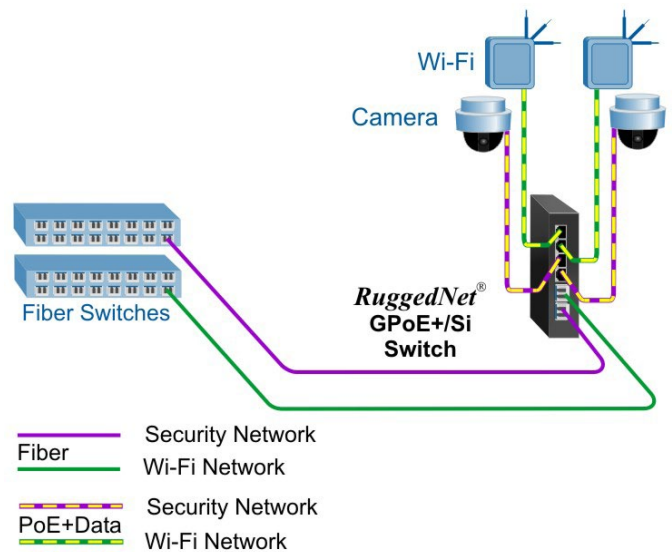

Power / Voltage Requirements and Specifications per IEEE		
Description	IEEE 802.3af PoE	IEEE 802.3at PoE+
Power Supply Voltage Range	46.0 to 57.0 VDC	51.0 to 57.0 VDC
Voltage Range at PSE port Output	44.0 to 56.0 VDC	50.0 to 56.0 VDC
Maximum Power from PoE/PSE port	15.4 watts	30 watts
Minimum Voltage at PoE/PD port input (at 100 meters using Cat5 Cable)	37.0 VDC	42.5 VDC
Minimum Power at PoE/PD port (at 100 meters using Cat5 Cable)	12.95 watts	25.5 watts

SPECIFICATIONS

Description	RuggedNet® GPoE+/Si 10/100/1000BASE-T with Fiber or Copper Uplinks Industrial Managed 6 and 10 Port PoE+ Ethernet Switch	
Standard Compliances	IEEE 802.3, IEEE 802.3af (15.40 watts), IEEE 802.3at (30 watts)	
Regulatory Compliances	<p>Safety: UL 62368-1, UL 60950-1, IEC 62368-1, IEC 60950-1, EN 62368-1, EN 60950-1, CAN/CSA C22.2 No. 62368-1-14, CAN/CSA C22.2 No. 60950-1, CE Mark, UKCA</p> <p>EMC: EN 55032/24 CE Emissions/Immunity, IEC 61000-6-4 Industrial Emissions, IEC 61000-6-2 Industrial Immunity</p> <p>EMI: CISPR 32, FCC 47 Part 15 Subpart B Class A</p> <p>EMS: IEC 61000-4-2 ESD: Contact: 6 kV; Air: 8 kV, IEC 61000-4-3 RS: 80 MHz to 1 GHz: 10 V/m (on UTP cabling) and 20 V/m (on STP cabling) IEC 61000-4-4 EFT: Power: 2 kV; Signal: 1 kV, IEC 61000-4-5 Surge: Power: 2 kV; Signal: 2 kV, IEC 61000-4-6 CS: Signal: 10 V, IEC 61000-4-8 (Magnetic Field), 30A/m, IEC 61000-4-11 (General Immunity in Industrial Environments)</p> <p>IP Rating: IP40 Protection ACT: TAA, BAA, NDAA</p>	
Environmental	REACH, RoHS and WEEE	
PoE Modes	IEEE Alternate A (Alt A)	
Frame Size	Up to 10,240 bytes	
Port Types	<p>Copper: RJ-45: 10/100/1000BASE-T</p> <p>Fiber: Fixed: ST, SC, LC 1000BASE-X Fiber SFP: 10/100/1000BASE-T SGMII Copper Transceiver or 100BASE-X SGMII Fiber Transceiver or 1000BASE-X SERDES Fiber Transceivers</p>	
Cable Types	<p>Copper: EIA/TIA 568A/B, Cat 5 UTP and higher</p> <p>Fiber: Multimode: 50/125, 62.5/125µm Single-mode: 9/125µm</p>	
DC Power Requirements	4 RJ-45 Ports: +46 to +57VDC; 2.31A @ 56VDC 2 Pin Terminal (isolated)	8 RJ-45 Ports +46 to +57VDC; 4.47A @ 56VDC 2 Pin Terminal (isolated)
Dimensions (W x D x H)	1.5" x 5.5" x 5.5" (38.1 mm x 139.7 mm x 139.7 mm)	
Weight	4 RJ-45 Ports: 1.70 lb.; 772 grams	8 RJ-45 Ports: 1.77 lb.; 803 grams
Operating Temperature	Extended: -40 to 75°C Storage: -40 to 80°C	
Humidity	5 to 95% (non-condensing)	
Altitude	-100m to 4,000m (operational)	
MTBF (hours)	278,000	
Warranty	5 year product warranty with 24/7/365 free Technical Support	

ORDERING INFORMATION

Step 1: Choose the Base Part Number (xxxx-x-xy-pZ)

Fiber Type	Distance	Connector Type					Tx / Rx Lambda (nm)	Min. Tx Power (dBm)	Max. Tx Power (dBm)	Min. Rx Power (dBm)	Max. Rx Power (dBm)	Min Atten (dB)	Link Budget (dB)
		ST	SC	LC	SFP	RJ-45							
MM/DF	220/550m ¹	9560-0-1y-pZ	9562-0-1y-pZ	9566-0-1y-pZ	-	-	850 / 850	-10	-4	-17	-3	-	7
MM/DF	2km	-	9562-6-1y-pZ	-	-	-	1310 / 1310	-9.5	-3	-19.5	-3	-	10
SM/DF	12km	9561-1-1y-pZ	9563-1-1y-pZ	9567-1-1y-pZ	-	-	1310 / 1310	-9.5	-3	-19.5	-3	-	10
SM/DF	34km	-	9563-2-1y-pZ	-	-	-	1310 / 1310	-5	0	-23	-3	3	18
SM/DF	80km	-	9563-3-1y-pZ	-	-	-	1550 / 1550	-5	0	-23	-3	3	18
SM/DF	110km	-	9563-4-1y-pZ	-	-	-	1550 / 1550	0	5	-24	-3	8	24
SM/DF	140km	-	9563-5-1y-pZ	-	-	-	1550 / 1550	2	5	-28	-8	13	30
MM/SF ²	220/550m ¹	-	9570-0-1y-pZ	-	-	-	1310 / 1550	-9	-3	-18	-3	-	9
MM/SF ²	220/550m ¹	-	9571-0-1y-pZ	-	-	-	1550 / 1310	-9	-3	-18	-3	-	9
SM/SF ²	20km	-	9570-1-1y-pZ	-	-	-	1310 / 1550	-9.5	-3	-20	-3	-	10.5
SM/SF ²	20km	-	9571-1-1y-pZ	-	-	-	1550 / 1310	-9.5	-3	-20	-3	-	10.5
SM/SF ²	40km	-	9570-2-1y-pZ	-	-	-	1310 / 1550	-3	0	-20	-3	3	17
SM/SF ²	40km	-	9571-2-1y-pZ	-	-	-	1550 / 1310	-3	0	-20	-3	3	17
SFP (x1)	-	-	-	-	9579-0-1y-pZ	-	-	-	-	-	-	-	-
SFP (x2)	-	-	-	-	9579-0-2y-pZ	-	-	-	-	-	-	-	-
RJ-45 (x2)	100m	-	-	-	-	9579-1-2y-pZ	-	-	-	-	-	-	-

¹ 62.5/125µm, 100/140µm multimode fiber up to 220m. 50/125µm multimode fiber up to 550m.

² When using single-fiber (SF) models, the Tx wavelength on one end has to match the Rx wavelength on the other.

MM = Multimode, SM = Single-mode, DF = Dual Fiber, SF = Single-fiber

Contact Omnitron for other fiber options. Order the appropriate SFPs separately. [Visit the Omnitron Optical Transceivers web page.](#)

Step 2: Choose the number of RJ-45 Ports (xxxx-x-xy-pZ)

4 = Four RJ-45 Ports
8 = Eight RJ-45 Ports

Step 3: Choose the Power Option (xxxx-x-xy-pZ)

1 = Single DC 2-Pin Terminal Power Connector
2 = Dual DC 2-Pin Terminal Power Connectors

Operating Temperature Range

Z = Extended temperature (-40 to 75°C)
--

ACCESSORIES

Model Number	Description
8260-3	Wall Mounting Plate
8260-0	19" rack mount shelf (up to 2 modules with wall mounting plate installed)

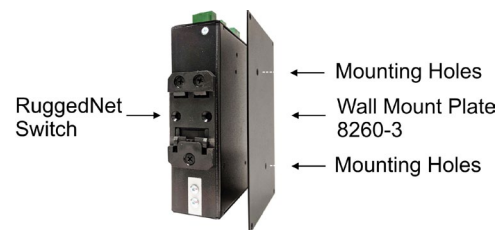

Wall Mount Plate used to wall or rack mount the RuggedNet switch

©2024 Omnitron Systems Technology, Inc. RuggedNet is a registered trademark of Omnitron Systems Technology, Inc. Trademarks are owned by their respective companies. Specifications subject to change without notice. All rights reserved.

