

RuggedNet® G/Mi

Managed Industrial 6 and 10 Port Gigabit Ethernet Switch

The RuggedNet G/Mi is a managed Industrial Ethernet switch that features fiber or copper uplink ports and four or eight 10/100/1000 RJ-45 copper user ports. The RuggedNet G/Mi enables industrial network distance extension with fiber or copper cabling.

The RuggedNet G/Mi is a standard Layer 2 Ethernet switch that forwards frames to any port based on their MAC address.

The RuggedNet G/Mi supports Directed Switch mode, which directs multicast traffic (such as video) only to the appropriate uplink port, preventing the multicast video traffic from flooding other network ports.

Models with two fiber or two copper uplink ports support redundant uplinks, industrial ring Media Redundancy Protocol (MRP), Spanning Tree protocol and daisy-chain configurations for high availability industrial network applications.

Models with two fiber or two copper uplink ports also support Dual Device mode that enables the G/Mi to operate as two independent and isolated Ethernet switches. In Dual Device mode, the G/Mi provides separate and independent data traffic paths between the two uplink ports and four or eight user ports.

The mode of operation can be configured using easily accessible DIP-switches or using Web, Telnet, SSH, SNMPv1/v2c/v3 or Serial Console management interfaces. IPv4 and IPv6 are supported on the switches. These management interfaces provide access to filtering and security options, such as, broadcast storm prevention, IGMP, IEEE 802.1x, RADIUS, TACACS+ and Access Control Lists. Email notification and alarm reporting is provided.

Models are available with fixed ST, SC, and LC fiber connectors or Small Form Pluggable (SFP) transceiver receptacles. Fiber ports support multimode or single-mode and dual fiber or single-fiber with distances up to 140km. SFP models support a variety of distances in standard, CWDM and DWDM wavelengths.

All models can be wall or rack mounted using a wall mount bracket and shelf or DIN-rail mounted using the included DIN-rail mounting clip. They are available with single or dual DC input power options.

An alarm relay is available to detect user configured events. The relay contact can be configured for normally open or normally closed operation. One alarm input is available for detecting external events such as door open or closed.



SFPs not included

KEY FEATURES

- Managed 6 and 10 Port Gigabit Ethernet Switch
- Modbus Industrial Protocol for device management and monitoring
- Supports IPv4 and IPv6
- IEEE 802.1x, RADIUS, TACACS+ and ACL
- Email Notification
- Rapid and Multiple Spanning Tree Protocol
- Media Redundancy Protocol (MRP)
- IEEE 802.1ax LAG and LACP; Act/Act and Act/Standby
- IEEE 802.1Q VLAN tagging and IEEE 802.1ad Q-in-Q
- Broadcast / Multicast / Unicast Storm Prevention
- DHCP Relay Option 82, DHCPv6 and DHCPv6 Relay
- IPv4 IGMP and IPv6 MLD snooping
- Rate Limiting, Queue prioritization and Class of Service
- IEEE 802.1ab Link Layer Discovery Protocol
- Static MAC configuration and blocking of unknown Unicast/Multicast addresses
- Management via Web, Telnet, SSH, SNMPv1/v2c/v3 and serial interfaces
- Easy to use Hierarchical Command Line Interface
- SNMP management via Omnitron's NetOutlook® management software, or third-party SNMP software
- Dual Device mode for operating as two separate switches
- Directed Switch mode prevents flooding of multicast video traffic
- Free 24/7/365 Technical Support

ADDITIONAL FEATURES

- Two 10/100/1000 copper or 100M*/1G fiber uplink ports
- Four or eight 10/100/1000 copper user ports
- ST, SC and LC fixed fiber ports or standard, CWDM or DWDM Gigabit SFP transceivers

*100Mbps supported with 100M SGMII SFP Transceivers

- Single or dual DC power for redundancy
- Alarm contacts and sensors
- Wall, Rack and DIN-rail mountable
- Fan-less design for long life
- Industrial (-40 to 75°C) operating temperature
- TAA, BAA and NDAA compliant, and Made in the USA

APPLICATIONS

Dual Device Mode Application

This Dual Device feature is extremely useful when two isolated networks domains share a single network distribution location.

The example below depicts a scenario where the Quality Control (green) network and the Manufacturing (purple) network are sharing a single distribution location. Using the two uplinks and the Dual Device mode facilitates using a single switch driving both the Quality Control and the Manufacturing devices while maintaining isolation between the networks.

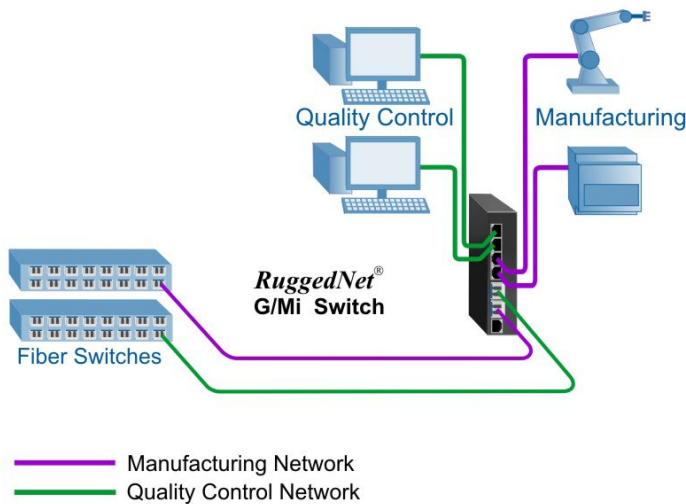

Modbus Application

Modbus is one of the oldest and most popular communication protocols used in industrial automation. Modbus-TCP is the Modbus RTU protocol with a TCP interface running on Ethernet. Omnitron's Modbus-aware switches seamlessly connect IT (Information Technology Networks) and OT (Operational Technology Networks).

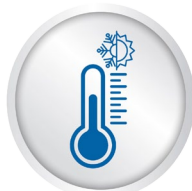
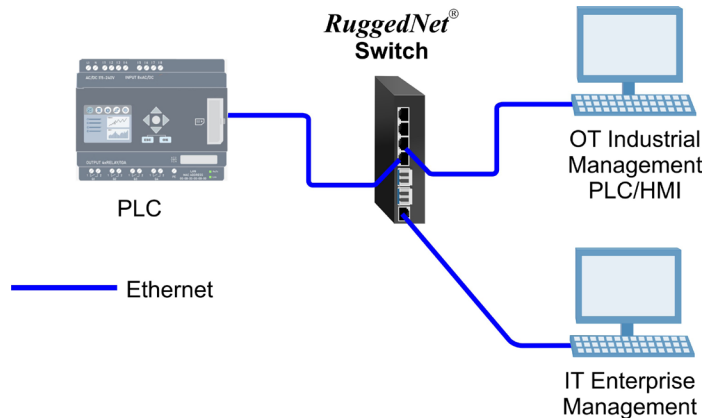

SPECIFICATIONS

Description	RuggedNet® G/Mi 10/100/1000BASE-T with Fiber or Copper Uplinks Industrial Managed 6 or 10 Port Gigabit Ethernet Switch	
Standard Compliances	IEEE 802.3, IEEE 802.1Q, IEEE 802.1ad, IEEE 802.1ab, IEEE 802.1ax, IEEE 802.1w RSTP/MSTP, RFC 5424, RFC 4541, RFC 2710, IEC 624339-2, SMTP, SNMP, RADIUS, TACACS+, IEEE 802.1	
Regulatory Compliances	<p>Safety: UL 62368-1, UL 60950-1, IEC 62368-1, IEC 60950-1, EN 62368-1, EN 60950-1, CAN/CSA C22.2 No. 62368-1-14, CAN/CSA C22.2 No. 60950-1, CE Mark, UKCA</p> <p>EMC: EN 55032/24 CE Emissions/Immunity, IEC 61000-6-4 Industrial Emissions, IEC 61000-6-2 Industrial Immunity</p> <p>EMI: CISPR 32, FCC 47 Part 15 Subpart B Class A</p> <p>EMS: IEC 61000-4-2 ESD: Contact: 6 kV; Air: 8 kV, IEC 61000-4-3 RS: 80 MHz to 1 GHz: 10 V/m (on UTP cabling) and 20 V/m (on STP cabling), IEC 61000-4-4 EFT: Power: 2 kV; Signal: 1 kV, IEC 61000-4-5 Surge: Power: 2 kV; Signal: 2 kV, IEC 61000-4-6 CS: Signal: 10 V, IEC 61000-4-8 (Magnetic Field), 30A/m, IEC 61000-4-11 (General Immunity in Industrial Environments)</p> <p>IP Rating: IP40 Protection ACT: TAA, BAA, NDAA</p>	
Environmental	REACH, RoHS and WEEE	
Management	IPv4 and IPv6 address Web, Telnet, SSH, SNMPv1/v2c/v3 In-Band management via Ethernet port Out-of-band management via serial port	
Frame Size	Up to 10,240 bytes	
Port Types	<p>Copper: RJ-45: 10/100/1000BASE-T</p> <p>Fiber: Fixed: ST, SC, LC 1000BASE-X Fiber SFP: 10/100/1000BASE-T SGMII Copper Transceiver or 100BASE-X SGMII Fiber Transceiver or 1000BASE-X SERDES Fiber Transceivers</p> <p>Serial: RJ-45 RS-232</p>	
Cable Types	<p>Copper: EIA/TIA 568A/B, Cat 5 UTP and higher</p> <p>Fiber: Multimode: 50/125, 62.5/125µm Single-mode: 9/125µm</p> <p>Serial: Category 3 and higher</p>	
DC Power Requirements	4 RJ-45 Ports: +12 to +57VDC; 0.68A @ 12VDC 0.17A @ 48VDC 2 Pin Terminal (isolated)	8 RJ-45 Ports: +12 to +57VDC; 0.75A @ 12VDC 0.19A @ 48VDC 2 Pin Terminal (isolated)
Alarm Contact (Output)	2 form C Relay for Normally Open and Normally Closed Operation 110VDC/125VAC Maximum Voltage 2A Maximum Current	
Alarm Sensor (Input)	2.0ma @ 3.3VDC Closure Detection	
Dimensions (W x D x H)	1.5" x 5.5" x 5.5" (38.1 mm x 139.7 mm x 139.7 mm)	
Weight	4 RJ-45 Ports: 1.70 lb. (772 grams)	8 RJ-45 Ports: 1.77 lb. (803 grams)
Operating Temperature	Extended: -40 to 75°C Storage: -40 to 80°C	
Humidity	5 to 95% (non-condensing)	
Altitude	-100m to 4,000m (operational)	
MTBF (hours)	282,000	
Warranty	5 year product warranty with 24/7/365 free Technical Support	

ORDERING INFORMATION

Step 1: Choose the Base Part Number (xxxx-x-xy-pZ)

Fiber Type	Distance	Connector Type					Tx/Rx Lambda (nm)	Min. Tx Power (dBm)	Max. Tx Power (dBm)	Min. Rx Power (dBm)	Max. Rx Power (dBm)	Min Atten (dB)	Link Budget (dB)
		ST	SC	LC	SFP	RJ-45							
MM/DF	220/550m ¹	2840-0-1y-pZ	2842-0-1y-pZ	2846-0-1y-pZ	-	-	850/850	-10	-4	-17	-3	-	7
MM/DF	2km	-	2842-6-1y-pZ	-	-	-	1310/1310	-9.5	-3	-19.5	-3	-	10
SM/DF	12km	2841-1-1y-pZ	2843-1-1y-pZ	2847-1-1y-pZ	-	-	1310/1310	-9.5	-3	-19.5	-3	-	10
SM/DF	34km	-	2843-2-1y-pZ	-	-	-	1310/1310	-5	0	-23	-3	3	18
SM/DF	80km	-	2843-3-1y-pZ	-	-	-	1550/1550	-5	0	-23	-3	3	18
SM/DF	110km	-	2843-4-1y-pZ	-	-	-	1550/1550	0	5	-24	-3	8	24
SM/DF	140km	-	2843-5-1y-pZ	-	-	-	1550/1550	2	5	-28	-8	13	30
MM/SF ²	220/550m ¹	-	2850-0-1y-pZ	-	-	-	1310/1550	-9	-3	-18	-3	-	9
MM/SF ²	220/550m ¹	-	2851-0-1y-pZ	-	-	-	1550/1310	-9	-3	-18	-3	-	9
SM/SF ²	20km	-	2850-1-1y-pZ	-	-	-	1310/1550	-9.5	-3	-20	-3	-	10.5
SM/SF ²	20km	-	2851-1-1y-pZ	-	-	-	1550/1310	-9.5	-3	-20	-3	-	10.5
SM/SF ²	40km	-	2850-2-1y-pZ	-	-	-	1310/1550	-3	0	-20	-3	3	17
SM/SF ²	40km	-	2851-2-1y-pZ	-	-	-	1550/1310	-3	0	-20	-3	3	17
SFP (x1)	-	-	-	-	2859-0-1y-pZ	-	-	-	-	-	-	-	-
SFP (x2)	-	-	-	-	2859-0-2y-pZ	-	-	-	-	-	-	-	-
RJ-45 (x2)	100m	-	-	-	-	2859-1-2y-pZ	-	-	-	-	-	-	-

¹ 62.5/125µm, 100/140µm multimode fiber up to 220m. 50/125µm multimode fiber up to 550m.

² When using single-fiber (SF) models, the Tx wavelength on one end has to match the Rx wavelength on the other.

MM = Multimode, SM = Single-mode, DF = Dual Fiber, SF = Single-fiber

Contact Omnitron for other fiber options. Order the appropriate SFPs separately. [Visit the Omnitron Optical Transceivers web page.](#)

Step 2: Choose the number of RJ-45 Ports (xxxx-x-xy-pZ)

4 = Four RJ-45 Ports
8 = Eight RJ-45 Ports

Step 3: Choose the Power Option (xxxx-x-xy-pZ)

1 = Single DC 2-Pin Terminal Power Connector
2 = Dual DC 2-Pin Terminal Power Connectors

Operating Temperature Range

Z = Extended temperature (-40 to 75°C)
--

ACCESSORIES

Model Number	Description
8260-3	Wall Mounting Plate
8260-0	19" rack mount shelf (up to 2 modules with wall mounting plate installed)

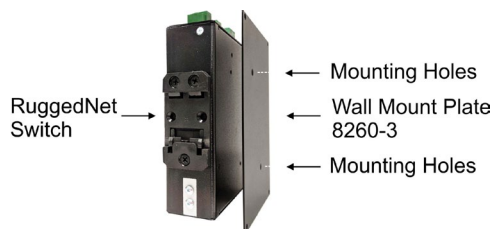

Wall Mount Plate used to wall or rack mount the RuggedNet switch

©2024 Omnitron Systems Technology, Inc. RuggedNet and NetOutlook are registered trademarks of Omnitron Systems Technology, Inc. Trademarks are owned by their respective companies. Specifications subject to change without notice. All rights reserved.

