

Omniconverter[®]
GPoE+/SE



User Manual

General and Copyright Notice

This publication is protected by U.S. and international copyright laws. All rights reserved. The whole or any part of this publication may not be reproduced, stored in a retrieval system, translated, transcribed, or transmitted, in any form, or by any means, manual, electric, electronic, electromagnetic, mechanical, chemical, optical or otherwise, without prior explicit written permission of Omnitron Systems Technology, Inc.

The following trademarks are owned by Omnitron Systems Technology, Inc.: FlexPoint[®], FlexSwitch[™], iConverter[®], miConverter[®], NetOutlook[®], OmniLight[®], OmniConverter[®], RuggedNet[®], Omnitron Systems Technology, Inc.[™], OST[™] and the Omnitron logo.

All other company or product names may be trademarks of their respective owners.

The information contained in this publication is subject to change without notice. Omnitron Systems Technology, Inc. is not responsible for any inadvertent errors.

Warranty

This product is warranted to the original purchaser (Buyer) against defects in material and workmanship for a period of two (2) years from the date of shipment. A lifetime warranty may be obtained by the original purchaser by registering this product at www.omnitron-systems.com/support within ninety (90) days from the date of shipment. During the warranty period, Omnitron will, at its option, repair or replace a product which is proven to be defective with the same product or with a product with at least the same functionality.

For warranty service, the product must be sent to an Omnitron designated facility, at Buyer's expense. Omnitron will pay the shipping charge to return the product to Buyer's designated US address using Omnitron's standard shipping method.

Limitation of Warranty

The foregoing warranty shall not apply to product malfunctions resulting from improper or inadequate use and/or maintenance of the equipment by Buyer, Buyer-supplied equipment, Buyer-supplied interfacing, unauthorized modifications or tampering with equipment (including removal of equipment cover by personnel not specifically authorized and certified by Omnitron), or misuse, or operating outside the environmental specification of the product (including but not limited to voltage, ambient temperature, radiation, unusual dust, etc.), or improper site preparation or maintenance.

No other warranty is expressed or implied. Omnitron specifically disclaims the implied warranties of merchantability and fitness for any particular purpose.

The remedies provided herein are the Buyer's sole and exclusive remedies. Omnitron shall not be liable for any direct, indirect, special, incidental, or consequential damages, whether based on contract, tort, or any legal theory.

Environmental Notices

The equipment covered by this manual must be disposed of or recycled in accordance with the Waste Electrical and Electronic Equipment Directive (WEEE Directive) of the European Community directive 2012/19/EU on waste electrical and electronic equipment (WEEE) which, together with the RoHS Directive 2015/863/EU, for electrical and electronic equipment sold in the EU after July 2019. Such disposal must follow national legislation for IT and Telecommunication equipment in accordance with the WEEE directive: (a) Do not dispose waste equipment with unsorted municipal and household waste. (b) Collect equipment waste separately. (c) Return equipment using collection method agreed with Omnitron.

The equipment is marked with the WEEE symbol shown to indicate that it must be collected separately from other types of waste. In case of small items the symbol may be printed only on the packaging or in the user manual. If you have questions regarding the correct disposal of equipment go to www.omnitron-systems.com/support or e-mail to Omnitron at intlinfo@omnitron-systems.com.



Safety Warnings and Cautions



ATTENTION: Observe precautions for handling electrostatic discharge sensitive devices.



WARNING: Potential damage to equipment and personal injury.



WARNING: Risk of electrical shock.

OmniConverter® GPoE+/SE User Manual

Product Overview

The OmniConverter GPoE+/SE are cost-effective media converters that convert 10/100/1000BASE-T copper to 1000BASE-X fiber and support Power-over-Ethernet (PoE / PoE+). They can provide up to 30W PoE+ (IEEE 802.3at) on the RJ-45 port.

The GPoE+/SE is available with one SFP transceiver receptacle uplink port or one RJ-45 uplink port and one RJ-45 PoE+ port.

The OmniConverter GPoE+/SE support frame sizes up to 10,240 bytes.

[See data sheets for available models.](#)

INSTALLATION PROCEDURE

Installation of the equipment should be such that the air flow in the front, back, side and top vents of the module is not compromised or restricted.

- 1) Install the Module
- 2) Apply Power
- 3) Connect Cables
- 4) Verify Operation

1) Installing the Module

Please contact Omnitron Systems for Conformal Coated products that can be deployed in humid environments.

Wall Mounting

The wall mounting height of the module should be less than or equal to 2 meters (6.6 feet) from the floor. Use the four mounting holes on the module to secure the module to the wall. The module can accommodate #6 screws (not included).

Installation of the module should be such that the air flow in the front, back, side and top vents of the switch are not compromised or restricted.

The accessory cables should have their own strain relief and do not pull down on the module.

Rack Mounting

The module can be rack mounted using the optional Rack Mount Shelf (8260-0). Refer to the [Rack Mount Shelf user manual \(040-08260-001x\)](#) for the proper installation guidelines.

Follow the same guidelines above when rack mounting the module.

DIN-rail Mounting

The module can be DIN-rail mounted using the optional DIN-rail Mounting Bracket (8250-0) or the optional DIN-rail Mounting Clip (8251-0). Refer to the [user manuals \(040-08250-001x or 040-08251-001x\)](#) for the proper installation guidelines.

2) Apply Power

AC Power

Secure the ground wire to the grounding screw located on the back of the module.

WARNING REGARDING EARTHING GROUND:

- It is recommended to connect the equipment to the AC power system earthing electrode conductor or to a bonding jumper from an earthing terminal bar or bus to which the AC power system earthing electrode is connected for surge protection and to eliminate damaging potentials from developing on the isolated chassis.
- There shall be no switching or disconnecting devices in the earthed circuit conductor between the AC source and the earthing electrode conductor.

To power the unit using the AC/DC adapter, route the barrel connector side of the power cord through the provided strain relief for additional support. Then connect the barrel connector at the end of the wire on the AC/DC adapter to the 2.1mm DC barrel connector (center-positive) on the unit. Connect the AC power cord on the AC/DC adapter to the AC outlet. Confirm that the module has powered up properly by checking the Power LED located on the front of the installed module.

Installation of the equipment should be such that the air flow in the front, back, side and top vents of the chassis are not compromised or restricted.

WARNING!!!

NEVER ATTEMPT TO OPEN THE CHASSIS OR SERVICE THE POWER SUPPLY. OPENING THE CHASSIS MAY CAUSE SERIOUS INJURY OR DEATH. THERE ARE NO USER REPLACEABLE OR SERVICEABLE PARTS IN THIS UNIT.

DC Power

This module is intended for installation in restricted access areas. (“Les matériels sont destinés à être installés dans des EMBLEMES À ACCÈS RESTREINT”). A restricted access area can be accessed only through the use of a special key, or other means of security.

The over current protection for connection with centralized DC shall be provided in the building installation, and shall be a UL listed circuit breaker rated 20 Amps, and installed per the National Electrical Code, ANSI/NFPA-70.

Appropriate overloading protection should be provided on the DC power source outlets utilized.

The GPoE+/SE requires 48 to 57VDC @ 0.59Amp max rated power See specification table for specific model requirements.

WARNING: Only a DC power source that complies with safety extra low voltage (SELV) requirements can be connected to the DC-input power supply.

WARNING REGARDING EARTHING GROUND:

- This equipment shall be connected to the DC supply system earthing electrode conductor or to a bonding jumper from an earthing terminal bar or bus to which the DC supply system earthing electrode is connected.
- This equipment shall be located in the same immediate area (such as adjacent cabinets) as any other equipment that has a connection between the earthed conductor of the same DC supply circuit and the earthing conductor, and also the point of earthing of the DC system. The DC system shall not be earthed elsewhere.
- The DC supply source is to be located within the same premises as this equipment.
- There shall be no switching or disconnecting devices in the earthed circuit conductor between the DC source and the earthing electrode conductor.

Locate the DC circuit breaker of the external power source, and switch the circuit breaker to the OFF position.

Prepare a power cable using a three conductor insulated wire (not supplied) with 12AWG to 14AWG thickness. Cut the power cable to the length required.

Strip approximately 3/8 of an inch of insulation from the power cable wires.

Connect the ground wire to the grounding screws on the back of the module.

Route the power cables through the provided strain relief for additional support. Connect the power cables to the module by fastening the stripped ends to the DC power connector.

WARNING: Note the wire colors used in making the positive, negative and ground connections. Use the same color assignment for the connection at the circuit breaker.

Connect the power wires to the circuit breaker and switch the circuit breaker ON. If any module are installed, the Power LED will indicate the presence of power.

During the installation, ensure that the ground potentials are maintained throughout the system connections. This includes but not limited to the power source ground and any shielded cabling grounds.

Installation of the equipment should be such that the air flow in the front, back, side and top vents of the chassis are not compromised or restricted.

WARNING!!!

NEVER ATTEMPT TO OPEN THE CHASSIS OR SERVICE THE POWER SUPPLY. OPENING THE CHASSIS MAY CAUSE SERIOUS INJURY OR DEATH. THERE ARE NO USER REPLACEABLE OR SERVICEABLE PARTS IN THIS UNIT.

3) CONNECT CABLES

- a. Insert the SFP Fiber transceiver into the SFP receptacle on the front of the module (see the SFP Data Sheet 091-17000-001 for supported Gigabit Ethernet transceivers).

NOTE: The release latch of the SFP Fiber transceiver must be in the closed (up) position before insertion.

- b. Connect the RJ-45 uplink port via an Ethernet Category 5 cable or better to an external 10/100/1000 Ethernet device.
- c. Connect the 10/100/1000 PoE RJ-45 port via an Ethernet Category 5 cable or better to an external 10/100/1000 PoE/PoE+ powered device. Non-PoE devices can be connected to the RJ-45 port.

| Description | IEEE 802.3af PoE | IEEE 802.3at PoE+ |
|---------------------------------------|------------------|-------------------|
| Power Supply Voltage Range | 46.0 to 57.0 VDC | 51.0 to 57.0 VDC |
| Voltage Range at PSE port Output | 44.0 to 56.0 VDC | 50.0 to 56.0 VDC |
| Maximum Power from PoE/PSE port | 15.4 watts | 30 watts |
| Minimum Voltage at PoE/PD port input* | 37.0 VDC | 42.5 VDC |
| Minimum Power at PoE/PD port* | 12.95 watts | 25.5 watts |

* at 100 meters using Cat5

4) VERIFY OPERATION

Once the module has been installed and configured per steps 1 - 3, verify the module is operational by viewing the LED indicators.

| Power LED Indicators | | |
|----------------------|------------|--------------------|
| Legend | Indicator | Description |
| Pwr | OFF | Module not powered |
| | Green - ON | Module powered |

| SFP Uplink Port LED Indicators | | |
|--------------------------------|--------------------------|---|
| Legend | Indicator | Description |
| 1000 | OFF | Port not linked at 1000Mbps |
| | Green - ON | Port linked at 1000Mbps Full Duplex |
| | Green - Blinking at 10Hz | Port is transmitting or receiving frames at full duplex |
| | Amber - ON | Port linked at 1000Mbps Half Duplex |
| | Amber - Blinking at 10Hz | Port is transmitting or receiving frames at half duplex |
| | Amber - Blinking at 1Hz | Port is not linked and receiving signal |

| RJ-45 Uplink Port Indicators | | |
|---------------------------------|--------------------------|---|
| Legend | Indicator | Description |
| 10 (Both 100 + 1000 LEDs) | OFF | Port not linked at 10Mbps |
| | Green - ON | Port linked at 10Mbps Full Duplex |
| | Green - Blinking at 10Hz | Port is transmitting or receiving frames at full duplex |
| | Amber - ON | Port is linked at half duplex |
| | Amber - Blinking at 10Hz | Port is transmitting or receiving frames at half duplex |
| | Amber - Blinking at 1Hz | Port not linked and receiving signal |
| 100 | OFF | Port not linked at 100Mbps |
| | Green - ON | Port linked at 100Mbps Full Duplex |
| | Green - Blinking at 10Hz | Port is transmitting or receiving frames at full duplex |
| | Amber - ON | Port is linked at half duplex |
| | Amber - Blinking at 10Hz | Port is transmitting or receiving frames at half duplex |
| | Amber - Blinking at 1Hz | Port is receiving FEFI |
| 1000 | OFF | Port not linked at 1000Mbps |
| | Green - ON | Port linked at 1000Mbps Full Duplex |
| | Green - Blinking at 10Hz | Port is transmitting or receiving frames at full duplex |
| | Amber - ON | Port is linked at half duplex |
| | Amber - Blinking at 10Hz | Port is transmitting or receiving frames at half duplex |
| | Amber - Blinking at 1Hz | Port not linked and receiving signal |

For 10M operation, both the 100 and 1000 LEDs must be ON.

| PoE RJ-45 Port Indicators | | |
|------------------------------|--------------------------|---|
| Legend | Indicator | Description |
| 10 (Both 100 + 1000 LEDs) | OFF | Port not linked at 10Mbps |
| | Green - ON | Port linked at 10Mbps Full Duplex |
| | Green - Blinking at 10Hz | Port is transmitting or receiving frames at full duplex |
| | Amber - ON | Port is linked at half duplex |
| | Amber - Blinking at 10Hz | Port is transmitting or receiving frames at half duplex |
| 100 | OFF | Port not linked at 100Mbps |
| | Green - ON | Port linked at 100Mbps Full Duplex |
| | Green - Blinking at 10Hz | Port is transmitting or receiving frames at full duplex |
| | Amber - ON | Port is linked at half duplex |
| | Amber - Blinking at 10Hz | Port is transmitting or receiving frames at half duplex |
| 1000 | OFF | Port not linked at 1000Mbps |
| | Green - ON | Port linked at 100Mbps Full Duplex |
| | Green - Blinking at 10Hz | Port is transmitting or receiving frames at full duplex |
| | Amber - ON | Port is linked at half duplex |
| | Amber - Blinking at 10Hz | Port is transmitting or receiving frames at half duplex |
| PSE | OFF | Port PSE disabled |
| | Green - ON | Port PSE is active |
| | Green - Single Blink | Powered by 802.3af PoE (4 - 15W), class 0 - 3 |
| | Green - two blinks | Powered by 802.3at PoE (30W), class 4 |
| | Amber - ON | Failed PoE negotiation |
| | Amber - Blinking at 1Hz | Cannot provide requested current |

For 10M operation, both the 100 and 1000 LEDs must be ON.

MECHANICAL

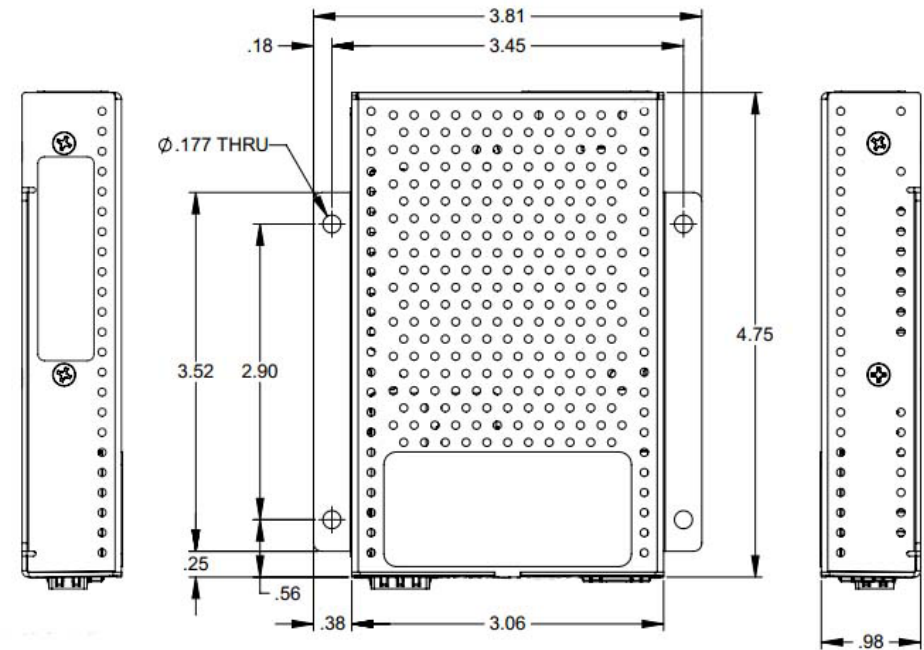

Ventilation holes may vary.

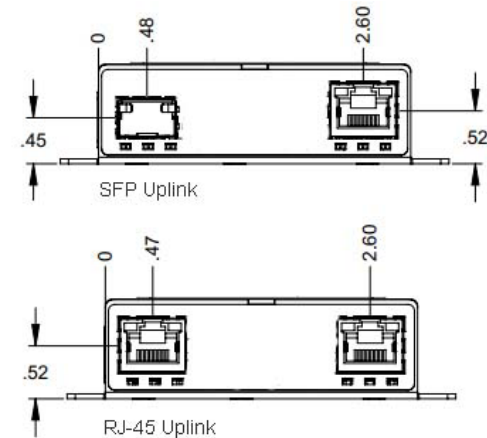

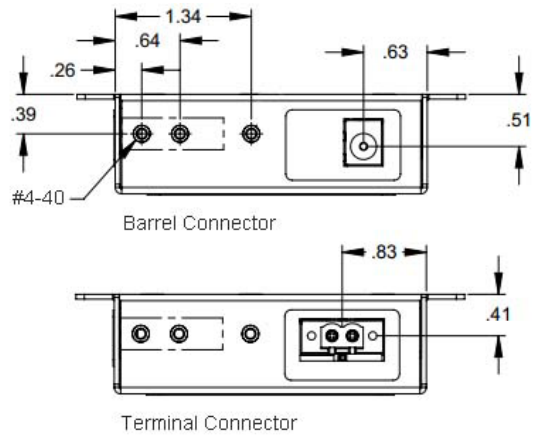

SPECIFICATIONS

| | |
|---|--|
| Standard Compliances | IEEE 802.3, IEEE 802.3af (15.40 watts max), IEEE 802.3at (30 watts max) |
| Environmental | RoHS, WEEE, REACH |
| PoE Power Modes | IEEE Alternative A (Alt A) |
| Frame Size | Up to 10,240 bytes |
| Port Types | Copper: 10/100/1000BASE-T (RJ-45) Fiber: 1000BASE-X (SFP) |
| Cable Types | Copper: EIA/TIA 568A/B, Cat 5 UTP and higher Fiber: Multimode: 50/125, 62.5/125µm Single-mode: 9/125µm |
| AC Power Requirements (Models with AC/DC Adapters) | 100 - 240VAC/50 to 60Hz 0.31A @ 120VAC (typical) |
| DC Power Requirements (Models with DC Terminals) | +/-46 to +/-57VDC; 0.59A @ 56VDC 2 Pin Terminal (isolated) |
| Dimensions (W x D x H) | 3.8" x 4.8" x 1.0" (96.5 mm x 121.9 mm x 25.4 mm) |
| Weight | Module Only: 1.0 lbs.; 453.6 grams Module w/ Adapter: 1.8 lbs.; 816.4grams |
| Operating Temperature | Commercial: 0 to 50°C Wide: -40 to 60°C (-20°C AC cold start) Storage: -40 to 80°C |
| Humidity | 5 to 95% (non-condensing) |
| Altitude | -100m to 4,000m |
| MTBF (hours) | Module Only: 681,000 AC/DC Adapter: 100,000 |
| Warranty | Lifetime warranty with 24/7/365 free Technical Support |

| | | |
|---|----------------------------------|---|
| Regulatory Compliances (Pending) | Safety: | UL 62368-1, UL 60950-1, IEC 62368-1, IEC 60950-1, CAN/CSA C22.2 No. 60950-1, EN 60950-1:2006 CE Mark, UKCA |
| | EMI: | FCC 47CFR, Part 15 Class A AS/NZS 3548, AS/NZS 4417.1 and AS/NZS 4417.2 ICES-003 Issue 3 EN 55032/CISPR 22 and EN55035 EN61000-3-2 VCCI V3/2001.04 (CISPR 22A:1997, Class A) |
| | EMS: | IEC/EN61000-4-2 IEC/EN61000-4-3; IEC/EN61000-4-4; IEC/EN61000-4-5; IEC/EN61000-4-6; IEC/EN61000-4-8; IEC/EN61000-4-11 IEC/EN61000-4-12 IEC/EN 61000-6-2 IEC/EN61000-6-4 IEC 60068-2-27 IEC 60068-2-6 |
| | IP Rating: ACT: | IP30D Protection TAA, BAA,NDAA |

Customer Support Information

If you encounter problems while installing this product, contact Omnitron Technical Support:

Phone: (949) 250-6510

Fax: (949) 250-6514

Address: Omnitron Systems Technology, Inc.

38 Tesla

Irvine, CA 92618, USA

Email: support@omnitron-systems.com

URL: www.omnitron-systems.com