

OmniConverter® GHPoE/Sx

Unmanaged 6-Port 60W Pre-IEEE 802.3bt PoE Gigabit Switches

The OmniConverter GHPoEBT/Sx replaces the GHPoE/Sx and is recommended for all new designs.

The OmniConverter GHPoE/Sx are compact unmanaged High-Power PoE Ethernet switches that feature copper or fiber uplink ports and four 10/100/1000 RJ-45 copper Power-over-Ethernet user ports.

The GHPoE/Sx is a pre-IEEE 802.3bt switch featuring up to 60W per user port models.

The OmniConverter PoE switches are standard Layer 2 Ethernet switches that forward frames to any port based on their MAC address.

All models support Directed Switch mode, which directs multicast traffic (such as video) only to the appropriate uplink port, preventing multicast traffic from flooding other network ports.

Models with two fiber or two copper uplink ports support daisy-chain configurations or redundant uplinks for critical applications that require protection and sub 50ms restoration in the event of an uplink failure.

Models with two fiber or two copper uplink ports also support Dual Device mode that enables the switches to operate as two independent and isolated Ethernet switches. In Dual Device mode, the switches provide separate and independent data traffic paths between each uplink and a pair of user ports.

The OmniConverter PoE switches are available with fixed fiber ST, SC, and LC connectors or Small Form Pluggable (SFP) transceiver receptacles. Fiber ports support multimode or single-mode and dual fiber or single-fiber with distances up to 140km. SFP models support a variety of distances in standard and CWDM and DWDM wavelengths.

The switches automatically negotiate and deliver the power level required by a Powered Device (PD) partner. Depending on the model of the OmniConverter PoE switch, the switch can deliver up to 60 Watts of power per user port.

All models feature a remote PoE power reset function that can be configured with a DIP-switch. The PoE power reset feature allows all PDs or individual PDs to be power-cycled and reset remotely to save time and expense by eliminating the need to dispatch manpower to remote network sites.

All models can be wall mounted, rack mounted using a shelf or DIN-rail mounted using DIN-rail mounting clips. They are available with an external 100 to 240V AC power adapter or with a DC terminal connector.

Not recommended for new designs



SFPs not included

KEY FEATURES

- Unmanaged High-Power 60W PoE Gigabit Ethernet Switches
- Supports 60W Pre-BT HPoE
- Two 10/100/1000 copper or Gigabit fiber uplink ports
- Four 10/100/1000 copper PoE user ports
- ST, SC and LC fixed fiber ports or standard, CWDM or DWDM Gigabit SFP transceivers
- Supports jumbo frames up to 10,240 bytes
- Configurable PoE Power Reset
- Uplink redundancy on models with two uplink ports
- Dual Device mode for operating as two separate switches
- Directed Switch mode AKA Camera mode to prevent port flooding
- Available with AC to DC power adapters or DC terminal block
- Wall, Rack and DIN-rail mountable
- Fan-less design for long life
- Commercial (0° to 50°C), wide (-40° to 60°C) and extended (-40° to 75°C) operating temperature ranges
- Made in the USA
- Free 24/7/365 Technical Support

APPLICATIONS

Dual Device Mode Application

This Dual Device feature is extremely useful when two isolated networks domains share a single network distribution location.

The example below depicts a scenario where a surveillance security (green) network and a Wi-Fi (purple) network are sharing a single hub distribution location. Using the two uplinks and the Dual Switch mode facilitates using a single PoE switch driving both the Cameras and the Wi-Fi Access Points while maintaining isolation between the networks.

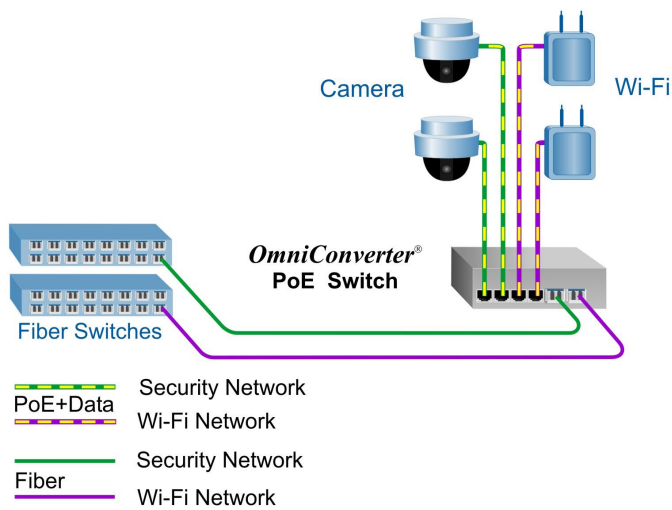

Daisy Chain Application

This example demonstrates the daisy chain capabilities of the OmniConverter PoE switches. In this application each OmniConverter switch connects to its neighboring switch via its uplink ports. The daisy chain can continue to additional switches using this method of connectivity.

Each OmniConverter switch provides connectivity to the fiber links, and 802.3bt power to IP cameras and Wi-Fi access points at each location along the daisy chain.

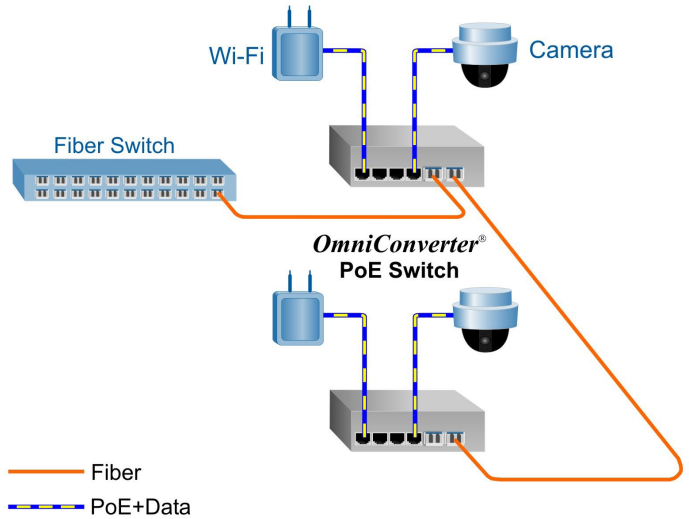

Power / Voltage Requirements and Specifications per IEEE

Description	IEEE 802.3af 15W PoE	IEEE 802.3at 30W PoE+	Pre-BT 60W PoE
Power Supply Voltage Range	46.0 to 57.0 VDC	51.0 to 57.0 VDC	51.0 to 57.0 VDC
Voltage Range at PSE port Output	44.0 to 56.0 VDC	50.0 to 56.0 VDC	50.0 to 56.0 VDC
Maximum Power from PoE/PSE port	15.4 watts	30 watts	60 watts
Minimum Voltage at PoE/PD port input*	37.0 VDC	42.5 VDC	42.5 VDC
Minimum Power at PoE/PD port*	12.95 watts	25.5 watts	51 watts
* at 100 meters using Cat5			

SPECIFICATIONS

Description	OmniConverter® GHPoE/Sx (60W Pre-BT) 10/100/1000BASE-T with Gigabit Fiber or Copper Uplinks Unmanaged 6 Port High-Power PoE Ethernet Switch
Standard Compliances	IEEE 802.3, IEEE 802.3af (15.40 watts max), IEEE 802.3at (30 watts max), High Power 60W PoE
Regulatory Compliances	<p>Safety: UL 62368-1, UL 60950-1, IEC 62368-1, IEC 60950-1, EN 62368-1, EN 60950-1, CAN/CSA C22.2 No. 62368-1-14, CAN/CSA C22.2 No. 60950-1, CE Mark</p> <p>EMC: EN 55032/24 CE Emissions/Immunity, IEC 61000-6-4 Industrial Emissions, IEC 61000-6-2 Industrial Immunity</p> <p>EMI: CISPR 32, FCC 47 Part 15 Subpart B Class A</p> <p>EMS: IEC 61000-4-2 ESD: Contact: 6 kV; Air: 8 kV, IEC 61000-4-3 RS: 80 MHz to 1 GHz: 10 V/m, IEC 61000-4-4 EFT: Power: 2 kV; Signal: 1 kV (DC models), IEC 61000-4-4 EFT: Power: 1 kV; Signal: 1 kV (AC models), IEC 61000-4-5 Surge: Power: 2 kV; Signal: 2 kV (DC models), IEC 61000-4-5 Surge: Power: 1 kV Line/Line; 2 kV Line/Gnd; Signal: 2 kV (AC models), IEC 61000-4-6 CS: Signal: 10 V, IEC 61000-4-8 (Magnetic Field) 30A/m, IEC 61000-4-11 (Voltage Dips, interrupts)</p> <p>IP Rating: IP20 Protection</p>
Environmental	REACH, RoHS and WEEE
PoE Modes	IEEE Alternate A (Alt A) 4-Pair
Frame Size	Up to 10,240 bytes
Port Types	<p>Copper: RJ-45: 10/100/1000BASE-T</p> <p>Fiber: Fixed: ST, SC, LC 1000BASE-X Fiber SFP: 10/100/1000BASE-T SGMII Copper Transceiver or 1000BASE-X Fiber Transceiver</p>
Cable Types	<p>Copper: EIA/TIA 568A/B, Cat 5 UTP and higher</p> <p>Fiber: Multimode: 50/125, 62.5/125µm Single-mode: 9/125µm</p>
AC Power Requirements (Models with AC/DC Adapters)	100 - 240VAC/50 - 60Hz 3.5A max at 115VAC 2.5A max at 230VAC
DC Power Requirements (Models with DC Terminals)	+46 to +57VDC; 4.46A @ 56VDC 2 Pin Terminal (non-isolated)
Dimensions (W x D x H)	6.28" x 5.2" x 1.5" (159.5 mm x 132.1 mm x 38.1 mm)
Weight	Module Only: 1.6 lbs.; 735 grams Module with AC/DC Adapter: 3.7 lbs.; 1703 grams
Operating Temperature (See Temperature Derating Table)	Commercial: 0 to 50°C Wide: -40 to 60°C (-20°C AC cold start) Extended: -40 to 75°C - not available for models with AC/DC Adapters Storage: -40 to 80°C
Humidity	5 to 95% (non-condensing)
Altitude	-100m to 4,000m (operational)
MTBF (hours)	Module Only: 277,000 AC/DC Adapter: 100,000
Warranty	5 year product warranty with 24/7/365 free Technical Support and 2 year AC power adapter warranty

Accessories	
Model Number	Description
8251-0	DIN-Rail Mounting Clip
8260-0	19" rack mount shelf

ORDERING INFORMATION

OmniConverter GHPoE/Sx 60W Pre-BT Models													
Fiber Type	Distance	Connector Type					Tx/Rx Lambda (nm)	Min. Tx Power (dBm)	Max. Tx Power (dBm)	Min. Rx Power (dBm)	Max. Rx Power (dBm)	Min Atten (dB)	Link Budget (dB)
		ST	SC	LC	SFP	RJ-45							
MM/DF	220/550m ¹	3000-0-14-pt	3002-0-14-pt	3006-0-14-pt	-	-	850/850	-10	-4	-17	-3	-	7
MM/DF (x2)	220/550m ¹	-	-	3006-0-24-pt	-	-	850/850	-10	-4	-17	-3	-	7
MM/DF	2km	-	3002-6-14-pt	-	-	-	1310/1310	-9.5	-3	-19.5	-3	-	10
SM/DF	12km	3001-1-14-pt	3003-1-14-pt	3007-1-14-pt	-	-	1310/1310	-9.5	-3	-19.5	-3	-	10
SM/DF (x2)	12km	-	-	3007-1-24-pt	-	-	1310/1310	-9.5	-3	-19.5	-3	-	10
SM/DF	34km	-	3003-2-14-pt	-	-	-	1310/1310	-5	0	-23	-3	3	18
SM/DF	80km	-	3003-3-14-pt	-	-	-	1550/1550	-5	0	-23	-3	3	18
SM/DF	110km	-	3003-4-14-pt	-	-	-	1550/1550	0	5	-24	-3	8	24
SM/DF	140km	-	3003-5-14-pt	-	-	-	1550/1550	2	5	-28	-8	13	30
MM/SF ²	220/550m ¹	-	3010-0-14-pt	-	-	-	1310/1550	-9	-3	-18	-3	-	9
MM/SF ²	220/550m ¹	-	3011-0-14-pt	-	-	-	1550/1310	-9	-3	-18	-3	-	9
SM/SF ²	20km	-	3010-1-14-pt	-	-	-	1310/1550	-9.5	-3	-20	-3	-	10.5
SM/SF ²	20km	-	3011-1-14-pt	-	-	-	1550/1310	-9.5	-3	-20	-3	-	10.5
SM/SF ²	40km	-	3010-2-14-pt	-	-	-	1310/1550	-3	0	-20	-3	3	17
SM/SF ²	40km	-	3011-2-14-pt	-	-	-	1550/1310	-3	0	-20	-3	3	17
SFP (x1)	-	-	-	-	3019-0-14-pt	-	-	-	-	-	-	-	-
SFP (x2)	-	-	-	-	3019-0-24-pt	-	-	-	-	-	-	-	-
RJ-45 (x2)	100m	-	-	-	-	3019-1-24-pt	-	-	-	-	-	-	-

¹ 62.5/125µm, 100/140µm multimode fiber up to 220m. 50/125µm multimode fiber up to 550m.

² When using single-fiber (SF) models, the Tx wavelength on one end has to match the Rx wavelength on the other.

MM = Multimode, SM = Single-mode, DF = Dual Fiber, SF = Single-fiber

Base Model Number: 30xx-x-x4-pt

Select the model from ordering table above.

Add the power option (p) and operating temperature range (t) to the base model number.

Power Options (p):

1 = External AC/DC Adapter, 100 - 240 VAC included, with US Power Cord

8 = External AC/DC Adapter, 100 - 240 VAC included, with Japanese Power Cord

2 = External AC/DC Adapter, 100 - 240 VAC included, No Power Cord

9 = Direct DC input, 2 pin terminal connector, no AC/DC power adapter

See AC/DC Adapter Temperature table below when ordering AC Powered models (power option 1, 2 or 8)

Operating Temperature Options (t):

<leave blank> = Commercial temperature (0 to 50°C)

W = Wide temperature (-40 to 60°C)

Z = Extended temperature (-40 to 75°C) - not available for models with AC/DC Adapters

Contact Omnitron for other fiber options. Order the appropriate SFPs separately. [Visit the Omnitron Optical Transceivers web page.](#)

AC/DC Adapter Temperature Derating Total Available Wattage to RJ-45 Ports				
Model	Watts Required	40°C	50°C	60°C
GHPoE/Sx	240 watts	Full Power	175 watts	115 watts

The AC/DC Adapter Temperature derating table is not applicable to models with DC Terminal (see Ordering table for Direct DC power option 9). The DC Terminal models will provide full PoE power over the operating temperature range of the module as long as the DC input voltage meets the requirements stated in the specification table on page 3.

See accessories on page 3.

©2021 Omnitron Systems Technology, Inc. OmniConverter and NetOutlook are registered trademarks of Omnitron Systems Technology, Inc. Trademarks are owned by their respective companies. Specifications subject to change without notice. All rights reserved.

