

### OmniConverter® G/Sx

#### Unmanaged 6 and 10 Port Gigabit Ethernet Switch

The OmniConverter G/Sx is an unmanaged compact gigabit Ethernet switch that features copper or fiber uplink ports and four or eight 10/100/1000 RJ-45 copper user ports. The OmniConverter G/Sx enables network distance extension with fiber cabling.

The OmniConverter G/Sx is a standard Layer 2 Ethernet switch that forwards network frames to any port based on their MAC address.

The OmniConverter G/Sx supports Directed Switch mode, which directs multicast traffic (such as video) only to the appropriate uplink port, preventing the multicast video traffic from flooding other network ports.

Models with two fiber or two copper uplink ports support daisy-chain configurations or redundant uplinks for critical applications that require protection and sub 50ms restoration in the event of an uplink failure.

Models with two fiber or two copper uplink ports also support Dual Device mode that enables the G/Sx to operate as two independent and isolated Ethernet switches. In Dual Device mode, the G/Sx provides separate and independent data traffic paths between the two uplink ports and four or eight user ports.

The G/Sx modes of operation can be configured using easily accessible DIP-switches. Each DIP-switch function is labeled on the side of the OmniConverter for ease of identification and use.

Models are available with fixed ST, SC, and LC fiber connectors or Small Form Pluggable (SFP) transceiver receptacles. Fiber ports support multimode or single-mode and dual fiber or single-fiber with distances up to 140 km. SFP models support a variety of distances in standard, CWDM and DWDM wavelengths.

All models can be wall mounted, rack mounted using a shelf or DIN-rail mounted using DIN-rail mounting clips. They are available with an external 100 to 240V AC power adapter or with a DC terminal connector.



SFPs not included

### KEY FEATURES

- Unmanaged 6 and 10 Port Gigabit Ethernet Switch
- Dual Device mode for operating as two separate switches
- Directed Switch mode prevents flooding of multicast video traffic
- Uplink redundancy on models with two uplink ports
- Two 10/100/1000 copper or 100M\*/1G fiber uplink ports
- Four or eight 10/100/1000 copper user ports
- ST, SC and LC fixed fiber ports or standard, CWDM or DWDM Gigabit SFP transceivers
- AC to DC Power Adapter or 2-Pin DC terminal
- Wall, Rack and DIN-rail mountable
- Fan-less design for long life
- Commercial (0° to 50°C), wide (-40° to 60°C) and extended (-40° to 75°C) operating temperature ranges
- TAA, BAA and NDAA compliant, and Made in the USA
- Free 24/7/365 Technical Support

\*100Mbps supported with 100M SGMII SFP Transceivers

# APPLICATIONS

## Dual Device Mode Application

This Dual Device feature is extremely useful when two isolated networks domains share a single network distribution location.

The example below depicts a scenario where the Administration (green) network and the Engineering (purple) network are sharing a single hub distribution location. Using the two uplinks and the Dual Switch mode facilitates using a single switch driving both the Administration and the Engineering workstations while maintaining isolation between the networks.

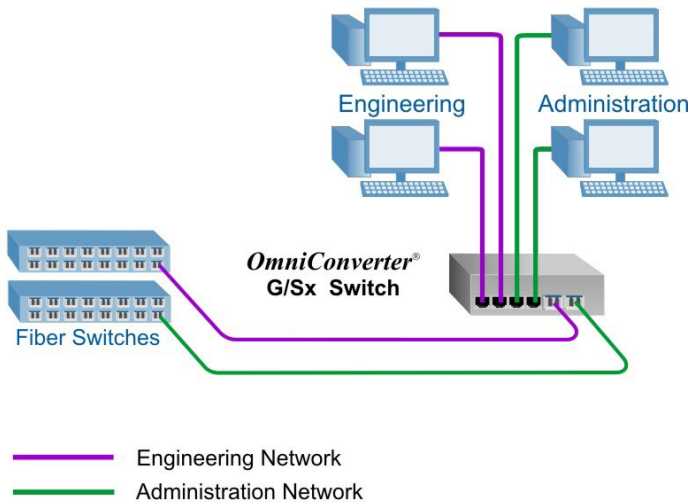

## Daisy Chain Application

This example demonstrates the daisy chain capabilities of the OmniConverter switches. In this application each OmniConverter switch connects to its neighboring switches via its uplink ports. The daisy chain can continue to additional switches using this method of connectivity.

In this application, two locations are connected using the OmniConverter switches providing connectivity between the workstations and the router.

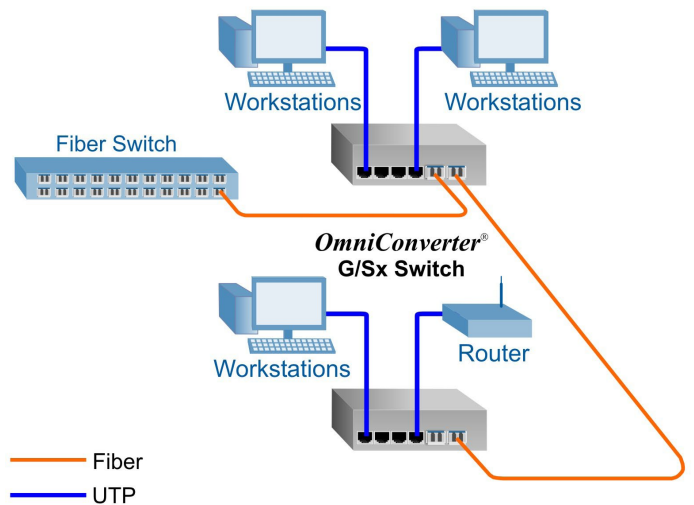

# SPECIFICATIONS

<b>Description</b>	<b>OmniConverter® G/Sx</b> 10/100/1000BASE-T with Fiber or Copper Uplinks Unmanaged 6 or 10 Port Gigabit Ethernet Switch	
<b>Standard Compliances</b>	IEEE 802.3	
<b>Regulatory Compliances</b>	<p>Safety: UL 62368-1, UL 60950-1, IEC 62368-1, IEC 60950-1, EN 62368-1, EN 60950-1, CAN/CSA C22.2 No. 62368-1-14, CAN/CSA C22.2 No. 60950-1, CE Mark, UKCA</p> <p>EMC: EN 55032/24 CE Emissions/Immunity, IEC 61000-6-4 Industrial Emissions, IEC 61000-6-2 Industrial Immunity</p> <p>EMI: CISPR 32, FCC 47 Part 15 Subpart B Class A</p> <p>EMS: IEC 61000-4-2 ESD: Contact: 6 kV; Air: 8 kV, IEC 61000-4-3 RS: 80 MHz to 1 GHz: 10 V/m, IEC 61000-4-4 EFT: Power: 2 kV; Signal: 1 kV (DC models), IEC 61000-4-4 EFT: Power: 1 kV; Signal: 1 kV (AC models), IEC 61000-4-5 Surge: Power: 2 kV; Signal: 2 kV (DC models), IEC 61000-4-5 Surge: Power: 1 kV Line/Line; 2 kV Line/Gnd; Signal: 2 kV (AC models), IEC 61000-4-6 CS: Signal: 10 V, IEC 61000-4-8 (Magnetic Field) 30A/m, IEC 61000-4-11 (Voltage Dips, interrupts)</p> <p>IP Rating: IP20 Protection ACT: TAA, BAA, NDAA</p>	
<b>Environmental</b>	REACH, RoHS and WEEE	
<b>Frame Size</b>	Up to 10,240 bytes	
<b>Port Types</b>	<p>Copper: RJ-45: 10/100/1000BASE-T</p> <p>Fiber: Fixed: ST, SC, LC 1000BASE-X Fiber SFP: 10/100/1000BASE-T SGMII Copper Transceiver or 100BASE-X SGMII Fiber Transceiver or 1000BASE-X SERDES Fiber Transceivers</p>	
<b>Cable Types</b>	<p>Copper: EIA/TIA 568A/B, Cat 5 UTP and higher</p> <p>Fiber: Multimode: 50/125, 62.5/125µm Single-mode: 9/125µm</p>	
<b>AC Power Requirements (Models with AC/DC Adapters)</b>	100 - 240VAC/50 - 60Hz 0.2A max at 115VAC; 0.1A max at 230VAC	
<b>DC Power Requirements (Models with DC Terminals)</b>	4 RJ-45 Ports: +12 to +57VDC; 0.68A @ 12VDC; 0.17A @ 48VDC 2 Pin Terminal (isolated)	8 RJ-45 Ports: +12 to +57VDC; 0.75A @ 12VDC; 0.19A @ 48VDC 2 Pin Terminal (isolated)
<b>Dimensions (W x D x H)</b>	6.28" x 5.2" x 1.5" (159.5 mm x 132.1 mm x 38.1 mm)	
<b>Weight</b>	4 RJ-45 Ports: Module Only: 1.5 lbs.; 720 grams Module with AC/DC Adapter: 2.0 lbs.; 913 grams	8 RJ-45 Ports: Module Only: 1.6 lbs.; 748 grams Module with AC/DC Adapter: 2.1 lbs.; 941 grams
<b>Operating Temperature</b>	<p>Commercial: 0 to 50°C</p> <p>Wide: -40 to 60°C (-20°C AC cold start)</p> <p>Extended: -40 to 75°C (-20°C AC cold start)</p> <p>Storage: -40 to 80°C</p>	
<b>Humidity</b>	5 to 95% (non-condensing)	
<b>Altitude</b>	-100m to 4,000m (operational)	
<b>MTBF (hours)</b>	Module Only: 309,000 AC/DC Adapter: 100,000	
<b>Warranty</b>	5 year product warranty with 24/7/365 free Technical Support and 2 year AC power adapter warranty	

# ORDERING INFORMATION

## Step 1: Choose the Base Part Number (xxxx-x-xy-pt)

OmniConverter G/Sx Models													
Fiber Type	Distance	Connector Type					Tx/Rx Lambda (nm)	Min. Tx Power (dBm)	Max. Tx Power (dBm)	Min. Rx Power (dBm)	Max. Rx Power (dBm)	Min Atten (dB)	Link Budget (dB)
		ST	SC	LC	SFP	RJ-45							
MM/DF	220/550m <sup>1</sup>	2860-0-1y-pt	2862-0-1y-pt	2866-0-1y-pt	-	-	850/850	-10	-4	-17	-3	-	7
MM/DF	2km	-	2862-6-1y-pt	-	-	-	1310/1310	-9.5	-3	-19.5	-3	-	10
SM/DF	12km	2861-1-1y-pt	2863-1-1y-pt	2867-1-1y-pt	-	-	1310/1310	-9.5	-3	-19.5	-3	-	10
SM/DF	34km	-	2863-2-1y-pt	-	-	-	1310/1310	-5	0	-23	-3	3	18
SM/DF	80km	-	2863-3-1y-pt	-	-	-	1550/1550	-5	0	-23	-3	3	18
SM/DF	110km	-	2863-4-1y-pt	-	-	-	1550/1550	0	5	-24	-3	8	24
SM/DF	140km	-	2863-5-1y-pt	-	-	-	1550/1550	2	5	-28	-8	13	30
MM/SF <sup>2</sup>	220/550m <sup>1</sup>	-	2870-0-1y-pt	-	-	-	1310/1550	-9	-3	-18	-3	-	9
MM/SF <sup>2</sup>	220/550m <sup>1</sup>	-	2871-0-1y-pt	-	-	-	1550/1310	-9	-3	-18	-3	-	9
SM/SF <sup>2</sup>	20km	-	2870-1-1y-pt	-	-	-	1310/1550	-9.5	-3	-20	-3	-	10.5
SM/SF <sup>2</sup>	20km	-	2871-1-1y-pt	-	-	-	1550/1310	-9.5	-3	-20	-3	-	10.5
SM/SF <sup>2</sup>	40km	-	2870-2-1y-pt	-	-	-	1310/1550	-3	0	-20	-3	3	17
SM/SF <sup>2</sup>	40km	-	2871-2-1y-pt	-	-	-	1550/1310	-3	0	-20	-3	3	17
SFP (x1)	-	-	-	-	2879-0-1y-pt	-	-	-	-	-	-	-	-
SFP (x2)	-	-	-	-	2879-0-2y-pt	-	-	-	-	-	-	-	-
RJ-45 (x2)	100m	-	-	-	-	2879-1-2y-pt	-	-	-	-	-	-	-

<sup>1</sup> 62.5/125µm, 100/140µm multimode fiber up to 220m. 50/125µm multimode fiber up to 550m.  
<sup>2</sup> When using single-fiber (SF) models, the Tx wavelength on one end has to match the Rx wavelength on the other.  
 MM = Multimode, SM = Single-mode, DF = Dual Fiber, SF = Single-fiber  
 Contact Omnitron for other fiber options. Order the appropriate SFPs separately. [Visit the Omnitron Optical Transceivers web page.](#)

## Step 2: Choose the number of RJ-45 Ports (xxxx-x-xy-pt)

4 = Four RJ-45 Ports
8 = Eight RJ-45 Ports

## Step 3: Choose the Power Option (xxxx-x-xy-pt)

1 = External AC/DC Adapter, 100 - 240 VAC included, with US Power Cord
2 = External AC/DC Adapter, 100 - 240 VAC included, No Power Cord
8 = External AC/DC Adapter, 100 - 240 VAC included, PS JET/PSE Certified, with Japanese Power Cord
9 = Direct DC 2 pin terminal connector, no AC/DC power adapter

## Step 4: Choose the Operating Temperature Range Option (xxxx-x-xy-pt)

<leave blank> = Commercial temperature (0 to 50°C)
W = Wide temperature (-40 to 60°C)
Z = Extended temperature (-40 to 75°C)

Accessories			
Model Number	Description	Model Number	Description
8251-0	DIN-Rail Mounting Clip	8260-0	19" rack mount shelf (up to 2 modules)

©2024 Omnitron Systems Technology, Inc. OmniConverter is a registered trademark of Omnitron Systems Technology, Inc. Trademarks are owned by their respective companies. Specifications subject to change without notice. All rights reserved.

