

### OmniConverter® G/M Managed 6 and 10 Port Gigabit Ethernet Switch

The OmniConverter G/M is a compact gigabit Ethernet switch that features fiber or copper uplink ports and four or eight 10/100/1000 RJ-45 copper user ports. The OmniConverter G/M enables network distance extension with fiber or copper cabling.

The OmniConverter G/M is a standard Layer 2 Ethernet switch that forwards frames to any port based on their MAC address.

The OmniConverter G/M supports Directed Switch mode, which directs multicast traffic (such as video) only to the appropriate uplink port, preventing the multicast video traffic from flooding other network ports.

Models with two fiber or two copper uplink ports support redundant uplinks, industrial ring Media Redundancy Protocol (MRP), Spanning Tree protocol and daisy-chain configurations for high availability industrial network applications.

Models with two fiber or two copper uplink ports also support Dual Device mode that enables the G/M to operate as two independent and isolated Ethernet switches. In Dual Device mode, the G/M provides separate and independent data traffic paths between the two uplink ports and four or eight RJ-45 user ports.

The mode of operation can be configured using easily accessible DIP-switches or using Web, Telnet, SSH, SNMPv1/v2c/v3 or Serial Console management interfaces. IPv4 and IPv6 are supported on the switches. These management interfaces provide access to filtering and security options, such as, broadcast storm prevention, IGMP, IEEE 802.1x, RADIUS, TACACS+ and Access Control Lists. Email notification and alarm reporting is provided.

Models are available with fixed ST, SC, and LC fiber connectors or Small Form Pluggable (SFP) transceiver receptacles. Fiber ports support multimode or single-mode and dual fiber or single-fiber with distances up to 140 km. SFP models support a variety of distances in standard, CWDM and DWDM wavelengths.

All models can be wall mounted, rack mounted using a shelf or DIN-rail mounted using DIN-rail mounting clips. They are available with an external 100 to 240V AC power adapter or with a DC terminal connector.



SFPs not included

### KEY FEATURES

- Managed 6 and 10 Port Gigabit Ethernet Switch
- Modbus Industrial Protocol for device management and monitoring
- Supports IPv4 and IPv6
- IEEE 802.1x, RADIUS, TACACS+ and ACL
- Email Notification
- Rapid and Multiple Spanning Tree Protocol
- Media Redundancy Protocol (MRP)
- IEEE 802.1ax LAG and LACP; Active/Active and Active/Standby
- IEEE 802.1Q VLAN tagging and IEEE 802.1ad Q-in-Q
- Broadcast / Multicast / Unicast Storm Prevention
- DHCP Relay Option 82, DHCPv6 and DHCPv6 Relay
- IPv4 Internet Group Management (IGMP) and IPv6 Multicast Listener Discovery (MLD) snooping
- Rate Limiting, Queue prioritization and Class of Service
- IEEE 802.1ab Link Layer Discovery Protocol
- Static MAC configuration and blocking of unknown Unicast/Multicast addresses
- Management via Web, Telnet, SSH, SNMPv1/v2c/v3 and serial interfaces
- Easy to use Hierarchical Command Line Interface
- SNMP management via Omnitron's NetOutlook® management software, or third-party SNMP software
- Dual Device mode for operating as two separate switches
- Directed Switch mode prevents flooding of multicast video traffic
- Free 24/7/365 Technical Support

# ADDITIONAL FEATURES

- Two 10/100/1000 copper or 100M\*/1G fiber uplink ports
- Four or eight 10/100/1000 copper user ports
- ST, SC and LC fixed fiber ports or standard, CWDM or DWDM Gigabit SFP transceivers

\*100Mbps supported with 100M SGMII SFP Transceivers

- AC to DC Power Adapter or 2-Pin DC terminal
- Wall, Rack and DIN-rail mountable
- Fan-less design for long life
- Commercial (0° to 50°C), wide (-40° to 60°C) and extended (-40° to 75°C) operating temperature ranges
- TAA, BAA and NDAA compliant, and Made in the USA

# APPLICATIONS

## Dual Device Mode Application

This Dual Device feature is extremely useful when two isolated networks domains share a single network distribution location.

The example below depicts a scenario where the Administration (green) network and the Engineering (purple) network are sharing a single distribution location. Using the two uplinks and the Dual Device mode facilitates using a single switch driving both the Administration and the Engineering workstations while maintaining isolation between the networks.

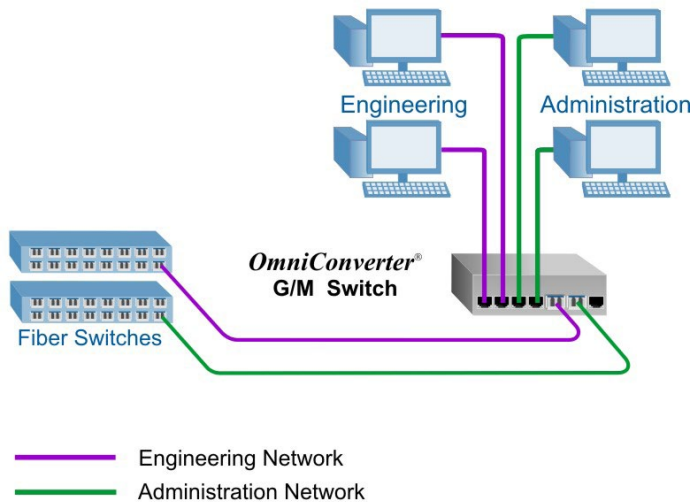

## Daisy-Chain and Ring Topology Network Application

This example demonstrates the daisy chaining and ring capabilities of the OmniConverter. In this application each OmniConverter switch connects to its neighboring switches via its uplink ports eventually closing the ring. The OmniConverter switches are providing connectivity between the workstations and the router.

Using this network architecture combined with ring protection protocols such as Media Redundancy Protocol (MRP) or Rapid Spanning Tree Protocol (RSTP) facilitates a highly resilient network required in mission critical applications.

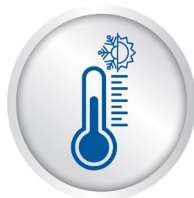
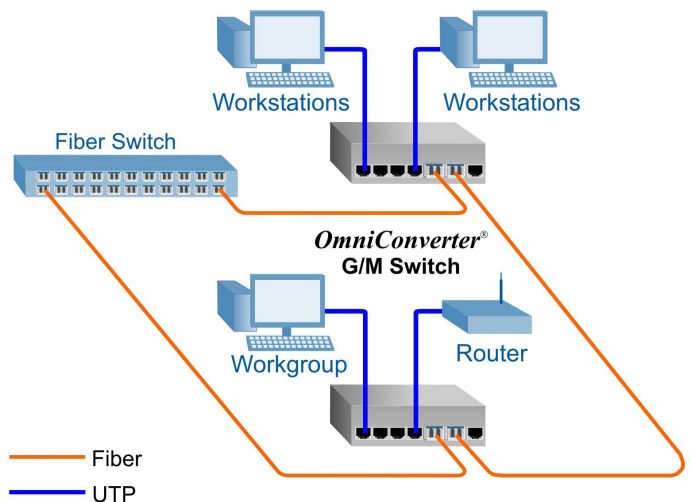

# SPECIFICATIONS

<b>Description</b>	<b>OmniConverter® G/M</b> 10/100/1000BASE-T with Fiber or Copper Uplinks Managed 6 or 10 Port Gigabit Ethernet Switch	
<b>Standard Compliances</b>	IEEE 802.3, IEEE 802.1Q, IEEE 802.1ad, IEEE 802.1ab, IEEE 802.1ax, IEEE 802.1w RSTP/MSTP, RFC 5424, RFC 4541, RFC 2710, IEC 624339-2, SMTP, SNTP, RADIUS, TACACS+, IEEE 802.1x	
<b>Regulatory Compliances</b>	<p><b>Safety:</b> UL 62368-1, UL 60950-1, IEC 62368-1, IEC 60950-1, EN 62368-1, EN 60950-1, CAN/CSA C22.2 No. 62368-1-14, CAN/CSA C22.2 No. 60950-1, CE Mark, UKCA</p> <p><b>EMC:</b> EN 55032/24 CE Emissions/Immunity, IEC 61000-6-4 Industrial Emissions, IEC 61000-6-2 Industrial Immunity</p> <p><b>EMI:</b> CISPR 32, FCC 47 Part 15 Subpart B Class A</p> <p><b>EMS:</b> IEC 61000-4-2 ESD: Contact: 6 kV; Air: 8 kV, IEC 61000-4-3 RS: 80 MHz to 1 GHz: 10 V/m, IEC 61000-4-4 EFT: Power: 2 kV; Signal: 1 kV (DC models), IEC 61000-4-4 EFT: Power: 1 kV; Signal: 1 kV (AC models), IEC 61000-4-5 Surge: Power: 2 kV; Signal: 2 kV (DC models), IEC 61000-4-5 Surge: Power: 1 kV Line/Line; 2 kV Line/Gnd; Signal: 2 kV (AC models), IEC 61000-4-6 CS: Signal: 10 V, IEC 61000-4-8 (Magnetic Field) 30A/m, IEC 61000-4-11 (Voltage Dips, interrupts)</p> <p><b>IP Rating:</b> IP20 Protection <b>ACT:</b> TAA, BAA, NDAA</p>	
<b>Environmental</b>	REACH, RoHS and WEEE	
<b>Management</b>	IPv4 and IPv6 address Web, Telnet, SSH, SNMPv1/v2c/v3 In-Band management via Ethernet port Out-of-band management via serial port	
<b>Frame Size</b>	Up to 10,240 bytes	
<b>Port Types</b>	<p><b>Copper:</b> RJ-45: 10/100/1000BASE-T</p> <p><b>Fiber:</b> Fixed: ST, SC, LC 1000BASE-X Fiber SFP: 10/100/1000BASE-T SGMII Copper Transceiver or 100BASE-X SGMII Fiber Transceiver or 1000BASE-X SERDES Fiber Transceivers</p> <p><b>Serial:</b> RJ-45: RS-232</p>	
<b>Cable Types</b>	<p><b>Copper:</b> EIA/TIA 568A/B, Cat 5 UTP and higher</p> <p><b>Fiber:</b> Multimode: 50/125, 62.5/125µm Single-mode: 9/125µm</p> <p><b>Serial:</b> Category 3 and higher</p>	
<b>AC Power Requirements (Models with AC/DC Adapters)</b>	100 - 240VAC/50 - 60Hz 0.2A max at 115VAC; 0.1A max at 230VAC	
<b>DC Power Requirements (Models with DC Terminals)</b>	4 RJ-45 Ports: +12 to +57VDC; 0.68A @ 12VDC; 0.17A @ 48VDC 2 Pin Terminal (isolated)	8 RJ-45 Ports: +12 to +57VDC; 0.75A @ 12VDC; 0.19A @ 48VDC 2 Pin Terminal (isolated)
<b>Dimensions (W x D x H)</b>	6.28" x 5.2" x 1.5" (159.5 mm x 132.1 mm x 38.1 mm)	
<b>Weight</b>	4 RJ-45 Ports: Module Only: 1.5 lb.; 720 grams Module with AC/DC Adapter: 2.0 lbs.; 913 grams	8 RJ-45 Ports: Module Only: 1.6 lbs.; 748 grams Module with AC/DC Adapter: 2.1 lbs.; 941 grams
<b>Operating Temperature</b>	<p><b>Commercial:</b> 0 to 50°C</p> <p><b>Wide:</b> -40 to 60°C (-20°C AC cold start)</p> <p><b>Extended:</b> -40 to 75°C (-20°C AC cold start)</p> <p><b>Storage:</b> -40 to 80°C</p>	
<b>Humidity</b>	5 to 95% (non-condensing)	
<b>Altitude</b>	-100m to 4,000m (operational)	
<b>MTBF (hours)</b>	Module Only: 289,000 AC/DC Adapter: 100,000	
<b>Warranty</b>	5 year product warranty with 24/7/365 free Technical Support and 2 year AC power adapter warranty	

# ORDERING INFORMATION

## Step 1: Choose the Base Part Number (xxxx-x-xy-pt)

OmniConverter G/M Models													
Fiber Type	Distance	Connector Type					Tx/Rx Lambda (nm)	Min. Tx Power (dBm)	Max. Tx Power (dBm)	Min. Rx Power (dBm)	Max. Rx Power (dBm)	Min Atten (dB)	Link Budget (dB)
		ST	SC	LC	SFP	RJ-45							
MM/DF	220/550m <sup>1</sup>	2820-0-1y-pt	2822-0-1y-pt	2826-0-1y-pt	-	-	850/850	-10	-4	-17	-3	-	7
MM/DF	2km	-	2822-6-1y-pt	-	-	-	1310/1310	-9.5	-3	-19.5	-3	-	10
SM/DF	12km	2821-1-1y-pt	2823-1-1y-pt	2827-1-1y-pt	-	-	1310/1310	-9.5	-3	-19.5	-3	-	10
SM/DF	34km	-	2823-2-1y-pt	-	-	-	1310/1310	-5	0	-23	-3	3	18
SM/DF	80km	-	2823-3-1y-pt	-	-	-	1550/1550	-5	0	-23	-3	3	18
SM/DF	110km	-	2823-4-1y-pt	-	-	-	1550/1550	0	5	-24	-3	8	24
SM/DF	140km	-	2823-5-1y-pt	-	-	-	1550/1550	2	5	-28	-8	13	30
MM/SF <sup>2</sup>	220/550m <sup>1</sup>	-	2830-0-1y-pt	-	-	-	1310/1550	-9	-3	-18	-3	-	9
MM/SF <sup>2</sup>	220/550m <sup>1</sup>	-	2831-0-1y-pt	-	-	-	1550/1310	-9	-3	-18	-3	-	9
SM/SF <sup>2</sup>	20km	-	2830-1-1y-pt	-	-	-	1310/1550	-9.5	-3	-20	-3	-	10.5
SM/SF <sup>2</sup>	20km	-	2831-1-1y-pt	-	-	-	1550/1310	-9.5	-3	-20	-3	-	10.5
SM/SF <sup>2</sup>	40km	-	2830-2-1y-pt	-	-	-	1310/1550	-3	0	-20	-3	3	17
SM/SF <sup>2</sup>	40km	-	2831-2-1y-pt	-	-	-	1550/1310	-3	0	-20	-3	3	17
SFP (x1)	-	-	-	-	2839-0-1y-pt	-	-	-	-	-	-	-	-
SFP (x2)	-	-	-	-	2839-0-2y-pt	-	-	-	-	-	-	-	-
RJ-45 (x2)	100m	-	-	-	-	2839-1-2y-pt	-	-	-	-	-	-	-

<sup>1</sup> 62.5/125µm, 100/140µm multimode fiber up to 220m. 50/125µm multimode fiber up to 550m.  
<sup>2</sup> When using single-fiber (SF) models, the Tx wavelength on one end has to match the Rx wavelength on the other.  
 MM = Multimode, SM = Single-mode, DF = Dual Fiber, SF = Single-fiber  
 Contact Omnitron for other fiber options. Order the appropriate SFPs separately. [Visit the Omnitron Optical Transceivers web page.](#)

## Step 2: Choose the number of RJ-45 Ports (xxxx-x-xy-pt)

4 = Four RJ-45 Ports
8 = Eight RJ-45 Ports

## Step 3: Choose the Power Option (xxxx-x-xy-pt)

1 = External AC/DC Adapter, 100 - 240 VAC included, with US Power Cord
2 = External AC/DC Adapter, 100 - 240 VAC included, No Power Cord
8 = External AC/DC Adapter, 100 - 240 VAC included, PS JET/PSE Certified, with Japanese Power Cord
9 = Direct DC 2 pin terminal connector, no AC/DC power adapter

## Step 4: Choose the Operating Temperature Range Option (xxxx-x-xy-pt)

<leave blank> = Commercial temperature (0 to 50°C)
W = Wide temperature (-40 to 60°C)
Z = Extended temperature (-40 to 75°C)

Accessories			
Model Number	Description	Model Number	Description
8251-0	DIN-Rail Mounting Clip	8260-0	19" rack mount shelf (up to 2 modules)

©2024 Omnitron Systems Technology, Inc. OmniConverter and NetOutlook are registered trademarks of Omnitron Systems Technology, Inc. Trademarks are owned by their respective companies. Specifications subject to change without notice. All rights reserved.

