

Omniconverter[®]
FPoE+/S



User Manual

General and Copyright Notice

This publication is protected by U.S. and international copyright laws. All rights reserved. The whole or any part of this publication may not be reproduced, stored in a retrieval system, translated, transcribed, or transmitted, in any form, or by any means, manual, electric, electronic, electromagnetic, mechanical, chemical, optical or otherwise, without prior explicit written permission of Omnitron Systems Technology, Inc.

The following trademarks are owned by Omnitron Systems Technology, Inc.: FlexPoint[®], FlexSwitch[™], iConverter[®], miConverter[®], NetOutlook[®], OmniLight[®], OmniConverter[®], RuggedNet[®], Omnitron Systems Technology, Inc.[™], OST[™] and the Omnitron logo.

All other company or product names may be trademarks of their respective owners.

The information contained in this publication is subject to change without notice. Omnitron Systems Technology, Inc. is not responsible for any inadvertent errors.

Warranty

This product is warranted to the original purchaser (Buyer) against defects in material and workmanship for a period of two (2) years from the date of shipment. A lifetime warranty may be obtained by the original purchaser by registering this product at www.omnitron-systems.com/support within ninety (90) days from the date of shipment. During the warranty period, Omnitron will, at its option, repair or replace a product which is proven to be defective with the same product or with a product with at least the same functionality.

For warranty service, the product must be sent to an Omnitron designated facility, at Buyer's expense. Omnitron will pay the shipping charge to return the product to Buyer's designated US address using Omnitron's standard shipping method.

Limitation of Warranty

The foregoing warranty shall not apply to product malfunctions resulting from improper or inadequate use and/or maintenance of the equipment by Buyer, Buyer-supplied equipment, Buyer-supplied interfacing, unauthorized modifications or tampering with equipment (including removal of equipment cover by personnel not specifically authorized and certified by Omnitron), or misuse, or operating outside the environmental specification of the product (including but not limited to voltage, ambient temperature, radiation, unusual dust, etc.), or improper site preparation or maintenance.

No other warranty is expressed or implied. Omnitron specifically disclaims the implied warranties of merchantability and fitness for any particular purpose.

The remedies provided herein are the Buyer's sole and exclusive remedies. Omnitron shall not be liable for any direct, indirect, special, incidental, or consequential damages, whether based on contract, tort, or any legal theory.

Environmental Notices

The equipment covered by this manual must be disposed of or recycled in accordance with the Waste Electrical and Electronic Equipment Directive (WEEE Directive) of the European Community directive 2012/19/EU on waste electrical and electronic equipment (WEEE) which, together with the RoHS Directive 2015/863/EU, for electrical and electronic equipment sold in the EU after July 2019. Such disposal must follow national legislation for IT and Telecommunication equipment in accordance with the WEEE directive: (a) Do not dispose waste equipment with unsorted municipal and household waste. (b) Collect equipment waste separately. (c) Return equipment using collection method agreed with Omnitron.

The equipment is marked with the WEEE symbol shown to indicate that it must be collected separately from other types of waste. In case of small items the symbol may be printed only on the packaging or in the user manual. If you have questions regarding the correct disposal of equipment go to www.omnitron-systems.com/support or e-mail to Omnitron at intlinfo@omnitron-systems.com.



Safety Warnings and Cautions



ATTENTION: Observe precautions for handling electrostatic discharge sensitive devices.



WARNING: Potential damage to equipment and personal injury.



WARNING: Risk of electrical shock.

OmniConverter FPoE+/S User Manual

Product Overview

The OmniConverter FPoE+/S are multi-port IEEE 802.3at PoE+ Ethernet media converters that feature one or two fiber uplink ports, one or two copper uplink ports and one or two 10/100 RJ-45 PoE+ ports.

[See data sheet for available models.](#)

The OmniConverter FPoE+/S provides up to 30W PoE+ (IEEE 802.3at) per RJ-45 port and supports frame sizes up to 10,240 bytes.

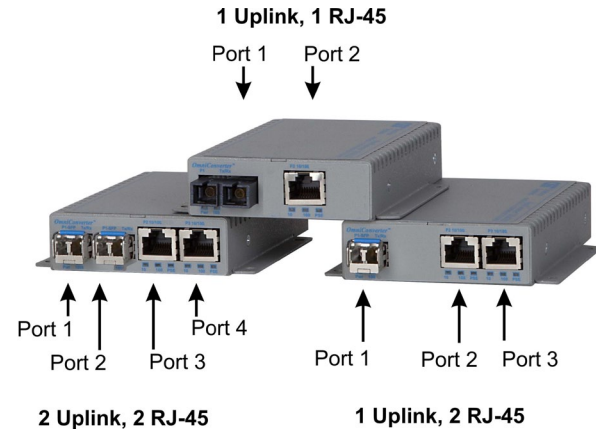

Installation Procedure

- 1) Configure DIP-switches
- 2) Installing the Module
- 3) Apply Power
- 4) Connect Cables
- 5) Verify Operation

1) Configure DIP-switches

DIP-switches are located on the side of the module. The DIP-switches are used to configure ports, link modes and PoE/PSE options.

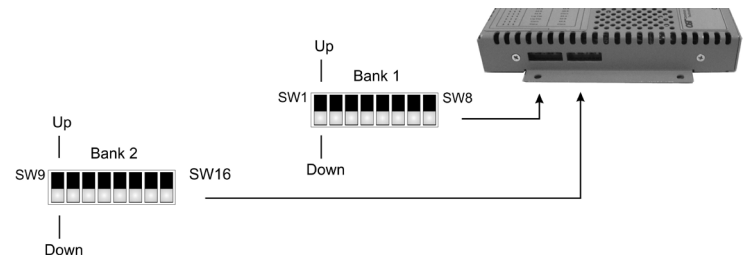

The table below provides a description of each DIP-switch position and function for Dual Uplink Ports.

Switch	Position	Function			
		2 SFP + 2 PoE+ RJ-45	2 RJ-45 + 2 PoE+ RJ-45	2 SFP + 1 PoE+ RJ-45	2 RJ-45 + 1 PoE+ RJ-45
1	DOWN	Mode of Operation			
	UP				
2	DOWN				
	UP				
3	DOWN	P1/P2 Auto	P1/P2 AN 100M FDX	P1/P2 Auto	P1/P2 AN 100M FDX
	UP	P1/P2 100M	P1/P2 10M FDX	P1/P2 100M	P1/P2 10M FDX
4	DOWN	P3 AN 100M FDX			
	UP	P3 10M FDX			
5	DOWN	P4 AN 100M FDX		Reserved	Reserved
	UP	P4 10M FDX			
6	DOWN	Reserved	Reserved	Reserved	Reserved
	UP				
7	DOWN				
	UP				
8	DOWN				
	UP				
9	DOWN				
	UP				
10	DOWN	P3 PoE Reset Disable			
	UP	P3 PoE Reset Enable			
11	DOWN	P4 PoE Reset Disable		Reserved	Reserved
	UP	P4 PoE Reset Enable			
12	DOWN	Pause Disabled			
	UP	Pause Enabled			
13	DOWN	Link Modes			
	UP				
14	DOWN				
	UP				
15	DOWN	Reserved			
	UP				
16	DOWN				
	UP				

The table below provides a description of each DIP-switch position and function for Single Uplink Ports.

Switch	Position	Function			
		1 SFP or FF + 2 PoE+ RJ-45	1 RJ-45 + 2 PoE+ RJ-45	1 SFP or FF + 1 PoE+ RJ-45	1 RJ-45 + 1 PoE+ RJ-45
1	DOWN	Mode of Operation		Reserved	
	UP				
2	DOWN			Reserved	
	UP				
3	DOWN	P1/P2 SFP Auto	P1 AN 100M FDX	P1/P2 SFP Auto	P1 AN 100M FDX
	UP	P1/P2 SFP 100M	P1 10M FDX	P1/P2 SFP 100M	P1 10M FDX
4	DOWN	P2 AN 100M FDX			
	UP	P2 10M FDX			
5	DOWN	P3 AN 100M FDX		Reserved	Reserved
	UP	P3 10M FDX			
6	DOWN	Reserved	Reserved	Reserved	Reserved
	UP				
7	DOWN				
	UP				
8	DOWN				
	UP				
9	DOWN				
	UP				
10	DOWN	P2 PoE Reset Disable			
	UP	P2 PoE Reset Enable			
11	DOWN	P3 PoE Reset Disable		Reserved	Reserved
	UP	P3 PoE Reset Enable			
12	DOWN	Pause Disabled			
	UP	Pause Enabled			
13	DOWN	Link Modes			
	UP				
14	DOWN				
	UP				
15	DOWN	Reserved			
	UP				
16	DOWN				
	UP				

The fixed fiber P1 port operates at 100M only.

SW1 and SW2: Mode Of Operation

The modules support different modes based on the port configuration. See table below.

SW1	SW2	Function			
		2 Uplink Ports + 2 PoE RJ-45 Ports	2 Uplink Ports + 1 PoE RJ-45 Ports	1 Uplink Ports + 2 PoE RJ-45 Ports	1 Uplink Ports + 1 PoE RJ-45 Ports
DOWN	DOWN	Normal	Normal	Normal	Normal
DOWN	UP	Directed Switch	Directed Switch	Directed Switch	Reserved
UP	DOWN	Protected	Protected	Reserved	Reserved
UP	UP	Dual Device	Reserved	Reserved	Reserved

Normal Switch Mode

When these DIP-switch is in the factory default DOWN “Normal” position, the module is configured for Switch Mode. In this mode, the module operates as a standard layer 2 switch. Data flow will follow MAC address mapping.

Directed Switch (AKA Camera Mode)

When SW1 is in the DOWN position and SW2 is in the UP position, the module is configured for Directed Switch Mode. In this mode, traffic from all the RJ-45 PoE+ ports is only forwarded to the Uplink Port P1, preventing broadcast traffic from flooding the other network ports. Incoming traffic from Uplink Port P1 follows MAC address mapping. For models with two Uplink Ports (copper or fiber), the data traffic on the additional Uplink Port P2 is also forwarded to Uplink Port P1.

The diagrams below depict the operation of the module with SFP uplink ports. Models with RJ-45 uplink ports operate in the same manner as shown below.

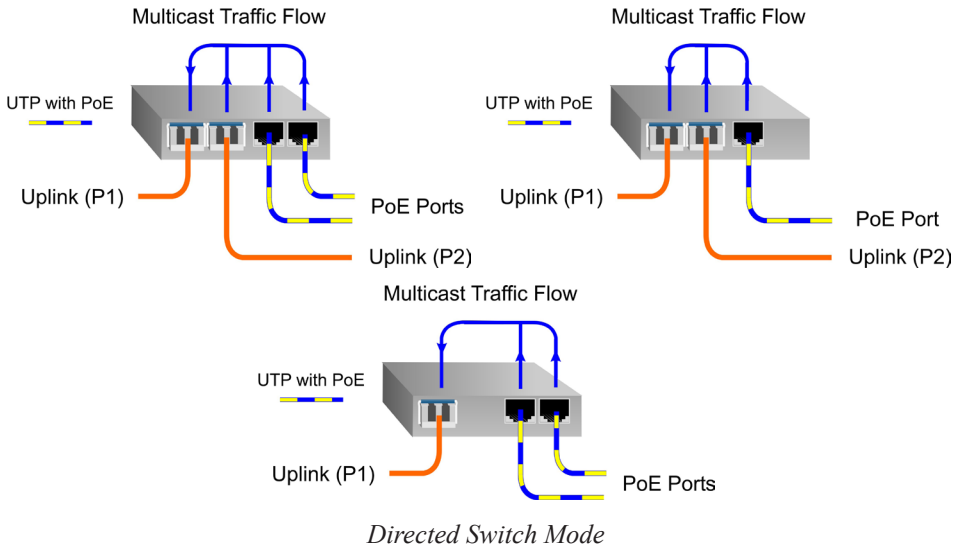

Protected

Protected mode is only available on models with two uplink ports.

When SW1 is in the UP position and SW2 is in the DOWN position, the module is configured for Protected mode.

When configured for Protected Mode, the uplink ports operate as redundant links. A fault on the primary Uplink Port P1 will cause a fail over to the secondary Uplink Port P2. The module will return to the primary Uplink Port P1 after the failure condition has been restored for 5 seconds.

The diagrams below depict the operation of the module with SFP uplink ports. Models with RJ-45 uplink ports operate in the same manner as shown below.

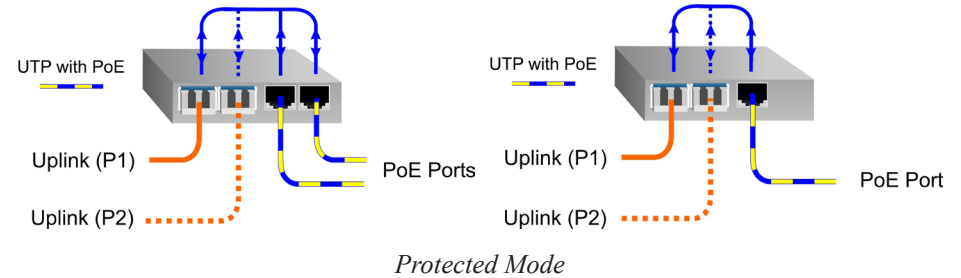

Dual Device

Dual Device mode is only supported on models with two uplink ports and two PoE RJ-45 ports.

When configured for Dual Device Mode, the module is configured as two logically independent Layer 2 switches. Uplink Port P1 is associated with P3 PoE RJ-45 port and Uplink Port P2 is associated with P4 PoE RJ-45 port. Data flow will follow MAC address mapping.

The diagrams below depict the operation of the module with SFP uplink ports. Models with RJ-45 uplink ports operate in the same manner as shown below.

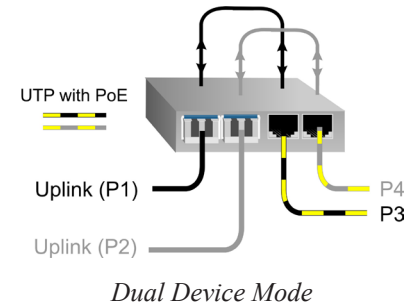

SW3

Switch SW3 configures the speed of the Uplink port. For SFP models, the module will determine the speed of the installed SFP based on the MSA compliant speed/rate identifier (DOWN). If the module can not determine the speed or recognize the installed transceiver, the speed must be configured per SW3 (UP).

Switch	Position	2 SFP Ports	2 RJ-45 Ports	1 SFP Port	1 RJ-45 Port	1 FF Port
SW3	DOWN	P1/P2 Auto	P1/P2 AN	P1 Auto	P1 AN	-
	UP	P1/P2 100M	P1/P2 MAN 10M FDX	P1 100M	P1 MAN 10M FDX	-

SW4 and SW5

These switches configure the negotiation mode of the PoE+ RJ-45 ports. If the port is configured for auto-negotiation, the speed and duplex DIP-switches are ignored. See table below.

Switch	Position	2 Uplink Ports + 2 PoE+ RJ-45 Ports	2 Uplink Ports + 1 PoE+ RJ-45 Port	1 Uplink Ports + 2 PoE+ RJ-45 Ports	1 Uplink Port + 1 PoE+ RJ-45 Port
SW4	DOWN	P3 Auto	P3 Auto	P2 Auto	P2 Auto
	UP	P3 Manual 10M FDX	P3 Manual 10M FDX	P2 Manual 10M FDX	P2 Manual 10M FDX
SW5	DOWN	P4 Auto	-	P3 Auto	-
	UP	P4 Manual 10M FDX	-	P3 Manual 10M FDX	-

SW6, SW7, SW8 and SW9

These DIP-switch are for future use and must be left in the factory default DOWN position.

SW10 and SW11

The module can be configured to disable (reset) the PoE output power for 5 seconds after a loss of receive link on any uplink port. This feature is typically used to allow a PD to re-initialize after a failure on the incoming fiber. When the DIP-switches are in the UP position, the module will disable PoE output power for 5 seconds following a loss of receive link on any uplink port. When the DIP-switches are in the DOWN position, PoE output power does not reset on a loss of connection on the uplink port.

See table below for detailed DIP-switch settings.

Switch	Position	2 Uplink Ports + 2 PoE+ RJ-45 Ports	2 Uplink Ports + 1 PoE+ RJ-45 Port	1 Uplink Ports + 2 PoE+ RJ-45 Ports	1 Uplink Port + 1 PoE+ RJ-45 Port
SW10	DOWN	P3 PoE Reset Disabled	P3 PoE Reset Disabled	P2 PoE Reset Disabled	P2 PoE Reset Disabled
	UP	P3 PoE Reset Enabled	P3 PoE Reset Enabled	P2 PoE Reset Enabled	P2 PoE Reset Enabled
SW11	DOWN	P4 PoE Reset Disabled	-	P3 PoE Reset Disabled	-
	UP	P4 PoE Reset Enabled	-	P3 PoE Reset Enabled	-

SW12

When this DIP-switch is in the DOWN (Pause disabled), no Pause capability is advertised.

When a port is in auto-negotiation mode, setting this DIP-switch to the UP position (Pause enabled) allows the unit to advertise Symmetrical and Asymmetrical Receive Pause capability.

When a port is in manual mode, setting this DIP-switch to the UP position (Pause enabled) determines the port's Symmetrical Pause behavior.

SW13 and SW14

The module supports Link Segment and Asymmetrical Link Propagate.

SW12	SW13	Function
DOWN	DOWN	Link Segment (LS)
UP	DOWN	Asymmetrical Link Propagate (Uplink Port to PoE Port) Port 1 to Port 2 (1+1 - 2 Port models), Port 1 to Port 2 and Port 3 (1+2 - 3 Port models), Port 1 and Port 2 to Port 3 (2+1 - 3 Port models), Port 1 and Port 2 to Port 3 and Port 4 (2+2 - 4 Port models).
DOWN	UP	Asymmetrical Link Propagate (PoE Port to Uplink Port) Port 2 to Port 1 (1+1 - 2 Port models), Port 2 and Port 3 to Port 1 (1+2 - 3 Port models), Port 3 to Port 1 and Port 2 (2+1 - 3 Port models), Port 3 and Port 4 to Port 1 and Port 2 (2+2 - 4 Port models)
UP	UP	Invalid Configuration

Link Segment

In Link Segment mode, all ports operate independently. A loss of a receive link signal will only affect the port detecting the loss of signal. All the other ports will continue to generate a link signal. A loss of link on the RJ-45 port will only affect the RJ-45 port, and the other ports will remain unaffected.

Asymmetrical Link Propagate

In Asymmetrical Link Propagate mode, faults are propagated based on the port notation. Port 1 to Port 2 notation indicates the direction the loss of link signal will propagate. A loss of receive link on the uplink Port 1 causes the RJ-45 Port 2 to drop its link due to the propagated state (Port 1 to Port 2). The loss of link on the RJ-45 Port 2 does not cause the loss of link to propagate. The loss only propagates in the Port 1 to Port 2 direction.

Note: A loss of link or loss of signal is when the uplink port or RJ-45 port can no longer detect the presence of a signal.

Note: On models with 2 uplink ports or 2 RJ-45 ports, both ports of the same media type must be in link fault condition before the fault will propagate.

SW15 and SW16

These DIP-switch are for future use and must be left in the factory default DOWN position.

2) Installing the Module

Please contact Omnitron Systems for Conformal Coated products that can be deployed in humid environments.

Wall Mounting

The wall mounting height of the module should be less than or equal to 2 meters (6.6 feet) from the floor. Use the four mounting holes on the module to secure the module to the wall. The module can accommodate #6 screws (not included).

Installation of the module should be such that the air flow in the front, back, side and top vents of the switch are not compromised or restricted.

The accessory cables should have their own strain relief and do not pull down on the module.

Rack Mounting

The module can be rack mounted using the optional Rack Mount Shelf (8260-0). Refer to the [Rack Mount Shelf user manual \(040-08260-001x\)](#) for the proper installation guidelines.

Follow the same guidelines above when rack mounting the module.

DIN-rail Mounting

The module can be DIN-rail mounted using the optional DIN-rail Mounting Bracket (8250-0) or the optional DIN-rail Mounting Clip (8251-0). Refer to the [user manuals \(040-08250-001x or 040-08251-001x\)](#) for the proper installation guidelines.

3) Apply Power

AC Power

Secure the ground wire to the grounding screw located on the back of the module.

WARNING REGARDING EARTHING GROUND:

- It is recommended to connect the equipment to the AC power system earthing electrode conductor or to a bonding jumper from an earthing terminal bar or bus to which the AC power system earthing electrode is connected for surge protection and to eliminate damaging potentials from developing on the isolated chassis.
- There shall be no switching or disconnecting devices in the earthed circuit conductor between the AC source and the earthing electrode conductor.

To power the unit using the AC/DC adapter, route the barrel connector side of the power cord through the provided strain relief for additional support. Then connect the barrel connector at the end of the wire on the AC/DC adapter to the 2.1mm DC barrel connector (center-positive) on the unit. Connect the AC power cord on the

AC/DC adapter to the AC outlet. Confirm that the module has powered up properly by checking the Power LED located on the front of the installed module.

Installation of the equipment should be such that the air flow in the front, back, side and top vents of the chassis are not compromised or restricted.

WARNING!!!

NEVER ATTEMPT TO OPEN THE CHASSIS OR SERVICE THE POWER SUPPLY. OPENING THE CHASSIS MAY CAUSE SERIOUS INJURY OR DEATH. THERE ARE NO USER REPLACEABLE OR SERVICEABLE PARTS IN THIS UNIT.

DC Power

This module is intended for installation in restricted access areas. ("Les matériels sont destinés à être installés dans des EMBLEMES À ACCÈS RESTREINT"). A restricted access area can be accessed only through the use of a special key, or other means of security.

The over current protection for connection with centralized DC shall be provided in the building installation, and shall be a UL listed circuit breaker rated 20 Amps, and installed per the National Electrical Code, ANSI/NFPA-70.

Appropriate overloading protection should be provided on the DC power source outlets utilized.

The one PoE+ RJ-45 FPoE+/S requires 0.78A @ 46VDC (46 to 57VDC). The two PoE+ RJ-45 FPoE+/S requires 1.45A @ 46VDC (46 to 57VDC). See specification table for specific model requirements.

WARNING: Only a DC power source that complies with safety extra low voltage (SELV) requirements can be connected to the DC-input power supply.

WARNING REGARDING EARTHING GROUND:

- This equipment shall be connected to the DC supply system earthing electrode conductor or to a bonding jumper from an earthing terminal bar or bus to which the DC supply system earthing electrode is connected.
- This equipment shall be located in the same immediate area (such as adjacent cabinets) as any other equipment that has a connection between the earthed conductor of the same DC supply circuit and the earthing conductor, and also the point of earthing of the DC system. The DC system shall not be earthed elsewhere.
- The DC supply source is to be located within the same premises as this equipment.
- There shall be no switching or disconnecting devices in the earthed circuit conductor between the DC source and the earthing electrode conductor.

Locate the DC circuit breaker of the external power source, and switch the circuit breaker to the OFF position.

Prepare a power cable using a three conductor insulated wire (not supplied) with 12AWG to 14AWG thickness. Cut the power cable to the length required.

Strip approximately 3/8 of an inch of insulation from the power cable wires.

Connect the ground wire to the grounding screws on the back of the module.

Route the power cables through the provided strain relief for additional support. Connect the power cables to the module by fastening the stripped ends to the DC power connector.

WARNING: Note the wire colors used in making the positive, negative and ground connections. Use the same color assignment for the connection at the circuit breaker.

Connect the power wires to the circuit breaker and switch the circuit breaker ON. If any module are installed, the Power LED will indicate the presence of power.

During the installation, ensure that the ground potentials are maintained throughout the system connections. This includes but not limited to the power source ground and any shielded cabling grounds.

Installation of the equipment should be such that the air flow in the front, back, side and top vents of the chassis are not compromised or restricted.

WARNING!!!
NEVER ATTEMPT TO OPEN THE CHASSIS OR SERVICE THE POWER SUPPLY. OPENING THE CHASSIS MAY CAUSE SERIOUS INJURY OR DEATH. THERE ARE NO USER REPLACEABLE OR SERVICEABLE PARTS IN THIS UNIT.

4) Connect Cables

- a. Insert the SFP Fiber transceiver into the SFP receptacle on the front of the module (see the SFP Data Sheet 091-17000-001 for supported Fast Ethernet transceivers).

NOTE: The release latch of the SFP Fiber transceiver must be in the closed (up) position before insertion.

- b. Connect an appropriate multimode or single-mode fiber cable to the fiber port on the front of the module. It is important to ensure that the transmit (TX) is attached to the receive side of the device at the other end and the receive (RX) is attached to the transmit side. When using single-fiber (SF) models, the TX wavelength must match the RX wavelength at the other end and the RX wavelength must match the TX wavelength at the other end.
- c. Connect the RJ-45 uplink port via an Ethernet Category 5 cable or better to an external 10/100 Ethernet device.
- d. Connect the 10/100 PoE RJ-45 port via an Ethernet Category 5 cable or better to an external 10/100 PoE/PoE+ powered device. Non-PoE devices can be connected to the RJ-45 port.

Description	IEEE 802.3af PoE	IEEE 802.3at PoE+
Power Supply Voltage Range	46.0 to 57.0 VDC	51.0 to 57.0 VDC
Voltage Range at PSE port Output	44.0 to 56.0 VDC	50.0 to 56.0 VDC
Maximum Power from PoE/PSE port	15.4 watts	30 watts
Minimum Voltage at PoE/PD port input*	37.0 VDC	42.5 VDC
Minimum Power at PoE/PD port*	12.95 watts	25.5 watts
* at 100 meters using Cat5		

5) Verify Operation

Verify the module is operational by viewing the LED indicators.

Power LED Indicators		
Legend	Indicator	Description
Pwr	OFF	Module not powered
	Green - ON	Module powered

Fixed Fiber or SFP Uplink Port LED Indicators		
Legend	Indicator	Description
100	OFF	Port not linked at 100Mbps
	Green - ON	Port linked at 100Mbps Full Duplex
	Green - Blinking at 10Hz	Port is transmitting or receiving frames at full duplex
	Green - Blinking at 1Hz	Port linked at 100Mbps and in redundant standby mode
	Amber - ON	Port linked at 100Mbps Half Duplex
	Amber - Blinking at 10Hz	Port is transmitting or receiving frames at half duplex
100 For Dual SFP Models	OFF	Port not linked at 100Mbps
	Green - ON	Port linked at 100Mbps Full Duplex
	Green - Blinking at 10Hz	Port is transmitting or receiving frames at full duplex
	Green - Blinking at 1Hz	Port linked at 100Mbps and in redundant standby mode
	Amber - ON	Port linked at 100Mbps Half Duplex
	Amber - Blinking at 10Hz	Port is transmitting or receiving frames at half duplex
	Amber - Blinking at 1Hz	Port is receiving FEFI

RJ-45 Uplink Port Indicators		
Legend	Indicator	Description
10	OFF	Port not linked at 10Mbps
	Green - ON	Port linked at 10Mbps Full Duplex
	Green - Blinking at 10Hz	Port is transmitting or receiving frames at full duplex
	Green - Blinking at 1Hz	Port linked at 10Mbps and in redundant standby mode
	Amber - ON	Port is linked at half duplex
	Amber - Blinking at 10Hz	Port is transmitting or receiving frames at half duplex
100	OFF	Port not linked at 100Mbps
	Green - ON	Port linked at 100Mbps Full Duplex
	Green - Blinking at 10Hz	Port is transmitting or receiving frames at full duplex
	Green - Blinking at 1Hz	Port linked at 100Mbps and in redundant standby mode
	Amber - ON	Port is linked at half duplex
	Amber - Blinking at 10Hz	Port is transmitting or receiving frames at half duplex

PoE RJ-45 Port Indicators		
Legend	Indicator	Description
10	OFF	Port not linked at 10Mbps
	Green - ON	Port linked at 10Mbps Full Duplex
	Green - Blinking at 10Hz	Port is transmitting or receiving frames at full duplex
	Amber - ON	Port is linked at half duplex
	Amber - Blinking at 10Hz	Port is transmitting or receiving frames at half duplex
100	OFF	Port not linked at 100Mbps
	Green - ON	Port linked at 100Mbps Full Duplex
	Green - Blinking at 10Hz	Port is transmitting or receiving frames at full duplex
	Amber - ON	Port is linked at half duplex
	Amber - Blinking at 10Hz	Port is transmitting or receiving frames at half duplex
PSE	OFF	Port PSE disabled
	Green - ON	Port PSE is active
	Green - Single Blink	Powered by 802.3af PoE (4 - 15W), class 0 - 3
	Green - two blinks	Powered by 802.3at PoE (30W), class 4
	Amber - ON	Failed PoE negotiation
	Amber - Blinking at 1Hz	Cannot provide requested current

MECHANICAL

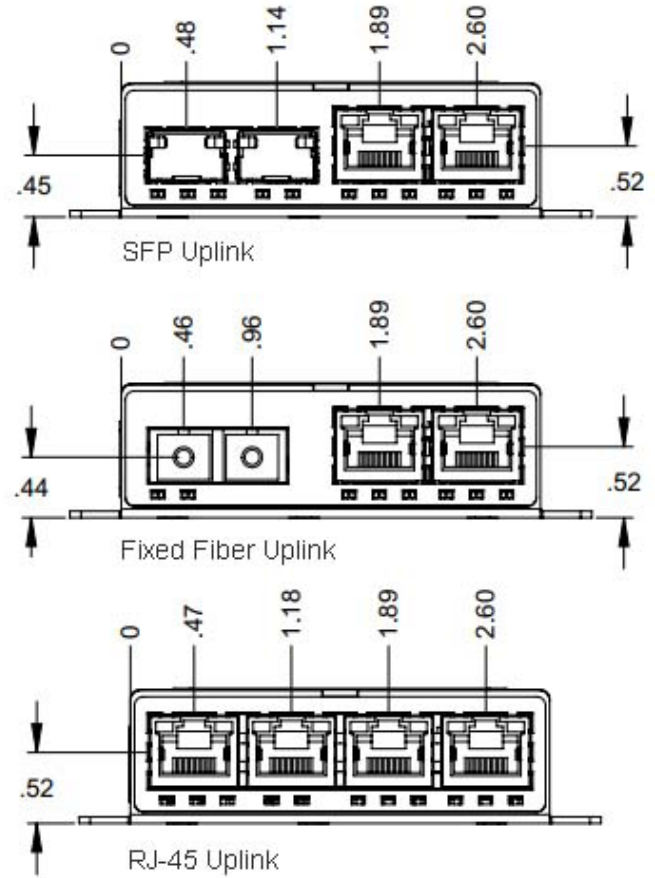

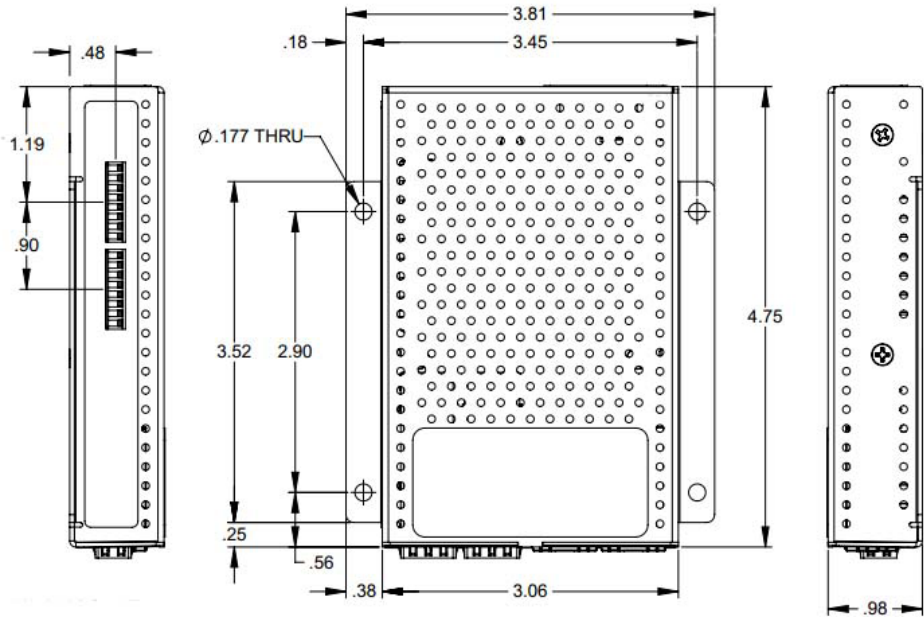
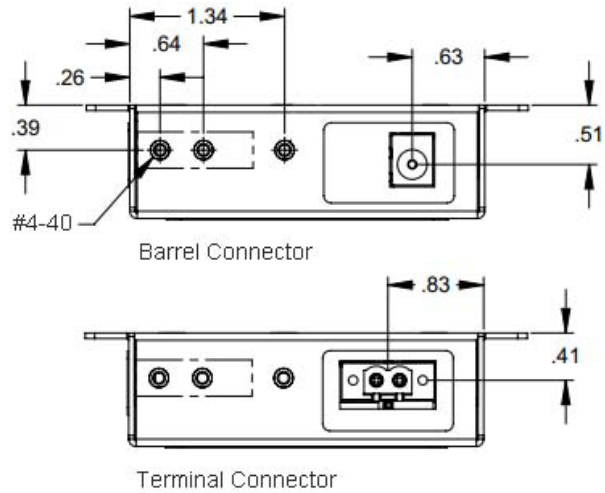

Ventilation holes may vary

Specifications

Standard Compliances	IEEE 802.3, 802.3af (15.40 watts) IEEE 802.3, 802.3at (30 watts)	
Environmental	RoHS, WEEE and REACH	
PoE Power Modes	IEEE Alternative A (Alt A)	
Frame Size	Up to 10,240 bytes	
Port Types	Copper: 10/100BASE-T (RJ-45) Fiber: 100BASE-X (ST, SC, SFP) 100BASE-BX (SC, SFP)	
Cable Types	Copper: EIA/TIA 568A/B, Cat 5 UTP and higher Fiber: Multimode: 50/125, 62.5/125µm Single-mode: 9/125µm	
AC Power Requirements (with AC/DC Adapters)	1 RJ-45 Port: 100 - 240VAC/50 - 60Hz, 0.33A @ 120VAC (typical)	2 RJ-45 Ports: 100 - 240VAC/50 - 60Hz, 0.62A @ 120VAC (typical)
DC Power Requirements (Models with DC Terminals)	1 RJ-45 Port: +/-46 to +/-57VDC, 0.78A @ 46VDC 2 Pin Terminal (isolated)	2 RJ-45 Ports: +/-46 to +/-57VDC, 1.45A @ 46VDC 2 Pin Terminal (isolated)
	A minimum DC input voltage of 50VDC is required to guarantee 25.5 watts (for 802.3at) at the end of 100 meters on Cat 5 cable or better.	
Dimensions (W x D x H)	3.8" x 4.8" x 1.0" (96.5 mm x 121.9 mm x 25.4 mm)	
Weight	Module Only: 1.0 lbs. (453.6 grams) Module w/ Adapter: 1.9 lbs. (852.6 grams)	
Operating Temperature (See Temperature Derating Table)	Commercial: 0 to 50°C Wide: -40 to 60°C (-20°C AC cold start) Extended: -40 to 75°C (-20°C AC cold start) Storage: -40 to 80°C	
Humidity	5 to 95% (non-condensing)	
Altitude	-100m to 4,000m	
MTBF (hrs)	Module: 584,000 AC/DC Adapter: 100,000	
Warranty	Lifetime warranty with 24/7/365 free Technical Support	

AC/DC Adapter Temperature Derating Total Available Wattage to RJ-45 Ports

Model	RJ-45 Ports	Watts Required	Watts Available @40°C	Watts Available @50°C	Watts Available @60°C	Watts Available @70°C	Watts Available @75°C
FPoE+/S	1	30 watts	Full Power	Full Power	Full Power	Full Power	Full Power
	2	60 watts	Full Power	Full Power	Full Power	Full Power	50 watts

The AC/DC Adapter Temperature derating table is not applicable to models with DC Terminal. The DC Terminal models will provide full PoE power over the operating temperature range of the module as long as the DC input power meets the requirements stated in the specification table.

Regulatory Compliances (Pending)	Safety:	UL 62368-1, UL 60950-1, IEC 62368-1, IEC 60950-1, CAN/CSA C22.2 No. 60950-1, EN 60950-1:2006 CE Mark, UKCA
	EMI:	FCC 47CFR, Part 15 Class A AS/NZS 3548, AS/NZS 4417.1 and AS/NZS 4417.2 ICES-003 Issue 3 EN 55032/CISPR 22 and EN55035 EN61000-3-2 VCCI V3/2001.04 (CISPR 22A:1997, Class A)
	EMS:	IEC/EN61000-4-2 IEC/EN61000-4-3; IEC/EN61000-4-4; IEC/EN61000-4-5; IEC/EN61000-4-6; IEC/EN61000-4-8; IEC/EN61000-4-11 IEC/EN61000-4-12 IEC/EN 61000-6-2 IEC/EN61000-6-4 IEC 60068-2-27 IEC 60068-2-6
	IP Rating:	IP30D Protection
	ACT:	TAA, BAA,NDAA

Customer Support Information

If you encounter problems while installing this product, contact Omnitron Technical Support:

Phone: (949) 250-6510

Fax: (949) 250-6514

Address: Omnitron Systems Technology, Inc.
38 Tesla
Irvine, CA 92618, USA

Email: support@omnitron-systems.com

URL: www.omnitron-systems.com