

## *Omniconverter*<sup>®</sup>

### **10GPoE+/S and 10GPoEBT/S**

Multi-Gigabit/Multi-Rate

10M, 100M, 1G, 2.5G, 5G, 10G

PoE Media Converters



## **User Manual**

### **General and Copyright Notice**

This publication is protected by U.S. and international copyright laws. All rights reserved. The whole or any part of this publication may not be reproduced, stored in a retrieval system, translated, transcribed, or transmitted, in any form, or by any means, manual, electric, electronic, electromagnetic, mechanical, chemical, optical or otherwise, without prior explicit written permission of Omnitron Systems Technology, Inc.

The following trademarks are owned by Omnitron Systems Technology, Inc.: FlexPoint™, FlexSwitch™, iConverter®, miConverter™, NetOutlook®, OmniLight®, OmniConverter®, RuggedNet®, Omnitron Systems Technology, Inc.™, OST™ and the Omnitron logo.

All other company or product names may be trademarks of their respective owners.

The information contained in this publication is subject to change without notice. Omnitron Systems Technology, Inc. is not responsible for any inadvertent errors.

### **Warranty**

This product is warranted to the original purchaser (Buyer) against defects in material and workmanship for a period of two (2) years from the date of shipment. A lifetime warranty may be obtained by the original purchaser by registering this product at [www.omnitron-systems.com/support](http://www.omnitron-systems.com/support) within ninety (90) days from the date of shipment. During the warranty period, Omnitron will, at its option, repair or replace a product which is proven to be defective with the same product or with a product with at least the same functionality.

For warranty service, the product must be sent to an Omnitron designated facility, at Buyer's expense. Omnitron will pay the shipping charge to return the product to Buyer's designated US address using Omnitron's standard shipping method.

### **Limitation of Warranty**

The foregoing warranty shall not apply to product malfunctions resulting from improper or inadequate use and/or maintenance of the equipment by Buyer, Buyer-supplied equipment, Buyer-supplied interfacing, unauthorized modifications or tampering with equipment (including removal of equipment cover by personnel not specifically authorized and certified by Omnitron), or misuse, or operating outside the environmental specification of the product (including but not limited to voltage, ambient temperature, radiation, unusual dust, etc.), or improper site preparation or maintenance.

No other warranty is expressed or implied. Omnitron specifically disclaims the implied warranties of merchantability and fitness for any particular purpose.

The remedies provided herein are the Buyer's sole and exclusive remedies. Omnitron shall not be liable for any direct, indirect, special, incidental, or consequential damages, whether based on contract, tort, or any legal theory.

## Environmental Notices

The equipment covered by this manual must be disposed of or recycled in accordance with the Waste Electrical and Electronic Equipment Directive (WEEE Directive) of the European Community directive 2012/19/EU on waste electrical and electronic equipment (WEEE) which, together with the RoHS Directive 2015/863/EU, for electrical and electronic equipment sold in the EU after July 2019. Such disposal must follow national legislation for IT and Telecommunication equipment in accordance with the WEEE directive: (a) Do not dispose waste equipment with unsorted municipal and household waste. (b) Collect equipment waste separately. (c) Return equipment using collection method agreed with Omnitron.



The equipment is marked with the WEEE symbol shown to indicate that it must be collected separately from other types of waste. In case of small items the symbol may be printed only on the packaging or in the user manual. If you have questions regarding the correct disposal of equipment go to [www.omnitron-systems.com/support](http://www.omnitron-systems.com/support) or e-mail to Omnitron at [intlinfo@omnitron-systems.com](mailto:intlinfo@omnitron-systems.com).

## Safety Warnings and Cautions



**ATTENTION:** Observe precautions for handling electrostatic discharge sensitive devices.



**WARNING:** Potential damage to equipment and personal injury.



**WARNING:** Risk of electrical shock.

## Customer Support Information

If you encounter problems while installing this product, contact Omnitron Technical Support:

Phone: (949) 250-6510  
Fax: (949) 250-6514  
Address: Omnitron Systems Technology, Inc.  
38 Tesla  
Irvine, CA 92618, USA  
Email: [support@omnitron-systems.com](mailto:support@omnitron-systems.com)  
URL: [www.omnitron-systems.com](http://www.omnitron-systems.com)

040-09192-001C 11/24

# OmniConverter® 10G PoE+/S and 10G PoE BT/S User Manual

## Product Overview

The OmniConverter 10G PoE+/S and 10G PoE BT/S are unmanaged 10G Ethernet multi-gigabit/multi-rate media converters featuring one 1/10G SFP/SFP+ uplink port and one or two multi-gigabit/multi-rate RJ-45 copper ports.

The RJ-45 ports support multi-gigabit/multi-rate speeds of 10Mbps, 100Mbps, 1Gbps, 2.5Gbps, 5Gbps and 10Gbps. The ports support IEEE 802.3at (15 and 30W) and IEEE 802.3bt (60 and 100W) per port depending on the model.

The 10G PoE+/S supports IEEE 802.3at PoE and the 10G PoE BT/S supports 60 and 100W IEEE 802.3bt PoE.

## Front Panel

The front of the module provides access to the RJ-45 ports and uplink ports.

## RJ-45 and Uplinks Ports

The RJ-45 Ethernet ports support multi-gigabit/multi-rate speeds of 10Mbps, 100Mbps, 1Gbps, 2.5Gbps, 5Gbps and 10Gbps protocols, auto-negotiation and auto MDI/MDI-X crossover.

The SFP/SFP+ transceiver receptacle port supports a variety of copper and fiber transceivers. It supports 10/100/1000BASE-T, 1000BASE-T, 100M/1G/2.5G/5G/10GBASE-T multi-gigabit copper transceivers and 1G and 10G multimode or single-mode fiber, dual or single-fiber transceivers in standard, CWDM and DWDM wavelengths.

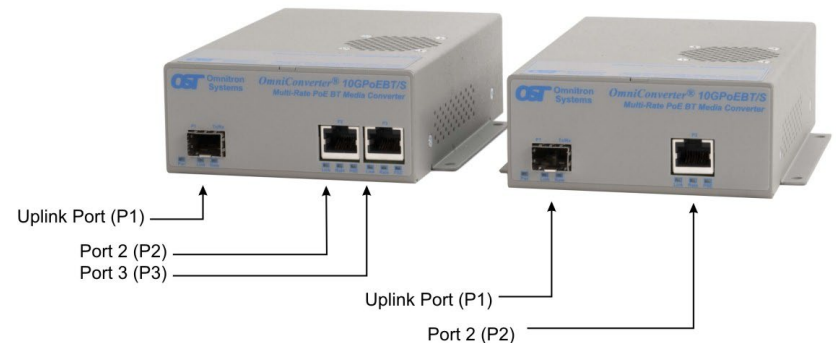

Front Panel Layout

## Installation Procedure

- 1) Configure DIP-switches
- 2) Installing the Module
- 3) Apply Power
- 4) Connect Cables
- 5) Verify Operation

## 1) Configure DIP-switches

DIP-switches are located on the side of the module. The DIP-switches are used to configure modes of operation, networking features and PoE settings.

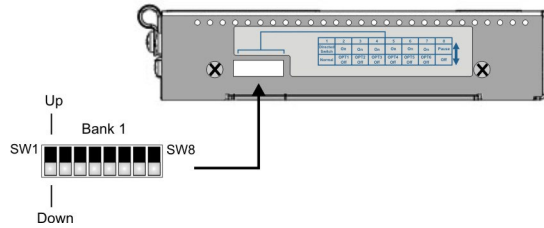

*DIP-switch Bank Locations*

The table below provides a description of each DIP-switch position and function for each model. Factory default is the DOWN position.

10GPoE+/S and 10GPoEBT/S				
Switch	Position	Top Legend	1 RJ-45 Models	2 RJ-45 Models
			Function	
SW1	DOWN	Normal	Reserved for future use	Normal Switch Enabled
	UP	Directed		Directed Switch Enabled
SW2	DOWN	Off	PoE Reset Port 2 Disabled	PoE Reset Port 2 Disabled
	UP	On	PoE Reset Port 2 Enabled	PoE Reset Port 2 Enabled
SW3*	DOWN	Off	Forced PoE Port 2 Disabled	Forced PoE Port 2 Disabled
	UP	On	Forced PoE Port 2 Enabled	Forced PoE Port 2 Enabled
SW4	DOWN	On	PoE Power Port 2 Enabled	PoE Power Port 2 Enabled
	UP	Off	PoE Power Port 2 Disabled	PoE Power Port 2 Disabled
SW5	DOWN	Off	Reserved for future use	PoE Reset Port 3 Disabled
	UP	On		PoE Reset Port 3 Enabled
SW6*	DOWN	Off	Reserved for future use	Forced PoE Port 3 Disabled
	UP	On		Forced PoE Port 3 Enabled
SW7	DOWN	On	Reserved for future use	PoE Power Port 3 Enabled
	UP	Off		PoE Power Port 3 Disabled
SW8	DOWN	Off	Pause Disabled	Pause Disabled
	UP	On	Pause Enabled	Pause Enabled
General Settings No DIP-switch Setting			MAC Learning Disabled	Mac Learning Enabled
			L2CP Frames Tunneled	L2CP Frames Tunneled

*DIP-switch Definitions for 10GPoE+/S and 10GPoEBT/S*

DIP-switches will vary depending on the port configuration of the media converter. Please refer to the table above for the desired port configuration.

**\*For 10GPoE+/S models, DIP-switches SW3 and SW6 are reserved for future use.**

## SW1: Mode Of Operation - “Normal / Directed”

**This DIP-switch is only supported on models with 2 RJ-45 ports. This DIP-switch is reserved for future use on all 1 RJ-45 port models.**

The module supports Normal Switch and Directed Switch mode.

The modes are described with MAC learning enabled. When MAC learning is disabled, unicast packets are forwarded to all ports.

### Normal Switch Mode

When this DIP-switch is in the factory default DOWN “Normal” position, the module is configured for Switch Mode. In this mode, the module operates as a standard layer 2 switch. Data flow will follow MAC address mapping.

### Directed Switch Mode (AKA Camera Mode)

When this DIP-switch is in the UP “Directed” position, the module is configured for Directed Switch Mode. In this mode, traffic from all the RJ-45 ports is only forwarded to the uplink port P1, preventing broadcast traffic from flooding the other network ports. Incoming traffic from uplink port P1 follows MAC address mapping.

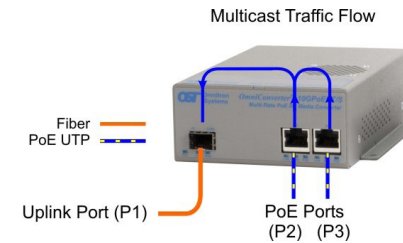

*Directed Switch Mode*

## SW2: PoE Reset Port 2 - “Off / On”

The port can be configured to reset the PoE output power for 5 seconds after a loss of receive link on the uplink port. This feature is typically used to allow a PD to re-initialize after a failure.

When this DIP-switch is in the factory default DOWN “Off” position, PoE output power on Port 2 will not reset on a loss of receive link on the uplink port. When this DIP-switch is in the UP “On” position, Port 2 will disable PoE output power for 5 seconds following a loss of receive link on the uplink port.

## SW3: Forced PoE on Port 2 - “Off / On”

**This DIP-switch is only supported on 10GPoEBT/S models. This DIP-switch is reserved for future use on all 10GPGPoE+/S models.**

This DIP-switch allows PoE power to be forced ON when connected to a PD with non-standard detection characteristics. The DIP-switch controls the forced capability for RJ-45 Port 2.

When this DIP-switch is in the factory default DOWN “Off” position, the RJ-45 port will automatically perform the detection, classification and powering functions for the attached PD. When this DIP-switch is in the UP “On” position, the RJ-45 port will provide up to a maximum of 100 watts of power (depending on the model) to the PD.

#### SW4: PoE Power Port 2 - “On / Off”

When this DIP-switch is in the factory default DOWN “On” position, PoE power on Port 2 is turned on. When this DIP-switch is in the UP “Off” position, PoE power on Port 2 is turned off and does not perform any PoE functions.

#### SW5: PoE Reset Port 3 - “Off / On”

**This DIP-switch is only supported on models with 2 RJ-45 ports. This DIP-switch is reserved for future use on all 1 RJ-45 port models.**

The port can be configured to reset the PoE output power for 5 seconds after a loss of receive link on the uplink port. This feature is typically used to allow a PD to re-initialize after a failure.

When this DIP-switch is in the factory default DOWN “Off” position, PoE output power on Port 3 will not reset on a loss of receive link on the uplink port. When this DIP-switch is in the UP “On” position, Port 3 will disable PoE output power for 5 seconds following a loss of receive link on the uplink port.

#### SW6: Forced PoE on Port 3 - “Off / On”

**This DIP-switch is only supported on 10GPoEBT/S models. This DIP-switch is reserved for future use on all 10PGPoE+/S models.**

This DIP-switch allows PoE power to be forced ON when connected to a PD with non-standard detection characteristics. The DIP-switch controls the forced capability for RJ-45 Port 3.

When this DIP-switch is in the factory default DOWN “Off” position, the RJ-45 port will automatically perform the detection, classification and powering functions for the attached PD. When this DIP-switch is in the UP “On” position, the RJ-45 port will provide up to a maximum of 100 watts of power (depending on the model) to the PD.

#### SW7: PoE Power Port 3 - “On / Off”

**This DIP-switch is only supported on models with 2 RJ-45 ports. This DIP-switch is reserved for future use on all 1 RJ-45 port models.**

When this DIP-switch is in the factory default DOWN “On” position, PoE power on Port 3 is turned on. When this DIP-switch is in the UP “Off” position, PoE power on Port 3 is turned off and does not perform any PoE functions.

#### SW8: Pause - “Off / On”

Setting the DIP-switch to the factory default DOWN “Off” position configures the module to advertise no Pause capability on all ports. Setting this DIP-switch to the UP “On” position configures the module to advertise Symmetrical and Asymmetrical Pause capability to all ports.

## 2) Installing the Module

### Wall Mounting

The wall mounting height of the module should be less than or equal to 2 meters (6.6 feet) from the floor. Use the four mounting holes on the module to secure the module to the wall. The module can accommodate #6 screws (not included).

Installation of the module should be such that the air flow in the front, back, side and top vents of the module are not compromised or restricted.

The accessory cables should have their own strain relief and do not pull down on the module.

### Rack Mounting

The module can be rack mounted using the optional Rack Mount Shelf (8260-0). Refer to the Rack Mount Shelf user manual (040-08260-001x) for the proper installation guidelines. The user manual is available on the iConverter Rack Mount Shelf product page at: [www.omnitron-systems.com](http://www.omnitron-systems.com)

## 3) Apply Power

### AC Power

Secure the ground wire to the ground screw. See the figure below for the location of the grounding screws.

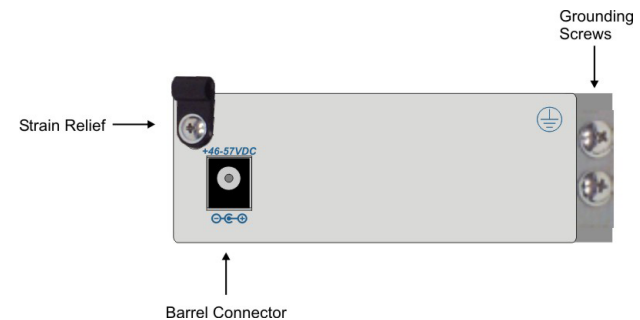

*AC Models Rear View: Barrel Connector for AC/DC Power Adapter*

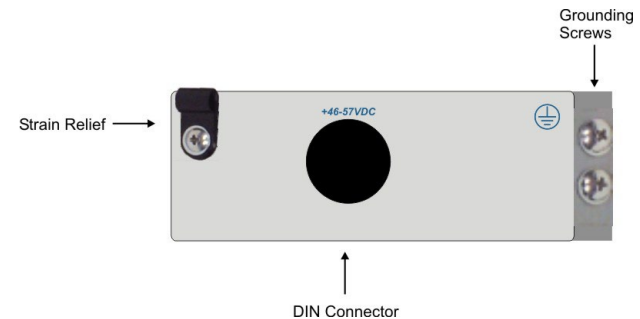

*AC Models Rear View: DIN Connector for AC/DC Power Adapter*

Route the power cord through the provided strain relief for additional support and connect the barrel or DIN connector (depending on the model) at the end of the wire on the AC/DC adapter to the barrel or DIN connector on the module. Connect the AC/DC adapter to the AC outlet. Confirm that the module has powered up properly by checking the Power LED located on the front of the switch.

The AC power requirements for each port configuration is outlined in the table below. Voltage ranges are inclusive of tolerances.

	10GPoE+/S	10GPoEBT/S	
		60W Models	100W Models
<b>1 RJ-45 Port</b>	100 to 240VAC 50 to 60Hz 0.40A @ 120VAC 2.1 mm Barrel	100 to 240VAC 50 to 60Hz 0.69A @ 120VAC 2.1 mm Barrel	100 to 240VAC 50 to 60Hz 1.08A @ 120VAC DIN-6 Connector
<b>2 RJ-45 Ports</b>	100 to 240VAC 50 to 60Hz 0.72A @ 120VAC 2.1 mm Barrel	100 to 240VAC 50 to 60Hz 1.30A @ 120VAC DIN-6 Connector	100 to 240VAC 50 to 60Hz 2.08A @ 120VAC DIN-6 Connector

Make sure to disconnect the power and ground cables before removing the module.

**WARNING!!!**  
NEVER ATTEMPT TO OPEN THE CHASSIS OR SERVICE THE POWER SUPPLY. OPENING THE CHASSIS MAY CAUSE SERIOUS INJURY OR DEATH. THERE ARE NO USER REPLACEABLE OR SERVICEABLE PARTS IN THIS UNIT.

### DC Power

This module is intended for installation in restricted access areas. (“Les matériels sont destinés à être installés dans des EMBLEMES À ACCÈS RESTREINT”). A restricted access area can be accessed only through the use of a special key, or other means of security.

The over current protection for connection with centralized DC shall be provided in the building installation, and shall be a UL listed circuit breaker rated 20 Amps, and installed per the National Electrical Code, ANSI/NFPA-70.

The DC power requirements for each port configuration is outlined in the table below. Voltage ranges are inclusive of tolerances.

	10GPoE+/S	10GPoEBT/S	
		60W Models	100W Models
<b>1 RJ-45 Port</b>	+46 to +57VDC; 0.74A @ 56VDC 2 Pin Terminal	+46 to +57VDC; 1.28A @ 56VDC 2 Pin Terminal	+46 to +57VDC; 2.00A @ 56VDC 2 Pin Terminal
<b>2 RJ-45 Ports</b>	+46 to +57VDC; 1.34A @ 56VDC 2 Pin Terminal	+46 to +57VDC; 2.43A @ 56VDC 2 Pin Terminal	+46 to +57VDC; 3.87A @ 56VDC 2 Pin Terminal

Appropriate overloading protection should be provided on the DC power source outlets utilized.

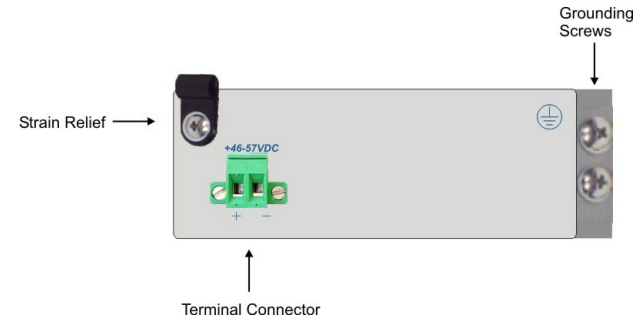

*DC Models Rear View: 2-Pin Terminal for DC Power*

**WARNING REGARDING EARTHING GROUND:**

- This equipment shall be connected to the DC supply system earthing electrode conductor or to a bonding jumper from an earthing terminal bar or bus to which the DC supply system earthing electrode is connected.
- This equipment shall be located in the same immediate area (such as adjacent cabinets) as any other equipment that has a connection between the earthed conductor of the same DC supply circuit and the earthing conductor, and also the point of earthing of the DC system. The DC system shall not be earthed elsewhere.
- The DC supply source is to be located within the same premises as this equipment.
- There shall be no switching or disconnecting devices in the earthed circuit conductor between the DC source and the earthing electrode conductor.

**WARNING:** Only a DC power source that complies with safety extra low voltage (SELV) requirements can be connected to the DC-input power supply.

Locate the DC circuit breaker of the external power source, and switch the circuit breaker to the OFF position.

Prepare a power cable using a three conductor insulated wire (not supplied) with 12AWG to 14AWG thickness. Cut the power cable to the length required.

Strip approximately 3/8 of an inch of insulation from the power cable wires.

Connect the ground wire to the grounding screws on the back of the module.

Connect the power cables to the module by fastening the stripped ends to the DC power connector.

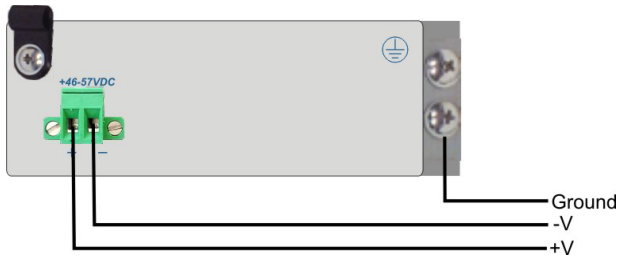

DC Models Rear View: Power Connections

**WARNING:** The positive lead of the power source must be connected to the “+” terminal on the module and the negative lead of the power source to the “-“ terminal on the module as shown above.

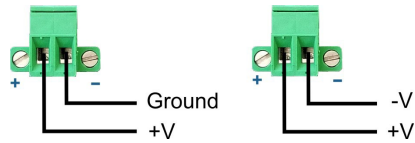

Power Options

**WARNING:** Note the wire colors used in making the positive, negative and ground connections. Use the same color assignment for the connection at the circuit breaker.

Connect the power wires to the circuit breaker and switch the circuit breaker ON. If any module are installed, the Power LED will indicate the presence of power.

During the installation, ensure that the ground potentials are maintained throughout the system connections. This includes but not limited to the power source ground and any shielded cabling grounds.

**WARNING!!!**  
 NEVER ATTEMPT TO OPEN THE CHASSIS OR SERVICE THE POWER SUPPLY. OPENING THE CHASSIS MAY CAUSE SERIOUS INJURY OR DEATH. THERE ARE NO USER REPLACEABLE OR SERVICEABLE PARTS IN THIS UNIT.

Make sure to disconnect the power and ground cables before removing the equipment.

#### 4) Connect Cables

- a. Insert the SFP/SFP+ transceiver into the SFP receptacle on the front of the module. Refer to the SFP or SFP+ data sheets for supported 1G and 10G transceivers. The data sheets are available on the XFP, SFP+ and SFP Transceiver product page at: [www.omnitron-systems.com](http://www.omnitron-systems.com)

**NOTE:** The release latch of the SFP fiber transceiver must be in the closed (up) position before insertion.

- b. Connect an appropriate multimode or single-mode fiber cable to the fiber port on the front of the module. It is important to ensure that the transmit (TX) is attached to the receive side of the transceiver at the other end and the receive (RX) is attached to the transmit side. When using single-fiber (SF) models, the TX wavelength must match the RX wavelength at the other end and the RX wavelength must match the TX wavelength at the other end.
- c. Connect the RJ-45 Ethernet port using the appropriate cable type for the speed of the interface (see Specification Table) to an external Ethernet device. The RJ-45 Ethernet ports support multi-rate speeds of 10Mbps, 100Mbps, 1Gbps, 2.5Gbps, 5Gbps and 10Gbps.

Description	15W IEEE 802.3af PoE	30W IEEE 802.3at PoE+	60W IEEE 802.3bt PoE (Type 3)	100W IEEE 802.3bt PoE (Type 4)
Power Supply Voltage Range	46.0 to 57.0 VDC	51.0 to 57.0 VDC	51.0 to 57.0 VDC	53.0 to 57.0 VDC
Voltage Range at PSE port Output	44.0 to 56.0 VDC	50.0 to 56.0 VDC	50.0 to 56.0 VDC	52.0 to 56.0 VDC
Maximum Power from PoE/PSE port	15.4 watts	30 watts	60 watts	100 watts
Minimum Voltage at PoE/PD port input*	37.0 VDC	42.5 VDC	42.5 VDC	41.1 VDC
Minimum Power at PoE/PD port*	12.95 watts	25.5 watts	51 watts	71 watts

\* at 100 meters using Cat5

PoE, PoE+ and 803.2bt Requirements

## 5) Verify Operation

Verify the module is operational by viewing the LED indicators.

Power LED Indicators		
Legend	Indicator	Description
Pwr	OFF	Unit not powered
	Green - ON	Unit powered

### *Power LED Indicators*

Uplink Ports LED Indicators		
Legend	Indicator	Description
Link	OFF	Port Not Linked
	Green - ON	Port linked at the speed indicated by the Rate LED
	Green - Blinking at 10Hz	Port is transmitting or receiving data at the rate indicated by the Rate LED
Rate	OFF	No link
	Green - one blink	Port linked at 10M, 100M or 1G
	Green - two blinks	Port linked at 2.5G
	Green - three blinks	Port linked at 5G
	Green - four blinks	Port linked at 10G

When the uplink port is installed with an RJ-45 SFP+ transceiver, the LED will indicate the speed of the connection as shown above.

### *Uplink Ports LED Indicators*

RJ-45 Ports LED Indicators		
Legend	Indicator	Description
Link	OFF	Port Not Linked
	Green - ON	Port linked at the speed indicated by the Rate LED
	Green - Blinking at 10Hz	Port is transmitting or receiving data at the rate indicated by the Rate LED
Rate	OFF	No link
	Green - one blink	Port linked at 10M, 100M or 1G
	Green - two blinks	Port linked at 2.5G
	Green - three blinks	Port linked at 5G
	Green - four blinks	Port linked at 10G

### *RJ-45 LED Indicators*

PSE LED Indicators		
Legend	Indicator	Description
PSE	OFF	Port PSE inactive
	Amber - ON	Failed PoE Negotiation
	Amber - Blinking at 1Hz	Cannot provide the requested power
	Green - single blink	PoE (4-15W), class 0-3 detected
	Green - two blinks	PoE+ (30W), class 4 detected
	Green - three blinks	4PPoE (45W, 60W), class 5-6 detected
	Green - four blinks	4PPoE (75W, 100W), class 7-8 detected

### *PSE LED Indicators*

## Specifications

<b>Description</b>	<b>OmniConverter 10GPoE+/S</b> Multi-gigabit/multi-rate copper to 1/10G SFP Media Converter with IEEE 802.3at 15/30W
<b>Standard Compliances</b>	IEEE 802.3, 802.3bz, IEEE 802.3af (15.4 watts max) IEEE 802.3at (30 watts max)
<b>PoE Supported Modes</b>	IEEE Alternate A (Alt A)
<b>Environmental</b>	RoHS, WEEE, REACH
<b>Frame Size</b>	Up to 10,240 bytes
<b>Port Types</b>	Copper: 10/100/1000BASE-T, 2.5GBASE-T/5GBASE-T/10GBASE-T (RJ-45) SFP/SFP+: 10GBASE-X Fiber Transceivers, 10GBASE-T Copper Transceivers 1000BASE-X Fiber Transceivers, 1000BASE-T Copper Transceivers 10/100/1000BASE-T SGMII Copper Transceivers 10/100/1000/2.5G/5G/10GBASE-T Multi-rate Copper Transceivers
<b>Cable Types</b>	Copper: Twisted-pair cable up to 100 meters 10BASE-T: 4-pair UTP Cat 3, 4, 5, 5e, 6, 6A 100BASE-TX: 4-pair UTP Cat 5, 5e, 6, 6A 1G/2.5G: 4-pair UTP Cat 5e, 6, 6A, 7 5G: 4-pair UTP Cat 6, 6A, 7 10G: 4-pair UTP Cat 6A, 7 Fiber: Multimode: 50/125, 62.5/125µm Single-mode: 9/125µm
<b>Dimensions W x D x H</b>	4.8" x 6.0" x 1.75" (121.92 mm x 152.4 mm x 44.45 mm)
<b>Weight</b>	Module Only: 1.1 lbs. (498.9 grams) Module w/ Adapter: 3.2 lbs. (1451.5 grams)
<b>Operating Temperature</b>	Commercial: 0 to 50°C Wide: -40 to 60°C (-20°C AC cold start) Storage: -40 to 80°C
<b>Humidity</b>	5 to 95% (non-condensing)
<b>Altitude</b>	-100m to 4,000m
<b>MTBF (hours)</b>	Module Only: 265,000 AC/DC Adapter: 100,000
<b>Warranty</b>	Lifetime warranty with registration and 24/7/365 free Technical Support

<b>Description</b>	<b>OmniConverter 10GPoEBT/S</b>	
		Multi-gigabit/multi-rate copper to 1/10G SFP Media Converter with IEEE 802.3bt 60W
<b>Standard Compliances</b>	IEEE 802.3, 802.3bz, IEEE 802.3af (15.4 watts max) IEEE 802.3at (30 watts max) IEEE 802.3bt (60 watts max)	IEEE 802.3, 802.3bz IEEE 802.3af (15.4 watts max) IEEE 802.3at (30 watts max) IEEE 802.3bt (100 watts max)
<b>PoE Supported Modes</b>	IEEE Alternate A (Alt A) and 4 Pair	
<b>Environmental</b>	RoHS, WEEE, REACH	
<b>Frame Size</b>	Up to 10,240 bytes	
<b>Port Types</b>	Copper: 10/100/1000BASE-T, 2.5GBASE-T/5GBASE-T/10GBASE-T (RJ-45) SFP/SFP+: 10GBASE-X Fiber Transceivers, 10GBASE-T Copper Transceivers 1000BASE-X Fiber Transceivers, 1000BASE-T Copper Transceivers 10/100/1000BASE-T SGMII Copper Transceivers 10/100/1000/2.5G/5G/10GBASE-T Multi-rate Copper Transceivers	
<b>Cable Types</b>	Copper: Twisted-pair cable up to 100 meters 10BASE-T: 4-pair UTP Cat 3, 4, 5, 5e, 6, 6A 100BASE-TX: 4-pair UTP Cat 5, 5e, 6, 6A 1G/2.5G: 4-pair UTP Cat 5e, 6, 6A, 7 5G: 4-pair UTP Cat 6, 6A, 7 10G: 4-pair UTP Cat 6A, 7 Fiber: Multimode: 50/125, 62.5/125µm Single-mode: 9/125µm	
<b>Dimensions W x D x H</b>	4.8" x 6.0" x 1.75" (121.92 mm x 152.4 mm x 44.45 mm)	
<b>Weight</b>	Module Only: 1.1 lbs. (498.9 grams) Module w/ Adapter: 3.2 lbs. (1451.5 grams)	Module Only: 1.1 lbs. (498.9 grams) Module w/ Adapter: 3.7 lbs. (1678.3 grams)
<b>Operating Temperature</b>	Commercial: 0 to 50°C Wide: -40 to 60°C (-20°C AC cold start) Storage: -40 to 80°C	
<b>Humidity</b>	5 to 95% (non-condensing)	
<b>Altitude</b>	-100m to 4,000m	
<b>MTBF (hours)</b>	Module Only: 263,000 AC/DC Adapter: 100,000	
<b>Warranty</b>	Lifetime warranty with registration and 24/7/365 free Technical Support	

<b>Regulatory Compliances</b>	Safety:	UL 62368-1*, UL 60950-1*, IEC 62368-1*, IEC 60950-1*, EN 62368-1*, EN 60950-1*, CAN/CSA C22.2 No. 62368-1-14*, CAN/CSA C22.2 No. 60950-1*, CE Mark, UKCA
	EMC:	EN 55032/24 CE Emissions/Immunity, UKCA
	EMI:	CISPR 32, FCC 47 Part 15 Subpart B Class A
	EMS:	IEC 61000-4-2 ESD: Contact: 6 kV; Air: 8 kV, IEC 61000-4-3 RS: 80 MHz to 1 GHz: 3 V/m, IEC 61000-4-4 EFT: Power: 2 kV; Signal: 2 kV (DC models), IEC 61000-4-4 EFT: Power: 1 kV; Signal: 1 kV (AC models), IEC 61000-4-5 Surge: Power: 2 kV; Signal: 2 kV (DC models), IEC 61000-4-5 Surge: Power: 1 kV Line/Line; 2 kV Line/Gnd; Signal: 2 kV (AC models), IEC 61000-4-6 CS: Signal: 3 Vrms, IEC 61000-4-8 (Magnetic Field) 30 A/m, IEC 61000-4-11 (Voltage Dips, interrupts)
	IP Rating: ACT:	IP20 Protection TAA, BAA,NDAA

\* Pending

## Mechanical

1 RJ-45 Port  
9191-01-11  
9192B-0-11  
9194B-0-11

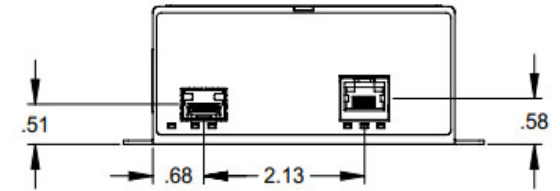

2 RJ-45 Ports  
9191-0-12  
9192B-0-12  
9194B-0-12

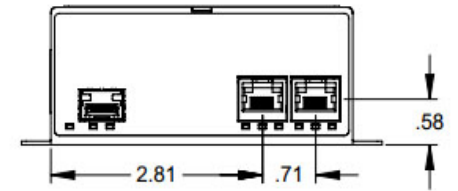

AC DIN  
Power Option 1,2,8  
9191B-0-12  
9194B-0-11  
9194B-0-12

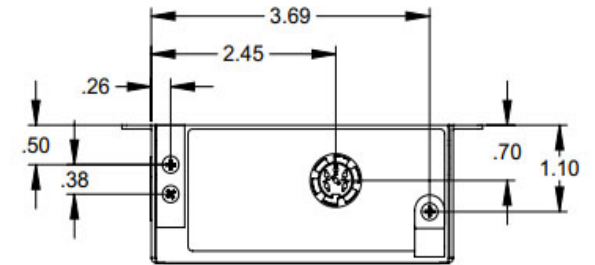

AC Barrel  
Power Option 1,2,8  
9191-0-11  
9191-0-12  
9192B-0-11

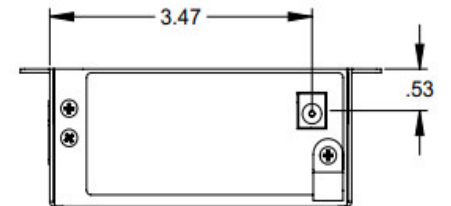

DC Terminal  
Power Option 9  
All models

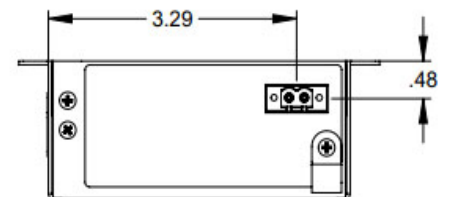

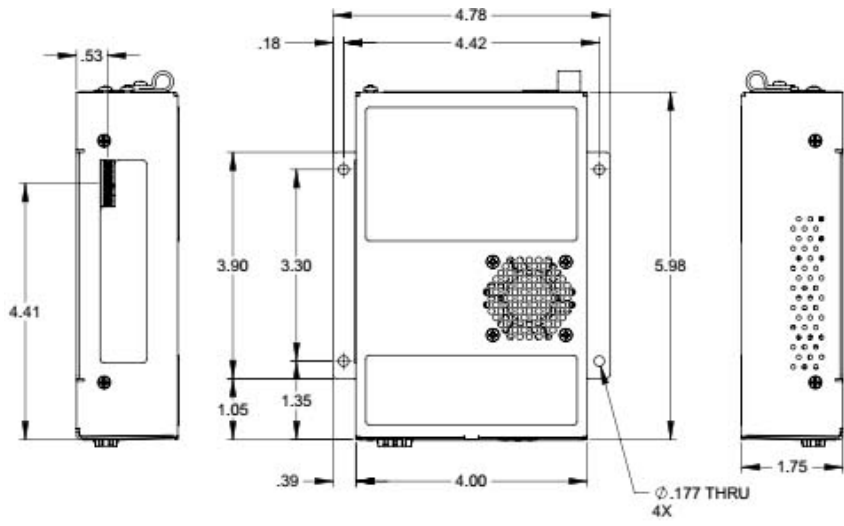

Intentionally left blank