

miConverter® GX/T PoE/D

10/100/1000BASE-T to 100/1000BASE-X Ethernet Media Converters with PoE Powering

The miniature miConverter GX/T PoE/D is a rate-switching 10/100/1000 RJ-45 copper to 100/1000BASE-X fiber media converter that can be powered with Power over Ethernet (PoE) when connected to PoE switches and midspans. It can also be powered with DC power or AC power with an external power adapter. The miConverter GX/T PoE/D miniature Ethernet media converters provide cost-effective copper-to-fiber connectivity solutions. Due to their size, portability, and low power consumption, they are ideal for fiber-to-the-desktop/laptop under the desk deployments and mission-critical field diagnostic applications.

The miConverter GX/T PoE/D features fixed fiber connectors and Small Form Pluggable (SFP) transceivers. ST, SC and LC fixed fiber connectors support multimode, single-mode, and single-mode single-fiber. 100BASE-X and 1000BASE-X SFP transceivers enable adaptability to different datarates, fiber types and wavelengths, including Coarse Wave Division Multiplexing (CWDM) wavelengths to increase the bandwidth capacity of fiber infrastructure.

The RJ-45 port can auto-negotiate by detecting the speed and duplex-mode of the connected device. Upon connection to the UTP device, the RJ-45 port speed adjusts to either 10Mbps, 100Mbps or 1000Mbps, and the duplex-mode adjusts to either Full-Duplex or Half-Duplex. Auto-crossover enables the connection to workstations (MDI port) or hub/switches (MDI-X port) without requiring a crossover cable.

DIP-switches enable manual configuration of the RJ-45 port speed and duplex modes, and configuration of Link Modes (fault-detection capabilities) that enable in the identification and isolation of link failures.

Diagnostic data is provided through front-panel LED indicators that assist in network installation and maintenance. The LEDs display the availability of power, port activity, link status, and the speed and duplex modes of the RJ-45 port.

The miConverter GX/T PoE/D features power redundancy with AC or DC external power options when used with PoE powering. AC power adapter is available in US, Universal and Country/Region specific models. Country/Region specific models feature optional interchangeable connectors, allowing for compatibility with electrical outlet types found around the world. DC power up to 60VDC is available with a terminal connector option.

The miConverter GX/T PoE/D is available with or without integrated mounting brackets. miConverter GX/T PoE/D models without integrated mounting brackets can be installed in the miConverter 18-Module Powered Chassis.



SFP not included

KEY FEATURES

- Cost-effective, miniature 10/100/1000BASE-T to 100/1000BASE-X Ethernet Powered Device (PD)
- Supports 10BASE-T, 100BASE-TX, 1000BASE-T, 100BASE-X, 1000BASE-X and IEEE 802.3 specifications
- Supports jumbo frames up to 10,240 bytes
- Fixed fiber port supports multimode and single-mode dual fiber with ST, SC and LC connectors; and single-mode single-fiber with SC connectors
- 100Mbps and 1Gbps SFP transceivers for standard or CWDM wavelengths
- RJ-45/PoE port supports Full/Half-Duplex auto-negotiation and MDI/MDIX auto-crossover
- LED indicators for RJ-45 and fiber port status
- User-selectable link fault detection modes facilitate quick fault detection, isolation and reporting
- Automatic Link Recovery
- Power-over-Ethernet (IEEE 802.3af PoE/PD) with redundant power options:
 - Wide Range DC Power input 8-60VDC (2-Pin Terminal) or
 - US, Universal and Country/Region specific AC power adapter (Barrel Connector)
- Available with or without integrated mounting brackets
- Models without integrated mounting brackets can be installed in an 18-Module Powered Chassis
- Commercial (0 to 50°C) and Wide (-40° to 60°C) temperature ranges
- TAA, BAA and NDAA compliant, and Made in the USA
- Lifetime Warranty and free 24/7 Technical Support

APPLICATION EXAMPLES

Fiber Distance Extension with PoE

PoE switches are used to provide data and power via copper UTP cabling to Powered Devices (PDs) such as VoIP phones, Wi-Fi Access Points and IP cameras. When the distance to the PD exceeds the 100 meter distance limitation of UTP cable, fiber can be deployed to extend the distance to PDs in remote locations.

The application example below shows how miConverter GX/T PoE/D converters are deployed to enable plug-and-play fiber connectivity from PoE switches.

The miConverter GX/T PoE/D is powered by a UTP patch cable and converts the copper to fiber to connect to a remote PoE IP camera. At the remote end of the fiber run, an OmniConverter PoE power-sourcing media converter converts the fiber back to copper and injects PoE (up to 60W) to power the IP camera. The OmniConverter is powered by AC power and injects up to 60W PoE.

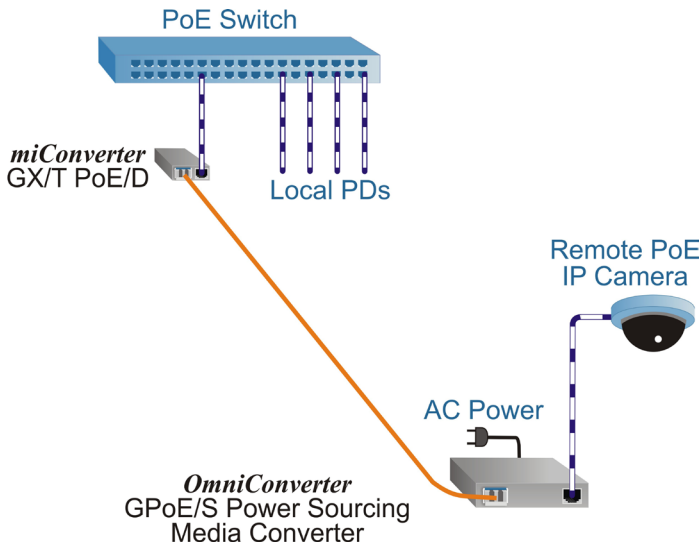

Fiber to the Premises

In the application example shown below, the miConverter GX/T PoE/D provides outdoor media conversion for an FTTx service without an outdoor power source.

A Service Provider deploys the miConverter GX/T PoE/D in a NEMA enclosure on the outside wall of a customer premises for fiber to copper conversion that provides connectivity to the indoor demarcation router.

The miConverter GX/T PoE/D is powered by a midspan located inside the customer premises. This enables fast and simple installation of the media converter, and eliminates the cost of installing an outdoor power outlet.

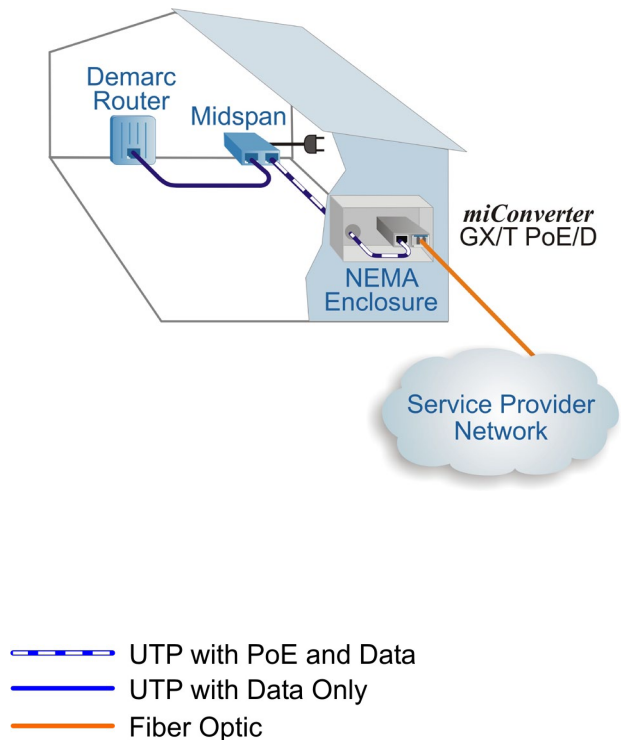

CHASSIS OPTIONS

miConverter GX/T PoE/D models without integrated mounting brackets can be installed in the miConverter 18-Module Powered Chassis to consolidate modules into a rack-mount form factor and distribute multiple fiber optic links from PoE switch equipment. Only miConverter GX/T PoE/D models with AC barrel connectors can be installed in the chassis.

The chassis provides power to the modules with barrel-style DC connectors, and is available with an integrated universal AC, 24VDC or 48VDC power supply.

The compact, high-density chassis is 1.5 rack units high, and can be mounted in a standard 19" or 23" equipment rack.



ACCESSORIES

Model Number	Description
1020-1	18-Module AC Powered Chassis*
1025-1	18-Module 48VDC Powered Chassis*
1026-1	18-Module 24VDC Powered Chassis*
1091-0	Wall Mounting Hardware Kit
8252-0	DIN Rail Mounting Clip
9119-PSE	Spare JET/PSE certified Universal AC/DC Power Adapter for Wide and Extended temperature models (no power cord)
9129-PS	Spare Universal AC/DC Power Adapter for Wide and Extended temperature models (no power cord)
Contact Omnitron for replacement power adapters and other accessories. * Not for use with Extended temperature or DC Terminal Connector models.	

SPECIFICATIONS

<i>miConverter GX/T PoE/D</i>	
Description	10/100/1000BASE-T to 100/1000BASE-X Fiber Converter Powered by PoE
Standard Compliances	IEEE 802.3, 802.3af
Regulatory Compliances	Safety: UL, cUL, CE, UKCA EMI: FCC Class A ACT: TAA, BAA, NDA
Environmental	RoHS, REACH, WEEE
Frame Size	Up to 10,240 bytes
Port Types	Copper: 10/100/1000BASE-T (RJ-45) Fiber: 100BASE-X (SFP) 1000BASE-X (ST, SC, LC, SFP)
Cable Types	Copper: EIA/TIA 568A/B, Cat 5 UTP and higher Fiber: Multimode: 50/125µm, 62.5/125µm Single-mode: 9/125µm
AC Power Requirements	AC/DC Adapter: 100 - 240VAC/50 - 60Hz 0.03A @ 120VAC (max)
DC Power Requirements	DC Input: (AC/DC Adapter) 8.0 to 60.0VDC 0.278A @ 9VDC 2.5mm Barrel Connector
	DC Input: (Terminal Connector) 8.0 to 60.0VDC 0.278A @ 9VDC 2-Pin Terminal (non-isolated)
	DC Input: (PoE) 44 - 57VDC, 0.05A @ 48VDC (typical) RJ-45 (Alternative A & B)
Dimensions W x D x H	Standalone: 1.71" x 4.10" x 0.84" (43.4 mm x 104.1 mm x 21.3 mm)
	Standalone w/Integrated Brackets 2.41" x 4.10" x 0.84" (61.2 mm x 104.1 mm x 21.3 mm)
Weight	Module Only: 4 oz. (113.4 grams) With AC/DC Adapter: 12 oz. (340.2 grams)
Temperature	Commercial: 0 to 50°C Wide: -40 to 60°C, -20°C AC cold start Storage: -50 to 85°C
Humidity	5 to 95% (non-condensing)
Altitude	-100m to 4,000m
MTBF (hrs)	Module Only: 859,588
	With AC/DC Adapter: 102,249
Warranty	Lifetime warranty with 24/7/365 free Technical Support

ORDERING INFORMATION

Step 1: Choose a Base Part Number (xxxx-x-pt)

Fiber Type	Distances	Connector Types				Tx / Rx Lambda (nm)	Min. Tx Power (dBm)	Max. Tx Power (dBm)	Min. Rx Power (dBm)	Max. Rx Power (dBm)	Min Attenuation (dB)	Link Budget (dB)
		ST	SC	LC	SFP							
-	-	-	-	-	1239D-0-bpt	-	-	-	-	-	-	
MM/DF	220 / 550m ¹	1220D-0-bpt	1222D-0-bpt	1226D-0-bpt	-	850 / 850	-10	-4	-17	-3	-	7
SM/DF	12km	1221D-1-bpt	1223D-1-bpt	1227D-1-bpt	-	1310 / 1310	-9.5	-3	-19.5	-3	-	10
SM/DF	34km	1221D-2-bpt	1223D-2-bpt	-	-	1310 / 1310	-5	0	-23	-3	3	18
SM/DF	80km	-	1223D-3-bpt	-	-	1550 / 1550	-5	0	-23	-3	3	18
SM/DF	110km	-	1223D-4-bpt	-	-	1550 / 1550	0	5	-24	-3	8	24
SM/DF	140km	-	1223D-5-bpt	-	-	1550 / 1550	2	5	-28	-8	13	30
MM/SF ²	550m	-	1230D-0-bpt	-	-	1310 / 1550	-9	-3	-18	-3	-	9
MM/SF ²	550m	-	1231D-0-bpt	-	-	1550 / 1310	-9	-3	-18	-3	-	9
SM/SF ²	20km	-	1230D-1-bpt	-	-	1310 / 1550	-9.5	-3	-20	-3	-	10.5
SM/SF ²	20km	-	1231D-1-bpt	-	-	1550 / 1310	-9.5	-3	-20	-3	-	10.5
SM/SF ²	40km	-	1230D-2-bpt	-	-	1310 / 1550	-3	0	-20	-3	3	17
SM/SF ²	40km	-	1231D-2-bpt	-	-	1550 / 1310	-3	0	-20	-3	3	17

¹ 62.5/125µm (OM1) multimode fiber up to 220m. 50/125µm (OM2) multimode fiber up to 550m.

² When using single-fiber (SF) media converter models, the Tx wavelength on one end has to match the Rx wavelength on the other.

MM = Multimode, SM = Single-mode, DF = Dual Fiber, SF = Single-fiber

Contact Omnitron for other fiber options. Order the appropriate SFPs separately. [Visit the Omnitron Optical Transceivers web page.](#)

Step 2: Choose a Mounting Bracket Option (xxxxD-x-bpt)

0 = Without Integrated Mounting Brackets
1 = With Integrated Mounting Brackets

Step 3: Choose a Power Option (xxxxD-x-bpt)

0 = PoE/PD Power, Barrel Connector, No AC/DC Power Adapter
1 = PoE/PD Power, Barrel Connector and AC/DC Power Adapter with 100-240VAC, 50-60Hz, with US power clip
2 = PoE/PD Power, Barrel Connector and Universal AC/DC Power Adapter with 100-240VAC, 50-60Hz (requires AC power cord)
3 = PoE/PD Power, Barrel Connector and AC/DC Power Adapter with 100-240VAC, 50-60Hz, with European power clip
4 = PoE/PD Power, Barrel Connector and AC/DC Power Adapter with 100-240VAC, 50-60Hz, with UK power clip
5 = PoE/PD Power, Barrel Connector and AC/DC Power Adapter with 100-240VAC, 50-60Hz, with Australian power clip
8 = PoE/PD Power, Barrel Connector and AC/DC Power Adapter with 100-240VAC, 50-60Hz, with US/Japan power clip
9 = PoE/PD Power, 2 Pin DC Terminal Connector 8-60VDC, No Power Adapter

Step 4: Choose an Operating Temperature Option (xxxxD-x-bpt)

<leave blank> = Commercial temperature (0 to 50°C)
W = Wide temperature (-40 to 60°C)

© 2025 Omnitron Systems Technology, Inc. miConverter is a registered trademark of Omnitron Systems Technology, Inc. Trademarks are owned by their respective companies. Specifications subject to change without notice. All rights reserved.

