

### miConverter<sup>®</sup> 18-Module Chassis

Rack-Mount Chassis for *miConverter* Media Converter Modules



The miConverter 18-Module Power Chassis is a cost-effective mounting and powering solution for miConverter miniature media converters. This compact chassis is ideal for consolidating multiple media converters into a high-density, rack mountable form factor. It can be deployed in Service Provider, Enterprise and Government applications where fiber optic links are distributed from UTP switch equipment. The miConverter chassis is suitable for Fiber-to-the-Desk, Campus LAN/WAN fiber networks and hybrid copper/fiber networks.

The chassis holds up to eighteen miConverter 10/100, 10/100 Plus, Gx and GX/T copper to fiber media converter modules with barrel-style DC connectors. It provides centralized power for all installed modules, and eliminates the need for individual power supplies. It is available with a single universal AC, 24VDC or 48VDC internal power supply.

The chassis is less than 1.5U high, and two chassis can be installed in 3U of rack space. It can be mounted in a standard 19" equipment rack, or it can be mounted in a 23" rack using optional 23" rack mount brackets.

Each media converter within the chassis is secured in place and maintains a reliable power connection, even when data cables are under tension.

### KEY FEATURES

- Rack-mount 18-Module chassis for miConverter miniature media converter modules\*
- Provides high-density fiber distribution from UTP switches
- Two chassis can be mounted in 3U of rack space
- Standard 19" rack-mount dimensions allow space-saving and convenient installation
- Completely software independent with no installation of drivers required
- Media converters are secured in place. Reliable connection is maintained at all times
- Media converter modules are hot-swappable
- Available in universal AC, 24VDC and 48VDC models
- Commercial (0 to 50°C) and wide (-40 to 65°C) temperature ranges
- TAA, BAA and NDAA Compliant, and Made in the USA
- Peace-of-mind reliability backed by a lifetime warranty and free 24/7 technical support

\*18-Module Chassis does not support the miConverter S-Series modules.

## Fiber-to-the-Desk

In the upper left of this diagram, UTP from a core switch is converted to fiber with a miConverter 18-Module chassis of media converters.

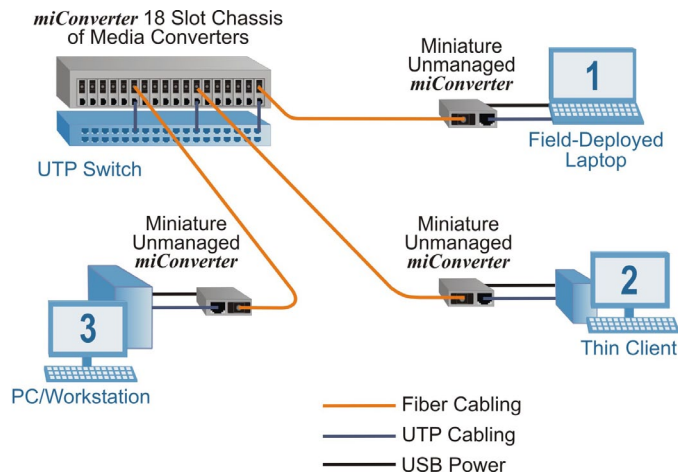

1. Fiber is distributed to a field-deployed laptop computer. A miniature miConverter media converter provides fiber connectivity to the laptop and draws power from the laptop's USB port (represented by the black line).
2. Fiber is distributed to a Thin Client, where a miniature miConverter converts the fiber to copper and provides connectivity to the Thin Client device that does not have a fiber port. The miConverter module is powered directly from a USB port on the Thin Client device, eliminating the need for an electrical outlet and saving energy costs.
3. Fiber is distributed to a PC or Workstation, where a miniature miConverter converts the fiber to a UTP cable that is connected to the workstation supporting a 10, 10/100 or 10/100/1000 copper connection. The miConverter module is powered directly from a USB port on the PC or Workstation.

## Hybrid Copper/Fiber Campus LAN

This application example illustrates an Ethernet Enterprise network with a star topology that provides multiple fiber links to remote buildings. In the upper left, three copper UTP links from a core switch are converted to three fiber links with a miConverter 18-Module chassis of media converter modules.

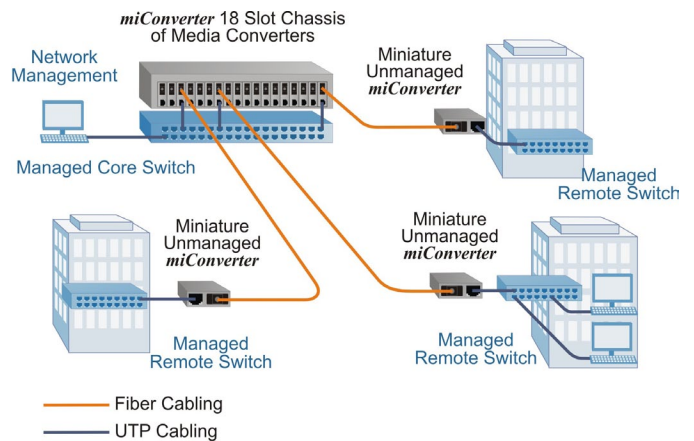

The fiber links run to remote buildings, where the fiber at each location is converted back to copper and distributed to end users at different buildings. Management is carried from the core switch across the fiber link to each switch located at the remote buildings. This provides centralized network management across the campus network.

# SPECIFICATIONS

| Chassis Type                       | AC Powered Chassis  | 24VDC Powered Chassis            | 48VDC Powered Chassis           |
|------------------------------------|---|----------------------------------|---------------------------------|
| Module Capacity                    | 18 modules with barrel-style power connectors   |                                  |                                 |
| Input Power Requirements (typical) | 100 to 240VAC, 50 to 60Hz<br>0.4A @ 120VAC  | +/- 18 to 36VDC,<br>2.0A @ 24VDC | +/- 36 to 60VDC<br>1.0A @ 48VDC |
| Input Power Connector              | IEC320  | 3-pin Terminal                   | 3-pin Terminal                  |
| Regulatory Compliances             | Safety: UL, cUL, CE, UKCA<br>EMI: FCC Class A<br>ACT: TAA, BAA, NDAA                                |                                  |                                 |
| Environmental                      | RoHS, WEEE, REACH   |                                  |                                 |
| Dimensions<br>W x D x H            | 17.5" x 9.5" x 2.5" (444.5 mm x 241.3 mm x 63.5 mm)   |                                  |                                 |
| Weight                             | 7.20 lbs. (3.27 kg)   |                                  |                                 |
| Temperature                        | Commercial Temp: 0 to 50°C<br>Wide Temp: -40 to 65°C, -20°C Cold Start<br>Storage Temp: -40 to 80°C |                                  |                                 |
| Humidity                           | 5 to 95% (non-condensing)   |                                  |                                 |
| Altitude                           | -100m to 4,000m   |                                  |                                 |
| MTBF (hrs)                         | 526,000   | 486,000                          | 1,081,000                       |
| Warranty                           | Lifetime warranty with 24/7/365 free Technical Support  |                                  |                                 |

## ORDERING INFORMATION

### Step 1: Choose a Base Part Number (xxxx-x-t)

| Model Number | Model Type  |
|--------------|---|
| 1020-1t      | 18-Module Chassis with AC Power Supply with IEC 320 Socket, 100 to 240VAC, 50/60Hz, 0.4A @ 120VAC       |
| 1025-1t      | 18-Module Chassis with 48 VDC Power Supply with Direct DC 3-Pin Terminal, +/- 36 to 60VDC, 1.0A @ 48VDC |
| 1026-1t      | 18-Module Chassis with 24 VDC Power Supply with Direct DC 3-Pin Terminal, +/- 18 to 36VDC, 2.0A @ 24VDC |

Chassis does not support miConverter modules with DC terminals power connectors or miConverter S-Series.  
19" rack mount brackets are included with chassis. Order 23" rack mount brackets separately.

### Step 2: Choose an Operating Temperature Option (xxxx-x-t)

|  |
|--|
| <leave blank> = Commercial temperature (0 to 50°C)       |
| W = Wide temperature (-40 to 60°C)                       |
| Contact Omnitron for other operating temperature models. |

## ACCESSORIES

| Model Number | Description  |
|--------------|--|
| 1092-0       | Spare L-Bracket for mounting media converter modules           |
| 1093-0       | Chassis blank panels. Quantity 1                               |
| 1093-1       | Chassis blank panels. Quantity 10                              |
| 8092-0       | Optional 23" rack mount brackets for 18-Module Powered Chassis |

© 2024 Omnitron Systems Technology, Inc. miConverter is a registered trademark of Omnitron Systems Technology, Inc. Trademarks are owned by their respective companies. Specifications subject to change without notice. All rights reserved.

