

GENERAL

This User Manual covers the following model numbers:

Fiber Type and Distance	Connector Types		Tx Lambda (nm)	Rx Lambda (nm)
	ST	SC		
MM/DF/5km	1120-0-x	1122-0-x	1310	1310
SM/DF/30km	1121-1-x	1123-1-x	1310	1310
SM/DF/60km	1121-2-x	1123-2-x	1310	1310
SM/DF/120km	-	1123-3-x	1550	1550
MM/SF/5km	-	1130-0-x	1310	1550
MM/SF/5km	-	1131-0-x	1550	1310
SM/SF/20km	-	1130-1-x	1310	1550
SM/SF/20km	-	1131-1-x	1550	1310
SM/SF/40km	-	1130-2-x	1310	1550
SM/SF/40km	-	1131-2-x	1550	1310
SM/SF/60km	-	1130-3-x	1310	1550
SM/SF/60km	-	1131-3-x	1550	1310

Model numbers are followed by -x, where -x indicates the specific type of power option. See the data sheet for more information.

DESCRIPTION

The miConverter 10/100 Plus is a 10/100BASE-T copper to 100BASE-FX fiber media converter. The copper port can automatically detect the speed, duplex mode and crossover mode of the connected device, or it can be manually configured via DIP-switches.

The 100BASE-FX fiber port operates in Full-Duplex mode and supports single-mode or multimode fiber with ST or SC fiber connectors. Single-mode models feature Bi-Directional fiber and support distances of up to 40km. The various fiber models options are described in the table on the first page.

Link Modes include Link Segment, Link Propagate, Remote Fault Detection and Symmetrical Fault Detection. The link mode assist in the identification and isolation of link failures.

WARNING!
Before inserting the Power Adapter, verify that the power on the unit is appropriate for your AC line voltage source.

POWER MODES

AC power adapter is available in US, Universal and Country/Region specific models. Country/Region specific models feature optional interchangeable connectors, allowing for compatibility with electrical outlet types found around the world.

This product should only be used with Omnitron Supplied Power Unit.

To power the module using the USB cable, connect the USB Standard Type A connector to a USB port on the

computer. Then connect the connector at the other end of the cable (barrel connector) to the connector on the back of the miConverter. Confirm that the module has powered up properly by checking the power status LED located on the top of the module.

To power the module using the AC/DC adapter, connect the AC/DC adapter to the AC outlet. Then connect the barrel connector at the end of the cable to the back of the miConverter. Confirm that the module has powered up properly by checking the power status LED located on the top of the module.

INSTALLATION PROCEDURE

The miConverter 10/100 can be quick-mounted using the included Velcro® strips, or permanently mounted using the optional wall-mounting kit (P/N 4381).

Configure the miConverter 10/100 Plus with the appropriate DIP-switch settings. The factory default configuration for the UTP copper port is "AN" Auto-negotiation and the Link Mode is "LS" Link Segment.

Attach the RJ-45 port of the miConverter 10/100 to a 10BASE-T or 100BASE-TX PoE capable Ethernet device, via a category 5 or better cable.

Attach the fiber port of the miConverter 10/100 to a 100BASE-X Fast Ethernet device, via a fiber cable of appropriate mode and type.

When connecting the dual-fiber models, the miConverter transmitter (Tx) must attach to the receiver side of its link partner; the receiver (Rx) must attach to the transmitter.

When using single-fiber (SF) media converter models, the Tx wavelength on one end has to match the Rx wavelength on the other. Based on this guideline, the SF media converter models must be used in pairs, such as the 1130-1 matched with the 1131-1.

DIP-SWITCH SETTINGS

The miConverter has four DIP-switches on the side of the module. The DIP-switches allow the RJ-45 port to be configured for auto-negotiation or manual operation. The DIP-switches also configure link modes which propagates link failures.

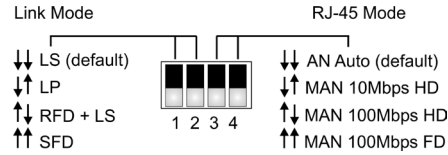

RJ-45 Mode Selection

SW3	SW4	RJ-45 Mode of Operation
Down	Down	RJ-45 port set to auto-negotiation. The following modes are advertised. 100F, 100H, 10F, 10H
Down	Up	Manual Operation - 10H
Up	Down	Manual Operation - 100H
Up	Up	Manual Operation - 100F

Link Mode Selection

The miConverter 10/100 Plus can be configured for several miConverter Link Modes.

SW1	SW2	Link Mode of Operation
Down	Down	Link Segment (LS)
Down	Up	Link Propagate (LP)
Up	Down	Remote Fault Detect + Link Segment (RFD+LS)
Up	Up	Symmetrical Fault Detect (SFD)

Link Segment (LS)

"LS" (factory default) generates and detects a link signal at each point in the network. Utilizing this configuration, a loss of a receive link signal will only affect the port detecting the loss of signal. All the other ports will continue to generate a link signal. Figure A below indicates the normal operation of the system without faults. Figure B below indicates a loss of a receive link on the fiber optic port, the RJ-45 port continues to maintain its link.

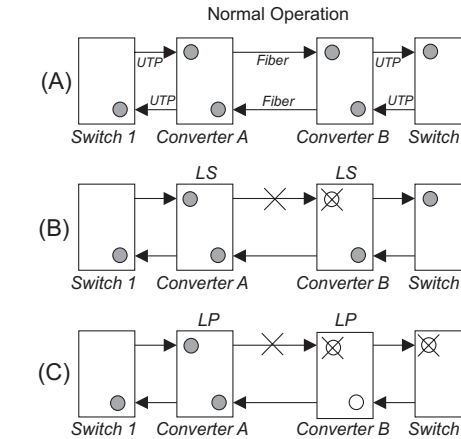

Link Propagate (LP)

"LP" generates (transmits) a link signal only when a link signal is detected. Utilizing this configuration, a loss of a receive link signal will continue to 'propagate' through to the next port in the network. In Figure C, a loss of a receive link on the fiber optic port causes the RJ-45 port

to drop its link due to the propagated fiber optic link state. This setting allows the loss of a link to be detected by SNMP or other managed network devices to which the module is connected.

NOTE: Only the first loss of a receive link detected by the module turns off the other port's transmit link. An additional loss of a receive link on the other port has no effect on the module. The module returns to normal operation when the first loss of a receive link is restored.

Remote Fault Detect + Link Segment (RFD + LS)

"RFD+LS" generates a link signal only when a link signal is detected. However, instead of propagating the fault forward, the loss of link is looped back. In Figure D on the next page, a loss of a received link state is looped back causing the port to stop transmitted the link state. Because the other unit is configured for Link Propagate, the RJ-45 port will drop its link due to the propagated fiber optic link state.

NOTE: It is not permitted to set both Converter A and B to RFD at the same time; a deadly embrace will occur.

Symmetrical Fault Detect (SFD)

"SFD" generates a Link Loss signal on all ports on both media converters when a loss of link signal is detected by one of the ports. In Figure E on the next page, the pattern of LEDs gives an indication of the failure point.

NOTE: Both media converters must be configured with the SFD Link Mode. The SFD function is only supported by Omnitron Systems equipment.

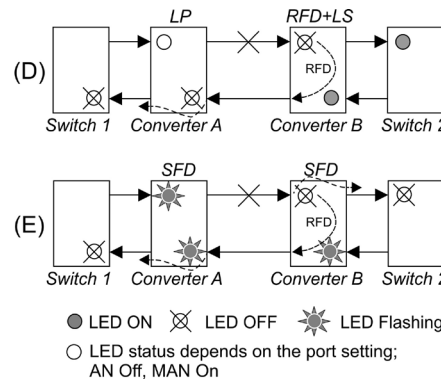

LED INDICATORS

LED	Color	Description
Power "Pwr"	Amber	Off: No Power On: Power applied
Fiber Link "F/O"	Green	Off: No fiber link On: Fiber link Blinking (10Hz): Data activity Blinking (5Hz): SFD Error
RJ-45 Link "UTP"	Green	Off: No RJ-45 link On: RJ-45 link Blinking (10Hz): Data activity Blinking (5Hz): SFD Error
RJ-45 Speed "100"	Green	Off: Linked at 10M when UTP LED is ON On: Linked at 100M when UTP LED is ON
RJ-45 Duplex "FDX"	Green	Off: Half-Duplex On: Full-Duplex

SPECIFICATIONS

Standard Compliances	IEEE 802.3	
Regulatory Compliances	Safety: UL, cUL, CE, UKCA EMI: FCC Class A ACT: TAA, BAA, NDAA	
Environmental	RoHS, REACH, WEEE	
Frame Size	Up to 1,536 bytes	
Port Types	Copper: 10/100BASE-T (RJ-45) Fiber: 100BASE-X (ST, SC)	
Cable Types	Copper: EIA/TIA 568A/B, Cat 5 UTP and higher Fiber: Multimode: 50/125µm, 62.5/125µm Single-mode: 9/125µm	
AC Power Requirements	AC Adapter: 100 - 240VAC/50 - 60Hz 0.03A @ 120VAC (max)	
DC Power Requirements	DC Input: 5.0 to 12.0VDC (AC Adapter) 0.5A @ 5VDC, 0.28A @ 9VDC 2.5mm Barrel Connector	
Dimensions W x D x H	Standalone: 1.71" x 4.10" x 0.84" (43.4 mm x 104.1 mm x 21.3 mm)	
Weight	Module: 4 oz. (113.4 grams) With AC adapter: 12 oz. (340.2 grams)	
Temperature	Commercial: 0 to 50°C Wide: -40 to 60°C	
Humidity	5 to 95% (non-condensing)	
Altitude	-100m to 4,000m	
MTBF (hrs)	Module: 1,160,000 With US AC Adapter: 206,000	
Warranty	Lifetime warranty with 24/7/365 free Technical Support	

MECHANICAL

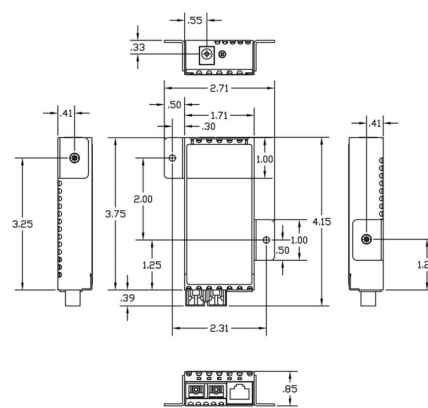

General and Copyright Notice

This publication is protected by U.S. and international copyright laws. All rights reserved. The whole or any part of this publication may not be reproduced, stored in a retrieval system, translated, transcribed, or transmitted, in any form, or by any means, manual, electric, electronic, electromagnetic, mechanical, chemical, optical or otherwise, without prior explicit written permission of Omnitron Systems Technology, Inc.

The following trademarks are owned by Omnitron Systems Technology, Inc.: FlexPoint™, FlexSwitch™, iConverter®, miConverter®, NetOutlook®, OmniLight®, OmniConverter®, RuggedNet®, Omnitron Systems Technology, Inc.™, OST™ and the Omnitron logo.

All other company or product names may be trademarks of their respective owners.

The information contained in this publication is subject to change without notice. Omnitron Systems Technology, Inc. is not responsible for any inadvertent errors.

Warranty

This product is warranted to the original purchaser (Buyer) against defects in material and workmanship for a period of two (2) years from the date of shipment. A lifetime warranty may be obtained by the original purchaser by registering this product at www.omnitron-systems.com/support within ninety (90) days from the date of shipment. During the warranty period, Omnitron will, at its option, repair or replace a product which is proven to be defective with the same product or with a product with at least the same functionality.

For warranty service, the product must be sent to an Omnitron designated facility, at Buyer's expense. Omnitron will pay the shipping charge to return the product to Buyer's designated US address using Omnitron's standard shipping method.

Limitation of Warranty

The foregoing warranty shall not apply to product malfunctions resulting from improper or inadequate use and/or maintenance of the equipment by Buyer, Buyer-supplied equipment, Buyer-supplied interfacing, unauthorized modifications or tampering with equipment (including removal of equipment cover by personnel not specifically authorized and certified by Omnitron), or misuse, or operating outside the environmental specification of the product (including but not limited to voltage, ambient temperature, radiation, unusual dust, etc.), or improper site preparation or maintenance.

No other warranty is expressed or implied. Omnitron specifically disclaims the implied warranties of merchantability and fitness for any particular purpose.

The remedies provided herein are the Buyer's sole and exclusive remedies. Omnitron shall not be liable for any direct, indirect, special, incidental, or consequential damages, whether based on contract, tort, or any legal theory.

Environmental Notices

The equipment covered by this manual must be disposed of or recycled in accordance with the Waste Electrical and Electronic Equipment Directive (WEEE Directive) of the European Community directive 2012/19/EU on waste electrical and electronic equipment (WEEE) which, together with the RoHS Directive 2015/863/EU, for electrical and electronic equipment sold in the EU after July 2019. Such disposal must follow national legislation for IT and Telecommunication equipment in accordance with the WEEE directive: (a) Do not dispose waste equipment with unsorted municipal and household waste. (b) Collect equipment waste separately. (c) Return equipment using collection method agreed with Omnitron.

The equipment is marked with the WEEE symbol shown to indicate that it must be collected separately from other types of waste. In case of small items the symbol may be printed only on the packaging or in the user manual. If you have questions regarding the correct disposal of equipment go to www.omnitron-systems.com/support or e-mail to Omnitron at intinfo@omnitron-systems.com.



Technical Support:

Phone: (949) 250-6510
Fax: (949) 250-6514
Address: Omnitron Systems Technology
38 Tesla
Irvine, CA 92618 USA
E-mail: support@omnitron-systems.com
URL: http://www.omnitron-systems.com