

### **iConverter® xFF** **SFP to SFP Protocol-Transparent Fiber Converter**

The iConverter xFF is a protocol-transparent media converter, and is available as a compact, unmanaged standalone unit or a managed chassis plug-in module. The iConverter xFF is an Optical-Electrical-Optical (OEO) device, and provides reliable and cost-effective conversion between different wavelengths, multimode and single-mode, and dual and single-fiber.

The iConverter xFF operates as a protocol and rate-transparent device, supporting Small Form Pluggable (SFP) transceivers with constant data rates from 1Mbps to 8.50Gbps. The xFF supports a variety of network applications, including T1/E1, T3/E3, Ethernet, Fast Ethernet, Gigabit Ethernet, SONET (OC-3/12/48), SDH (STM-1/4/16), 1x/2x/4x/8x Fibre Channel and Common Public Radio Interface (CPRI).

The iConverter xFF supports multimode and single-mode dual fiber; and single-mode single-fiber SFP transceivers. SFPs allow adaptability to different fiber types, distances and wavelengths, providing maximum flexibility across a variety of network architectures and topologies. The xFF media converter can utilize a variety of SFPs for different wavelengths and distances, reducing costs and simplifying inventories.

SFP transceivers enable the xFF to operate as a Coarse Wave Division Multiplexing (CWDM) or Dense Wave Division Multiplexing (DWDM) transponder, which converts an optical signal from legacy fiber equipment to a specific CWDM/DWDM wavelength. Wave division technology increases the bandwidth capacity of the fiber infrastructure by overlaying multiple signals, each using a different wavelength, over an existing fiber link.

There is no configuration required with the plug-and-play iConverter xFF. Connect the fiber cables to the appropriate interface and the installation is complete.

The xFF features user-selectable Link Propagate and Remote Fault Detection modes to facilitate quick fault detection, isolation and reporting.

The hot-swappable, plug-in module can be mounted in a 19 or 5-Module chassis with AC and DC power supplies. It can also be mounted in a 2-Module AC or DC powered chassis, or in a 1-Module chassis with AC or DC power input.

The standalone iConverter xFF is an unmanaged wall-mount unit. The wall-mount models are DC powered and are available with an external AC to DC power adapter, or a terminal connector for DC power.



SFPs not included

### **KEY FEATURES**

- SFP to SFP protocol-transparent fiber converter
- Supports Ethernet, Fast Ethernet and Gigabit Ethernet
- Supports SONET (OC-3/12/48) and SDH (STM-1/4/16)
- Supports 1x/2x/4x/8x Fibre Channel
- Supports Common Public Radio Interface (CPRI) line rates up to 6.144Gbps
- Compatible with T1/E1, DS3/T3/E3, serial multiplexers and media converters from Omnitron
- Supports SFP Digital Diagnostic Monitoring Interface (DDMI) bus
- Provides multimode to single-mode and dual to single-fiber media conversion
- Provides wavelength conversion for CWDM/DWDM applications
- User-selectable link fault detection modes facilitate quick fault detection, isolation and reporting
- Automatic Link Recovery
- LED displays for immediate visual status of each port
- Management of the plug-in module is available with the addition of a management module to the chassis
- SNMP management via NetOutlook® provides real-time module status information and trap notification of plug-in module
- Commercial (0 to 50°C), wide (-40 to 60°C) and extended (-40 to 75°C) temperature ranges
- TAA, BAA and NDAA compliant, and Made in the USA
- Lifetime Warranty and free 24/7 Technical Support

# APPLICATIONS

## Multimode to Single-mode Conversion

Networks often require conversion from multimode to single-mode fiber, which supports longer distances. In this application, two Ethernet switches equipped with

multimode fiber ports are connected utilizing a pair of fiber-to-fiber converters which convert the multimode fiber to single-mode and enable network connectivity across the distance between the switches.

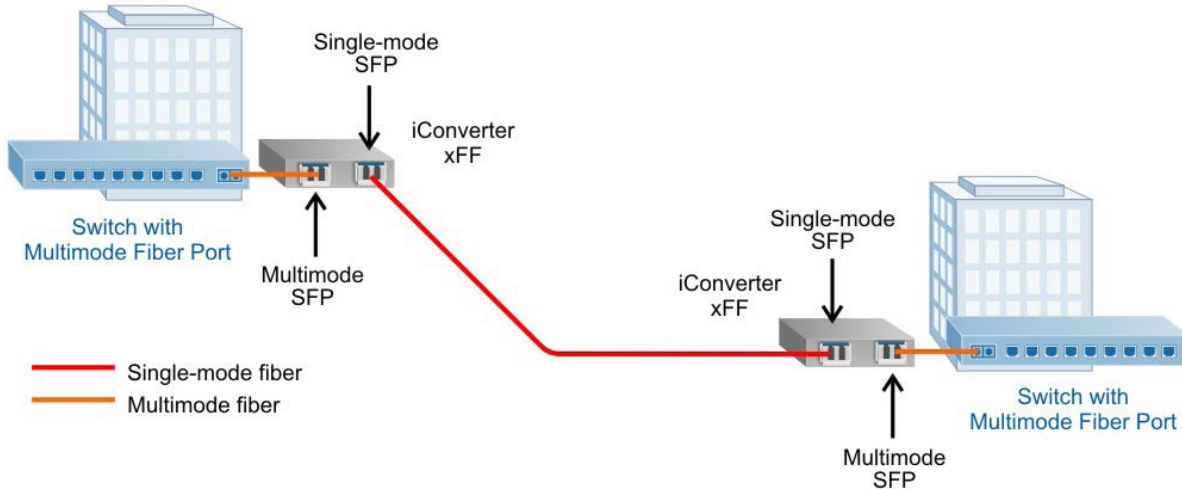

## CWDM Transponder

Fiber optic communications equipment with fixed fiber interfaces (ST, SC or LC connectors) operating over legacy wavelengths (850nm, 1310nm, 1550nm) must be converted to CWDM wavelengths using a media converter configured as a transponder.

The iConverter xFF is SFP to SFP protocol-transparent fiber converter and transponder, designed to provide conversion between different wavelengths, multimode and single-mode, dual fiber and single-fiber.

In this example, an Ethernet switch with a fixed fiber uplink port needs to be connected to an iConverter CWDM/M Multiplexer. An iConverter xFF transponder module is used

to convert the fixed fiber wavelength from the Ethernet switch to a specific CWDM wavelength required by the CWDM/M Multiplexer.

Two SFP transceivers are required in this application. The left side of the transponder uses a 1310nm standard SFP transceiver, while the right side of the transponder uses a 1530nm CWDM SFP transceiver. The CWDM SFP installed in the transponder is connected to a channel port on the iConverter CWDM/X Multiplexer.

The iConverter xFF converts the legacy 1310nm wavelength to CWDM 1530nm wavelength allowing the Ethernet switch to be connected to the Multiplexer.

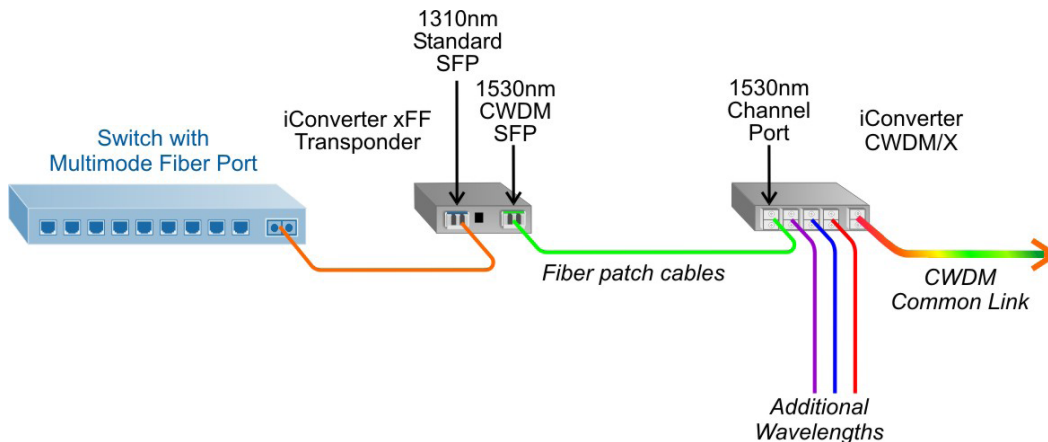

# SPECIFICATIONS

<b>Description</b>	<i>iConverter</i> xFF SFP to SFP Protocol-Transparent Fiber Converter	
<b>Standard Compliances</b>	Protocol Transparent up to 8.50Gbps: Ethernet (100BASE-X, 1000BASE-X) SONET (OC-3, OC-12, OC-48), SDH (STM-1, STM-4, STM-16) Fibre Channel (1x, 2x, 4x, 8x), CPRI line rates (up to 6.144Gbps)	
<b>Compatible Applications</b>	T1/E1, DS3/T3/E3, RS232, RS422, RS485, X.21	
<b>Regulatory Compliances</b>	Safety: EMI: ACT:	UL, cUL, CE, UKCA FCC Class A TAA, BAA, NDA
<b>Frame Size</b>	Unlimited	
<b>Port Types</b>	Fiber:	Protocol Transparent (SFP)
<b>Cable Types</b>	Fiber:	Multimode: 50/125µm, 62.5/125µm Single-mode: 9/125µm
<b>Humidity</b>	5 to 95% (non-condensing)	
<b>Altitude</b>	-100m to 4,000m	
<b>MTBF (hrs)</b>	Plug-in: Standalone w/o Adapter: Standalone w/ US Adapter: Standalone w/ Uni Adapter:	1,300,000 1,200,000 250,000 100,000
<b>Warranty</b>	Lifetime warranty with 24/7/365 free Technical Support	

<b>AC Power Requirements</b>	AC Adapter:	100 - 240VAC/50 - 60Hz 0.05A @ 120VAC
<b>DC Power Requirements</b>	DC Input: (Backplane)	3.3VDC, 0.5A @ 3.3VDC
	DC Input: (Terminal Block)	5 - 32VDC, 0.3A @ 9VDC (1.0A max) 2-Pin Terminal (non-isolated)
	DC Input: (AC Adapter)	5 - 32VDC, 0.3A @ 9VDC (1.0A max) 2.5mm Barrel Connector
<b>Dimensions (W x D x H)</b>	Plug-in:	0.85" x 4.5" x 2.8" 21.6 mm x 114.3 mm x 71.1 mm
	Standalone:	3.8" x 4.8" x 1.0" 96.5 mm x 121.9 mm x 25.4 mm
<b>Weight</b>	Plug-in:	8 oz.; 226.8 grams
	Standalone w/o Adapter:	1.0 lb.; 453.6 grams
	Standalone w Adapter:	1.5 lbs.; 680.4 grams
<b>Temperature</b>	Commercial:	0 to 50°C
	Wide:	-40 to 60°C
	Extended:	-40 to 75°C
	Storage:	-40 to 80°C

# ORDERING INFORMATION

## Step 1: Choose a Base Part Number (8699-0-pt)

Model Number	Description
8699-0-pt	SFP to SFP Protocol-Transparent Fiber Converter

## Step 2: Choose a Power Option (8699-0-pt)

<leave blank> = Plug-in module
<b>D</b> = Barrel Connector and AC/DC Power Adapter 100-240VAC, 50-60Hz, with US power cord, with integrated mounting brackets
<b>E</b> = Barrel Connector and Universal AC/DC Adapter, 100 - 240 VAC, 50-60Hz, No Power Cord, with integrated mounting brackets
<b>F</b> = Direct DC input, 2 pin terminal connector, no AC/DC power adapter, with integrated mounting brackets
<b>J</b> = Barrel Connector and JPN PSE AC/DC Adapter, 100 - 240 VAC, 50-60Hz, No Power Cord, with integrated mounting brackets

## Step 3: Choose an Operating Temperature Range (8699-0-pt)

<leave blank> = Commercial temperature (0 to 50°C)
<b>W</b> = Wide temperature (-40 to 60°C)
<b>Z</b> = Extended temperature (-40 to 75°C)

© 2025 Omnitron Systems Technology, Inc. All rights reserved. *iConverter* and *NetOutlook* are registered trademarks of Omnitron Systems Technology, Inc. Trademarks are owned by their respective companies. Specifications are subject to change without notice.

