

iConverter GX/T Dual Fiber Modules				
Fiber Type	Distance	Connector Type		
		SC	MT-RJ	LC
MM	220m / 550m ¹	8522-0	8524-0	8526-0
SM	12 km	8523-1	8525-1	8527-1
SM	34 km	8523-2	-	8527-2
SM	80 km	8523-3	-	8527-3

iConverter GX/T Single-Fiber Modules			
Fiber / Connector Type	Distance	Tx: 1310nm, Rx: 1550nm	Tx: 1550nm, Rx: 1310nm
SM / SC	20 km	8530-1	8531-1
SM / SC	40 km	8530-2	8531-2

For wide temperature (-40 to 60° C), add a "W" to the end of the model number. Consult factory for extended temperature (-40 to 75° C) models.

LINK MODES

In order to accommodate different user needs, the GX/T supports five different linking modes (see Fig. 2).

In Link Segment (LS), a port transmits a Link signal independently of any received Link at any other port. For example, the UTP transmits a Link regardless of the fiber receiving a Link [Fig. 2(a) & (b)].

In Link Propagate (LP), a port transmits a Link signal only when receiving a Link at its other port. For example, the UTP transmits a Link only when receiving a Link at the fiber port [Fig. 2(c)].

In Remote Fault Detection + Link Segment (RFD+LS), the fiber port transmits a Link signal only when receiving a Link at the fiber port. As a result, fiber faults (no Link received at the fiber) are looped-back and can be reported to the network core [Fig. 2(d)].

In Remote Fault Detection + Link Propagate (RFD+LP), the UTP port transmits a Link signal only when receiving a Link at the fiber port. The fiber port transmits a Link signal only when receiving Link signals at both the fiber port and the UTP port. As a result, fiber faults (no Link received at the fiber) are propagated forward and looped back for fault reporting at both the network core and the customer location [Fig. 2(e)].

NOTE: Connecting two converters with both set to RFD mode is not supported and will cause a "deadly embrace" lockup.

OVERVIEW

The iConverter GX/T provides 10/100/1000BASE-T UTP to 1000BASE-X Fiber conversion as well as rate conversion between 10BASE-T, 100BASE-TX, 1000BASE-T and 1000BASE-SX/LX. Models are available for multimode (MM) and single-mode (SM) dual fiber, and single-mode single-fiber (SF).

The GX/T UTP port supports Half-Duplex and Full-Duplex modes and features an automatic crossover mode for easy attachment to hubs, switches and workstations.

The GX/T can be used as a standard two-port UTP to fiber converter. It can also use its two additional 10/100 backplane ports to connect to adjacent modules and accommodate flexible network configurations. The iConverter 19-Module, 5-Module or 2-Module Chassis have backplanes that facilitate connectivity between adjacent modules.

The GX/T can be used in a managed or unmanaged application. When managed, it must be installed in a chassis with an iConverter Network Management Module (NMM), GX/TM or 10/100M.

ADVANCED FEATURES

The GX/T features Port VLAN and Tag VLAN, which allow complete control of traffic flow between the front-plane UTP port, the fiber port and the chassis backplane ports. The GX/T also features Port Access Control, which facilitates enabling and disabling of individual ports. It also supports reporting of MIB statistics.

NOTE: Using the advanced features listed above requires the use of the Network Management Module (NMM) and the NetOutlook™ Management Software (or third-party SNMP management software) or Telnet.

For more information on using and configuring these advanced features, please refer to the NetOutlook Management Software user manual.

PORT STRUCTURE

Using a 4-port switch design, the GX/T features two front-plane ports (1000Mbps fiber Port 1 and a 10/100/1000 UTP Port 2) and two 10/100 Ethernet backplane ports (A and B) that can connect to adjacent modules within the same chassis.

When the GX/T backplane A and B ports are enabled (using "BPAEN" and "BPBEN" DIP-Switches), they connect via the chassis backplane to the slots on the left and right sides of the GX/T module. When another switch-based module with backplane port connections (such as a second GX/T or an NMM) is installed in an adjacent slot, it can be connected via the backplane to the GX/T to facilitate a multi-module configuration.

GX/T Application Example:

Fig. 1 depicts a chassis with three modules plugged into three adjacent backplane slots (beginning with an odd numbered slot). The adjacent slots are connected via the backplane using the A and B 10/100 links. In this example, the GX/T in the center slot connects to the slot on its left using the A link and the slot on its right using the B link.

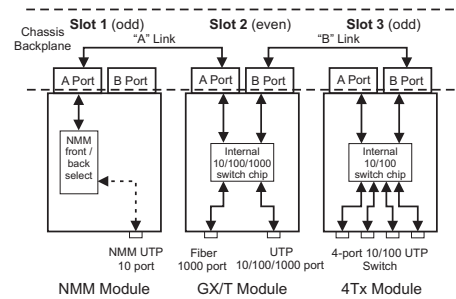

Fig. 1 In-Band Managed GX/T Application

In this example, the module on the left is a Network Management Module (NMM), connecting via its A backplane port to the GX/T, facilitating In-Band management (via the fiber uplink). The module on the right is a 4-port 10/100 switch module, connecting via its B link port to the GX/T, facilitating a 1-Port GX/T and a 4-Port 10/100 Ethernet switch with a fiber uplink configuration. This 3-module configuration provides an effective 10/100/1000 UTP to 4-Port 10/100 managed switch with a gigabit fiber uplink configuration.

This example shows how the GX/T can be used either as a traditional managed or unmanaged media converter, or to create flexible and effective network switch configurations.

For more information about individual chassis A and B backplane links, please refer to the specific chassis user manual.

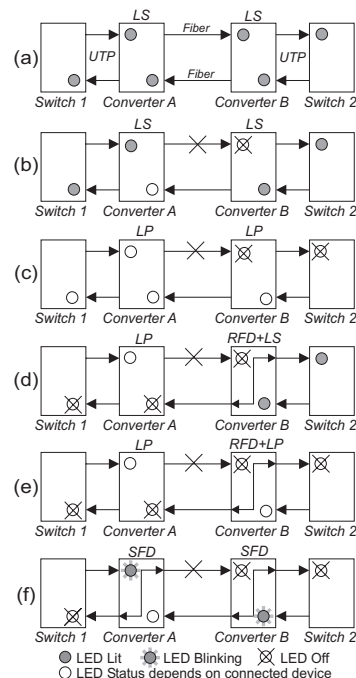

Fig. 2 GX/T Link Modes

In Symmetrical Fault Detection (SFD), the UTP port transmits a Link signal only when receiving a Link at the fiber port. The fiber port transmits a Link signal only when receiving a Link signal at both the fiber port and the UTP port. As a result, fiber faults (no Link received at the fiber) are looped back and can be reported to the network core. In addition, connecting two back-to-back converters which are both set to SFD facilitates dual-loop-back, where fiber faults are reported to both ends of the network. A blinking fiber link LED on a converter indicates a fault of the transmit fiber or UTP cables of that converter [Fig. 3(f)].

NOTE: Converters in SFD mode must be deployed in pairs.

Fiber set to Auto-Negotiation Mode

When the Fiber is set to Auto-Negotiation Mode, the device receiving the fault acts as if it is in RFD mode. Link Segment, Link Propagate and Symmetrical Fault Detection modes operate in the same manner (refer to Fig. 2(d), (e) and (f)).

NOTE: "Remote Fault Detection" (RFD) is not a valid mode when the fiber is set to Auto-Negotiation. The user should select LS, LP or SFD instead.

DIP-SWITCH SETTINGS

Front Panel DIP-Switch Settings

- Link Segment = LS LP = Link Propagate
- Off RFD = Remote Fault Detect
- Off SFD = Symmetrical Fault Detect
- Straight-Through = X = Crossover

Fig. 3 Front Panel DIP-Switches

Link Segment/Link Propagate "LS/LP" DIP-Switch

This DIP-Switch controls the Link Propagate or Link Segment modes. When the DIP-Switch is in the "LS" position (factory setting), Link Segment mode is enabled. In the "LP" position, Link Propagate mode is enabled.

Remote Fault Detection "RFD" DIP-Switch

When in the "RFD" position, the Remote Fault Detection mode is enabled. Set the board-mounted Port 1 DIP-Switch to Manual Mode "MAN" for this feature.

NOTE: Connecting two converters with both set to RFD mode is not supported and will cause a "deadly embrace" lockup.

Symmetrical Fault Detection "SFD" DIP-Switch

When this DIP-Switch is in the "SFD" position, the Symmetrical Fault Detection mode is enabled. When in the "Off" position (factory setting), the Symmetrical Fault Detection mode is disabled.

NOTE: Converters in SFD mode must be deployed in pairs.

RJ-45 Manual Crossover "= / X" DIP-Switch

When the board-mounted Manual Crossover Enable DIP-Switch is set to "MANX," the front panel RJ-45 Manual Crossover Switch is enabled. When connecting the UTP to a hub or switch, set the front panel switch to Straight-Through "=" (factory setting). When connecting to a workstation, set it to Crossover "X." Only use this setting with 10T or 100Tx mode.

BOARD MOUNTED DIP-SWITCHES

	Off	ON	
P1 Auto Negotiate =	AN	BPAEN = Backplane "A" Enabled	
P2 Auto Negotiate =	AN	BPBEN = Backplane "B" Enabled	
P2 Full Duplex =	FD	MAN = P1 Manual FO	
UTP 100Mbps =	100	MAN = P2 Manual UTP	
UTP 1000Mbps =	1000	HD = P2 Half Duplex	
Auto Crossover =	AX	10 = UTP 10Mbps	
		10-100 = UTP 10/100Mbps	
		MANX = Manual Crossover	

Fig. 4 Board Mounted DIP-Switches

Backplane A Enable DIP-Switch (BPAEN)

When the "BPAEN" DIP-Switch is in the "ON" position (right), the *iConverter* GX/T module A backplane Ethernet port is enabled. This port allows connectivity to an adjacent module. When the "BPAEN" DIP-Switch is in the "Off" position (left, factory setting), the A port is isolated from the backplane.

Backplane B Enable "BPBEN" DIP-Switch

When the Backplane B Enable "BPBEN" DIP-Switch is in the "ON" position (right), the *iConverter* GX/T module B backplane Ethernet port is enabled. This port allows connectivity to an adjacent module. When the "BPBEN" DIP-Switch is in the "Off" position (left, factory setting), the B port is isolated from the backplane.

Fiber Auto/Manual P1 "AN/MAN" DIP-Switch

Setting this DIP-Switch to P1 Auto-Negotiate "AN" (factory setting) enables the Fiber Port to determine duplex mode automatically. If the connected device cannot provide the proper signal to indicate its own mode of operation, this DIP-Switch should be set to P1 Manual "MAN." This feature allows connections with devices that do not auto-negotiate properly.

Page 9

NOTE: When the fiber port is in Manual Mode, sometimes a link-up will not occur with other devices. Both devices must be set to the same mode (either Manual or Auto-Negotiate) for the link-up to occur.

UTP Auto/Manual P2 "AN/MAN" DIP-Switch

Setting the P2 Auto/Manual Negotiate DIP-Switch to Auto-Negotiate "AN" (factory setting) enables the UTP port to determine the speed and duplex mode automatically. If the connected device cannot provide the proper signal to indicate its own mode of operation, this DIP-Switch should be set to P2 Manual "MAN." This feature allows connections with devices that do not auto-negotiate properly.

NOTE: Attaching an auto-negotiating UTP port to a non auto-negotiating (manual/forced/hard-coded) UTP port may result in an unpredictable port setting with excessive collisions and poor link performance. When operating in manual mode, both mating ports MUST be set manually to the same speed and duplex mode.

Gigabit devices typically function only in Auto-Negotiate Mode. 1000 Manual Mode is not a valid mode and will result in an undefined response. Use Manual mode only when selecting the 10 or 100 mode.

UTP Full/Half-Duplex P2 "FD/HD" DIP-Switch

When the UTP P2 Auto/Manual DIP-Switch (described above) is in the P2 Manual "MAN" position, the UTP P2 Full/Half Duplex "FD/HD" DIP-Switch selects the duplex mode for the UTP port. When set to Full-Duplex "FD" (factory setting), the UTP port operates in Full-Duplex mode. When P2 is set to Half-Duplex "HD," the UTP port operates in Half-Duplex mode.

Page 10

UTP 10/100 P2 "10/100" DIP-Switch

When the UTP P2 Auto/Manual DIP-Switch is in the Auto-Negotiate "AN" position and the "10-100/1000" DIP-Switch (described below) is set to "10-100," the "10/100" DIP-Switch determines the highest speed of the UTP P2 port in the following manner:

When the "10/100" DIP-Switch is set to the "100" position, P2 operates at 100Mbps or less, depending on the speed of the connected device.

When the "10/100" DIP-Switch is set to the "10" position, P2 operates only at 10Mbps.

When the UTP P2 Auto/Manual DIP-Switch is in the Manual "MAN" position and the UTP "10-100/1000" DIP-Switch (described below) is set to "10-100," the "10/100" DIP-Switch determines the speed of the UTP P2 port. When set to "100" (factory setting), the UTP port will operate at 100Mbps. When set to "10," the UTP port will operate at 10Mbps.

UTP 10-100/1000 P2 "10-100/1000" DIP-Switch

When the P2 "AN/MAN" DIP-Switch is set to the Auto-Negotiate "AN" position, the "10-100/1000" DIP-Switch operates in the following manner:

When set to "1000," P2 operates at 1000Mbps or less, depending on the speed of the connected device. When set to the "10-100" position, the speed is selected by the UTP "10/100" DIP-Switch.

When the P2 "AN/MAN" DIP-Switch is set to Manual "MAN" mode, the "10-100/1000" DIP-Switch must be set to the "10-100" position and the speed is selected by the "10/100" DIP-Switch.

Page 11

NOTE: Setting the "10-100/1000" DIP-Switch to the "1000" position when in Manual mode is not permitted (per the IEEE 802.3 standard) and will result in unpredictable port behavior.

Auto/Manual Crossover Enable P2 "AX/MANX" DIP-Switch

When the Manual/Auto Crossover Enable DIP-Switch is set to Auto Crossover "AX" (factory default), the front panel crossover switch is disabled and the RJ-45 crossover is selected automatically. When it is set to Manual Crossover "MANX," the front panel RJ-45 Manual Crossover DIP-Switch is enabled to allow a manual setting in either Crossover or Straight-Through connection.

Page 12

LED INDICATORS

LED	Color	Description
Pwr:	Yellow	On--Power / Blink--test
Fiber FDX:	Green	On--Full-Duplex detected
Lk/Act	Green	On--Link / Blink--activity
AN:	Green	On--UTP Auto-Neg. enabled
10:	Green	On--10 Mbps link / Blink-activity
100:	Green	On--100 Mbps link / Blink-activity
1000:	Green	On--1000 Mbps link / Blink-activity
UTP FDX:	Green	On--Full-Duplex detected

Mounting and Cable Attachment

iConverter modules are hot-swappable and can be installed into any chassis in the *iConverter* family.

- Carefully slide the *iConverter* module into the installation slot, aligning the module with the installation guides. **NOTE:** Ensure that the module is firmly seated against the backplane.
- Secure the module by securing the panel fastener screw (attached to module) to the chassis front.
- Attach the UTP port via a category 5 cable to a 1000BASE-T, 100BASE-TX or 10BASE-T Ethernet device.
- Attach the fiber port via an appropriate multimode or single-mode fiber cable to a 1000BASE-X Ethernet device. The *iConverter* transmit (Tx) must attach to the receive side on other device; the receive (Rx) must attach to the transmit.
- When using single-fiber (SF) media converter models, the Tx wavelength on one end has to match the Rx wavelength on the other. Note that based on this guideline, the SF media converter models must be used in pairs, such as the 8530-1 matched with the

Model Type	GX/T
Protocols	10BASE-T, 100BASE-TX, 1000BASE-T, 1000BASE-SX/LX
UTP Connectors	RJ-45
Fiber Connectors	SC, MT-RJ, LC, Single-Fiber SC
Controls	BP Enable, X-Over, LS/LP, RFD, SFD, UTP Auto/Man, 10/100/1000, UTP FDX/HDX, F/O Auto/Man
LED Displays	Power, FO link, UTP link, Auto, FDX/HDX, 10/100/1000
Dimensions	W:0.85" x D:4.5" x H:2.8"
Weight	8 oz.
Compliance	UL, CE, FCC Class A
Power Requirement	1.4A @ 3.3VDC (typical)
Temperature	Standard: 0 to 50° C Wide: -40 to 60° C Storage: -40 to 80° C
Humidity	5 to 95% (non-condensing)
Altitude	-100m to 4000m
MTBF (hrs)	830,000

Warning

The operating description in this Instruction Manual is for use by qualified personnel only. To avoid electrical shock, do not perform any servicing of this unit other than that contained in the operating instructions, unless you are qualified and certified to do so by Omnitron Systems Technology, Inc.

Warranty

This product is warranted to the original purchaser against defects in material and workmanship for a period of TWO YEARS from the date of shipment. A LIFETIME warranty may be obtained by the original purchaser by REGISTERING this product with Omnitron within 90 days from the date of shipment. TO REGISTER, COMPLETE AND MAIL OR FAX THE ENCLOSED REGISTRATION FORM. Or you may register your product on the Internet at www.omnitron-systems.com. During the warranty period, Omnitron will, at its option, repair or replace a product which is proven to be defective.

For warranty service, the product must be sent to an Omnitron designated facility, at Buyer's expense. Omnitron will pay the shipping charge to return the product to Buyer's designated US address using Omnitron's standard shipping method.

Limitation of Warranty

The foregoing warranty shall not apply to defects resulting from improper or inadequate use and/or maintenance of the equipment by Buyer, Buyer-supplied equipment, Buyer-supplied interfacing, unauthorized modifications or tampering with equipment (including removal of equipment cover by personnel not specifically authorized and certified by Omnitron), or misuse, or operating outside the environmental specification of the product (including but not limited to voltage, ambient temperature, radiation, unusual dust, etc.), or improper site preparation or maintenance.

No other warranty is expressed or implied. Omnitron specifically disclaims the implied warranties of merchantability and fitness for any particular purpose.

Page 15

Exclusive Remedies

The remedies provided herein are the Buyer's sole and exclusive remedies. Omnitron shall not be liable for any direct, indirect, special, incidental, or consequential damages, whether based on contract, tort, or any legal theory.

TECHNICAL SUPPORT:

For help with this product, contact our Technical Support:

Phone: (949) 250-6510
 Fax: (949) 250-6514
 Address: Omnitron Systems Technology, Inc.
 38 Tesla
 Irvine, CA 92618 USA
 E-mail: support@omnitron-systems.com
 URL: www.omnitron-systems.com

Form: 040-08520-001F 10/13

Page 16