



**DESCRIPTION**

The iConverter GM4 is an intelligent Network Interface Device (NID), that delivers advanced Carrier Ethernet services and provides demarcation at the edges of a network.

The GM4 supports carrier-class Ethernet Service OAM standards. IEEE 802.1ag Connectivity Fault Management (CFM) proactively monitors service availability and provides tools for rapid fault isolation. ITU-T Y.1731 adds Performance Monitoring to monitor key SLA parameters including frame delay, frame delay variation, and frame loss.

For Ethernet Service Activation Testing, the GM4 supports ITU-T Y.1564 and IETF RFC 2544. The GM4 can also be configured to respond to 3rd party test equipment (JDSU and VeEX) and initiate or respond to RFC 5357 Two-Way Active Measurement Protocol (TWAMP) protocol.

The GM4 supports IPv4 and IPv6 addressing, IP-Less protocol using the 802.3ah OAM channel, SNMPv1/v2c/v3, Telnet and serial console port.

[See data sheet for available models.](#)

For complete user manuals, register for access to the [Menu Driven Interface \(89xxUM-02x\)](#) and [Command Line Interface \(89xxUM-01x\)](#) GM4 User Manuals.

**RECOVERING ACCESS TO THE GM4**

In the event the username and/or password is unknown, the GM4 will revert to its factory default username and password for 60 seconds after a power cycle. Using the factory default IP address, username and password, access the GM4. A recovery prompt will be displayed, allowing the username and/or password to be modified.

**FRONT PANEL**

The front of the GM4 provides access to the serial console (management), RJ-45, SFP and Fixed-Fiber ports. The SFP ports support 100/1000BASE-X SFP fiber and 10/100/1000BASE-T copper transceivers.

**Serial Console Port**

The module can be configured by attaching the serial port to a DB-9 serial (RS-232) equipped computer with terminal emulation software such as ProComm or Putty. The Serial Console Port (DCE) is a mini DIN-6 female connector which can be changed to a DB-9 connector with the included adapter. Attach the ends of a serial cable to the serial port of the PC and the Serial Console Port of the module. The port is a standard RS-232 asynchronous serial interface. The pin-outs are illustrated below.

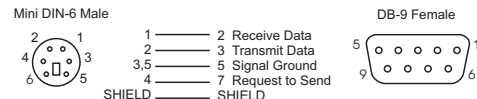

Some computers do not come with DB-9 serial port connectors and may require a USB-to-serial port adapter.

The port is a standard RS-232 asynchronous serial interface. The serial ports is configured for 57,600bps, 1 stop, 8 data, parity none.

**RJ-45, SFP and Fixed-Fiber Ports**

The RJ-45 Ethernet port supports 10BASE-T, 100BASE-TX and 1000BASE-T protocols, auto-negotiation, auto MDI/MDI-X crossover and can be manually forced to a specific speed and duplex mode.

The SFP interfaces support SERDES 100BASE-FX or 1000BASE-X fiber transceivers and SGMII 10/100/1000BASE-T copper transceivers. The SFP interfaces operate in manual mode or auto-negotiation and support full duplex operation.

**NOTE: When using 100BASE-FX SGMII SFPs, the port must be manually configured using the Command Line Interface (CLI). Interface settings can be changed using the port command.**

Fixed-fiber connectors are available with multimode (MM) dual fiber, single-mode (SM) dual fiber and single-mode single-fiber (SF) options. They support ST and SC connectors.

All ports can be enabled or disabled via network management. A port disabled with Port Access Control Setup will still connect and allow 802.3ah Link OAM monitoring, but blocks normal data traffic.

**DIP-SWITCH SETTINGS**

The GM4 has two banks of DIP-switches. The location of the DIP-switches is shown in below.

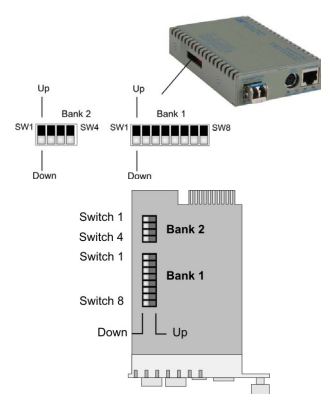

**DIP-SWITCH BANK 1**

**DIP-switch Bank 1 Settings: 2-Port Models**

The function of DIP-switch Bank 1 is outlined below.

Switch Position	Description	DOWN (Off)	UP (On)
1	P1 AN/MAN	AN	MAN
2	P2 AN/MAN	AN	MAN
3	P2 1000/10-100	1000Mbps	10 or 100Mbps
4	P2 100/10	100Mbps	10Mbps
5	P2 FDX/HDX	FDX	HDX
6 - 8	See Link Mode descriptions		

**SW3 - SW5 are reserved for SFP/SFP models**

**SW1: P1 Negotiation "AN/MAN" - All Models**

When this DIP-switch is in the "AN" position (factory default), the port automatically determines the duplex and pause modes of the connected remote device. When this DIP-switch is in the "MAN" position, no capabilities are advertised and the fiber port will operate in full-duplex mode.

**NOTE:** When Port 1 is a copper port, the port will operate at 100Mbps full-duplex when configured for Manual operation.

**SW2: P2 Negotiation "AN/MAN" - SFP/SFP Model**

When this DIP-switch is in the "AN" position (factory default), the port automatically determines the duplex and pause modes of the connected remote device. When this DIP-switch is in the "MAN" position, no capabilities are advertised and the fiber port will operate in full-duplex mode.

**SW2 - SW5: Port 2 Speed/Duplex - All Copper Models**

When port speed is set to 1000, the port always operates in auto-negotiation.

SW2	SW3	SW4	SW5	RJ-45 Mode of Operation
AN	1000	100 or 10	FDX	Port is set to AN with the following modes advertised: 1000F, 1000H, 100F, 100H, 10F, 10H
AN	1000	100 or 10	HDX	Port is set to AN with the following modes advertised: 1000H, 100F, 100H, 10F, 10H
AN	100-10	100	FDX	Port is set to AN with the following modes advertised: 100F, 100H, 10F, 10H
AN	100-10	100	HDX	Port is set to AN with the following modes advertised: 100H, 10F, 10H
AN	100-10	10	FDX	Port is set to AN with the following modes advertised: 10F, 10H
AN	100-10	10	HDX	Port is set to AN with the following modes advertised: 10H
Man	1000	N/A	FDx	Port is set to AN with the following modes advertised: 1000F
Man	1000	N/A	HDx	Port is set to AN with the following modes advertised: 1000H
Man	100-10	100	FDX	Port is set to: 100F
Man	100-10	100	HDX	Port is set to: 100H
Man	100-10	10	FDX	Port is set to: 10F
Man	100-10	10	HDX	Port is set to: 10H

**SW3, SW4 and SW5: Reserved - SFP/SFP Model**

These DIP-switches are reserved and must be in the DOWN (default) position.

**SW6, SW7, SW8: Link Modes**

These three DIP-switches configure the link mode settings. It is recommended to have link modes DOWN "Off" position (default) during the initial installation. After the circuit has been tested and operational, configure the module for the desired mode.

SW6	SW7	SW8	Function
Down	Down	Down	Link Segment (LS)
Up	Down	Down	Link Propagate (LP)
Down	Up	Down	Remote Fault Detect + Link Segment (RFD+LS)
Up	Up	Down	Remote Fault Detect + Link Propagate (RFD+LP)
Down	Down	Up	Symmetrical Fault Detect (SFD)
Up	Down	Up	Asymmetrical Link Propagate Port 1 to Port 2 (ALP P1 P2)
Down	Up	Up	Asymmetrical Link Propagate Port 2 to Port 1 (ALP P2 P1)
Up	Up	Up	Asymmetrical Link Propagate Port 1 to Port 2 + Port 1 RFD (ALP P1 P2 + P1 RFD)

**NOTE:** Configuring both link partners for RFD will cause a "deadly embrace" lockup condition during a link failure. This is an illegal setting.

**NOTE:** The RFD link mode will only operate when the interface is configured for Manual "MAN" operation.

For detailed information on the operation of the different Link Modes, download the [iConverter Link Mode Application Note](#).

**DIP-switch Bank 1 Settings: 3-Port Models**

The function of DIP-switch Bank 1 is outlined below.

Switch Position	Description	DOWN (Off)	UP (On)
1	P1 AN/MAN	AN	MAN
2	P2 AN/MAN	AN	MAN
3	P3 AN/MAN	AN	MAN
4	Return to Primary	RTP	OFF
5	Redundancy	NORM	1:1
6 - 8	See Link Mode descriptions		

**DIP-switch Bank 1 for 3-Port Models**

**SW1, SW2 - P1, P2 Negotiation "AN/MAN"**

When these DIP-switches are in the "AN" position (factory default), the port automatically determines the duplex and pause modes of the connected remote device. If the connected remote device cannot provide the proper signal to indicate its own mode of operation, the DIP-switch should be set to the "MAN" position. When in manual mode, no capabilities are advertised and the fiber port will operate in full-duplex mode.

**NOTE: When Port 1 and/or Port 2 is copper, the port will operate at 100Mbps full-duplex when configured for Manual operation.**

**SW3 - P3 Auto/Manual Negotiation "AN/MAN"**

When this DIP-switch is in the "AN" position (factory default), the port automatically determines the duplex and pause modes of the connected remote device. When the DIP-switch is in the "MAN" position, the port is forced to 100M FDX.

**SW4 and SW5 - Port Redundancy**

The module can be configured for port redundancy. When configured for port redundancy, the module will transmit and receive traffic on the primary port (Port 1) and no traffic on the backup port (Port 2). When a fiber failure occurs on the primary port, the module will switch over to the backup port within 50msec.

**NOTE: 50msec failover is only supported on the fiber ports.**

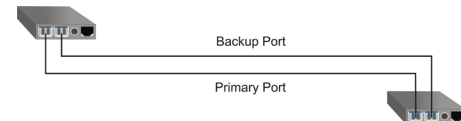

DIP-switches SW4 and SW5 control the port redundancy mode of the module. When SW5 is in the "NORM" (factory default) position, the ports operate in a non-redundant (independent) mode. When SW5 is in the "1:1" position, the module is configured for port redundancy and operates

based on the position of SW4. When SW4 is in the "RTP" (factory default) position, the module will switch back to the primary port (Port 1) once a stable connection has been established. When SW4 is in the "OFF" position, the module will remain on the backup port (Port 2) even when a stable connection has been established on Port 1. See Port Redundancy Modes table for more information.

**NOTE:** The ports must have MAC learning disabled to perform a 50msec switch over.

SW4	SW5	Function
Down	Down	Non-redundant mode - independent mode
Up	Down	Non-redundant mode - independent mode
Down	Up	Redundant mode - return to primary (RTP)
Up	Up	Redundant mode - no return to primary

**SW6, SW7 and SW8 - Link Modes**

These DIP-switches control the link failure behavior. The module supports eight different link modes. It is recommended to have the DIP-switches in the DOWN (factory default) position during the initial installation. After the circuit has been tested and operational, configure the module for the desired mode.

SW6	SW7	SW8	Function Link Mode Association	Port
Down	Down	Down	Link Segment (LS) Independent	AN or MAN
Up	Down	Down	Asymmetrical Link Propagate Redundant Uplink (ALP RU) P1 + P2 → P3	AN
Down	Up	Down	Asymmetrical Link Propagate Multi-Tenant 1 (ALP MT1) P3 → P1 & P2	AN
Up	Up	Down	Asymmetrical Link Propagate Multi-Tenant 2 (ALP MT2) P1 → P2 & P3	AN

SW6	SW7	SW8	Function Link Mode Association	Port
Down	Down	Up	Remote Fault Detect (RFD 3P) Independent	MAN
Up	Down	Up	Asymmetrical Link Propagate + Remote Fault Detect Redundant Uplink (ALP+RFD RU) P1 + P2 → P3	MAN
Down	Up	Up	Asymmetrical Link Propagate + Remote Fault Detect Multi-Tenant 1 (ALP+RFD MT1) P3 → P1 & P2	MAN
Up	Up	Up	Asymmetrical Link Propagate + Remote Fault Detect Multi-Tenant 2 (ALP+RFD MT2) P1 → P2 & P3	MAN

Link mode association describes the relationship between the port(s) experiencing a fault condition and what port(s) the fault will propagate. P1+P2 → P3 indicates faults on both Port 1 and Port 2 will propagate to Port 3. If only Port 1 or Port 2 has a fault, the fault will not be propagated to Port 3. It requires faults on both ports to propagate a fault condition.

**NOTE:** Configuring both link partners for RFD will cause a "deadly embrace" lockup condition during a link failure. This is an illegal setting.

**NOTE:** The RFD link mode will only operate when the interface is configured for Manual "MAN" operation.

For detailed information on the operation of the different Link Modes, download the [iConverter Link Mode Application Note](#).

**DIP-SWITCH BANK 2**

**DIP-switch Bank 2 Settings: All Models**

The function of DIP-switch Bank 2 is outlined below.

Switch Position	Description	DOWN (Default)	UP
1	Backplane A	Disable	Enable
2	Backplane B	Disable	Enable
3	Master/Slave	M/SL	SL
4	Zero Touch	Disable	Enable

**SW1 - SW3 are reserved for all standalone models and must be left in the default DOWN position.**

**SW1 and SW2: Backplane Enable**

This feature is only supported on chassis plug-in modules.

When these DIP-switches are in the "DISABLE" position, the Backplane Port of the plug-in module is isolated from the Ethernet Backplane on the chassis. When these DIP-switches are in the "ENABLE" position, the Backplane Port is enabled. This allows Ethernet Backplane connectivity to an adjacent module via the chassis A/B Backplane Link depending on the switch setting.

**SW3: Master/Slave**

This feature is only supported on chassis plug-in modules.

Setting this DIP-switch to the "M/SL" position (factory default), allows chassis mastership to be automatically negotiated by the installed management modules.

When an Network Management Module (NMM2) is installed in the chassis, the NMM2 will always be the master, otherwise the lowest slot number with a management module installed will become the chassis master.

To designate the GM4 module as the master of the chassis when a Network Management Module (NMM2) is not installed, set the DIP-switch on the module to the Down "M/SL" position, and set the DIP-switch on the other

installed management modules to the Up "SL" position to enable Slave-Only mode.

Only the chassis master can change the configuration settings of other modules. When Slave Write is enabled on a slave management module, the management module can be modified by directly connecting to the serial console port.

**SW4: Zero Touch**

Zero Touch Provisioning (ZTP) utilizes DHCP and TFTP to automatically configure the module during the initial setup. ZTP can be enabled/disabled using this hardware DIP-switch or the CLI *autoconfig* command.

Zero Touch is disabled by default. The ZTP process is configured by setting this DIP-switch to the UP position (enabled). When ZTP is enabled, the module will start the DHCP process on power up or module reboot.

**APPLY POWER**

**AC Power - Standalone Modules**

Secure the ground wire to the ground screw located on the back of the module.

Route the power cord through the provided strain relief for additional support and connect the barrel connector at the end of the wire on the AC/DC adapter to the barrel connector on the module. Connect the AC/DC adapter to the AC outlet. Confirm that the module has powered up properly by checking the Power LED located on the front of the module.

**WARNING!!!**  
NEVER ATTEMPT TO OPEN THE CHASSIS OR SERVICE THE POWER SUPPLY. OPENING THE CHASSIS MAY CAUSE SERIOUS INJURY OR DEATH. THERE ARE NO USER REPLACEABLE OR SERVICEABLE PARTS IN THIS UNIT.

**DC Power - Standalone Modules**

This module is intended for installation in restricted access areas. ("Les matériels sont destinés à être installés dans des EMBLEMES À ACCÈS RESTREINT"). A restricted access area can be accessed only through the use of a special key, or other means of security.

The over current protection for connection with centralized DC shall be provided in the building installation, and shall be a UL listed circuit breaker rated 20 Amps, and installed per the National Electrical Code, ANSI/NFPA-70.

Appropriate overloading protection should be provided on the DC power source outlets utilized.

The standalone module requires +8 to +60VDC inclusive of tolerances (1.2A @ 9VDC max rated power). See specification table for specific model requirements.

Appropriate overloading protection should be provided on the DC power source outlets utilized.

**WARNING:** Only a DC power source that complies with safety extra low voltage (SELV) requirements can be connected to the DC-input power supply.

**WARNING REGARDING EARTHING GROUND:**

- This equipment shall be connected to the DC supply system earthing electrode conductor or to a bonding jumper from an earthing terminal bar or bus to which the DC supply system earthing electrode is connected.
- This equipment shall be located in the same immediate area (such as adjacent cabinets) as any other equipment that has a connection between the earthed conductor of the same DC supply circuit and the earthing conductor, and also the point of earthing of the DC system. The DC system shall not be earthed elsewhere.
- The DC supply source is to be located within the same premises as this equipment.
- There shall be no switching or disconnecting devices in the earthed circuit conductor between the DC source and the earthing electrode conductor.

Locate the DC circuit breaker of the external power source, and switch the circuit breaker to the OFF position.

Prepare a power cable using a three conductor insulated wire (not supplied) with 12AWG to 14AWG thickness. Cut the power cable to the length required.

Strip approximately 3/8 of an inch of insulation from the power cable wires.

Connect the ground wire to the grounding screws on the back of the module.

Connect the power cables to the module by fastening the stripped ends to the DC power connector.

**WARNING:** The positive lead of the power source must be connected to the "+" terminal on the module and the negative lead of the power source to the "-" terminal on the module as shown above.

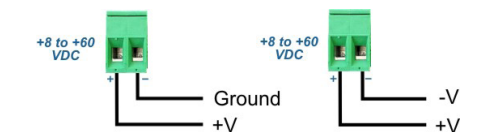

**WARNING:** Note the wire colors used in making the positive, negative and ground connections. Use the same color assignment for the connection at the circuit breaker.

Connect the power wires to the circuit breaker and switch the circuit breaker ON. If any module are installed, the Power LED will indicate the presence of power.

During the installation, ensure that the ground potentials are maintained throughout the system connections. This includes but not limited to the power source ground and any shielded cabling grounds.

**WARNING!!!**  
NEVER ATTEMPT TO OPEN THE CHASSIS OR SERVICE THE POWER SUPPLY. OPENING THE CHASSIS MAY CAUSE SERIOUS INJURY OR DEATH. THERE ARE NO USER REPLACEABLE OR SERVICEABLE PARTS IN THIS UNIT.

Make sure to disconnect the power and ground cables before removing the equipment.

## MOUNTING AND CABLE ATTACHMENT

### Wall Mounting - Standalone Module

The wall mounting height of the module should be less than or equal to 2 meters (6.6 feet) from the floor.

The standalone module is available with or without integrated mounting brackets. When using the standalone module with integrated mounting brackets, use the four mounting holes on the module to secure the module to the wall. The module can accommodate #6 screws (not included).

Standalone modules without mounting brackets can use the optional mounting bracket kit (2x 4381). Use the four mounting holes on the module to secure the module to the wall. The module can accommodate #6 screws (not included).

Installation of the module should be such that the air flow in the front, back, side and top vents of the switch are not compromised or restricted.

The accessory cables should have their own strain relief and do not pull down on the module.

### Rack Mounting - Standalone Module

The standalone modules with integrated mounting brackets or using the optional mounting bracket kit can be rack mounted using the optional Rack Mount Shelf (8260-0). Refer to the Rack Mount Shelf user manual (040-08260-001x) for the proper installation guidelines. The user manual is available on the iConverter Rack Mount Shelf product page at: [www.omnitrion-systems.com](http://www.omnitrion-systems.com)

Follow the same guidelines above when rack mounting the module.

## Chassis Mounting - Plug-in Modules

**Caution:** Use proper ESD protection to reduce the risk of damage to your equipment.

Carefully slide the module into an open slot in the chassis. Align the module with the installation guides and ensure that the module is firmly seated against the backplane. Secure the module by fastening the front panel thumbscrew (push in and turn clockwise to tighten) to the chassis front.

### Plug-In and Standalone Modules

1. Insert the SFP fiber transceiver into the SFP receptacle on the front of the module (see the SFP Data Sheet 091-17000-001 for supported Fast/Gigabit transceivers).

**NOTE:** The release latch of the SFP fiber transceiver must be in the closed (up) position before insertion.

The module has the ability to detect the speed and automatically configure the port to match the speed of approved SFP transceivers. Some SFP fiber transceivers will need to be configured using the CLI *portattribute* commands to configure the speed of the port to match the speed of the installed SFP transceiver.

2. Connect an appropriate multimode or single-mode fiber cable to the fiber port on the front of the module. It is important to ensure that the transmit (TX) is attached to the receive side of the transceiver at the other end and the receive (RX) is attached to the transmit side. When using single-fiber (SF) models, the TX wavelength must match the RX wavelength at the other end and the RX wavelength must match the TX wavelength at the other end.

3. Connect the Ethernet 10/100/1000 RJ-45 port using a Category 5 or better Ethernet cable to an external 10BASE-T, 100BASE-TX or 1000BASE-T Ethernet device.

## LED INDICATORS

### 2 Port Models

LED	Color	Description
Power "PWR"	Green	OFF: No power ON: Module has power
P1 Link Activity "100" Not available on FF models	Green	OFF: Port not linked at 100M ON: Port linked at 100M Blinking: Data activity
P1 Link Activity "1000"	Green	OFF: Port not linked at 1000M ON: Port linked at 1000M Blinking: Data activity
P1 Link Activity "100" and "1000" Not available on FF models	Green	OFF: Port not linked at 10M ON: Port linked at 10M Blinking: Data activity
Test/Alarm "Tst/Alm"	Green	Reserved
Management Mode "Msr/Slv"	Green	OFF: N/A ON: Master (normal) 5 Hz Blinking: Remote Slave
P2 Link Activity "100"	Green	OFF: Port not linked at 100M ON: Port linked at 100M Blinking: Data activity
P2 Link Activity "1000"	Green	OFF: Port not linked at 1000M ON: Port linked at 1000M Blinking: Data activity
P2 Link Activity "100" and "1000"	Green	OFF: Port not linked at 10M ON: Port linked at 10M Blinking: Data activity

### 3 Port Models

LED	Color	ON/Blinking State
Power "PWR"	Green	OFF: No power ON: Module has power
P1 Link Activity "100"	Green	OFF: Port not linked at 100M ON: Port linked at 100M Blinking: Data activity
P1 Link Activity "1000"	Green	OFF: Port not linked at 1000M ON: Port linked at 1000M Blinking: Data activity
P1 Link Activity "100" and "1000"	Green	OFF: Port not linked at 10M ON: Port linked at 10M Blinking: Data activity
P2 Link Activity "100"	Green	OFF: Port not linked at 100M ON: Port linked at 100M Blinking: Data activity
P2 Link Activity "1000"	Green	OFF: Port not linked at 1000M ON: Port linked at 1000M Blinking: Data activity
P2 Link Activity "100" and "1000"	Green	OFF: Port not linked at 10M ON: Port linked at 10M Blinking: Data activity
Test/Alarm "Tst/Alm"	Green	Reserved
Management Mode "Msr/Slv"	Green	OFF: N/A ON: Master (normal) 5 Hz Blinking: Remote Slave
P3 Link Activity "100"	Green	OFF: Port not linked at 100M ON: Port linked at 100M Blinking: Data activity
P3 Link Activity "1000"	Green	OFF: Port not linked at 1000M ON: Port linked at 1000M Blinking: Data activity
P3 Link Activity "100" and "1000"	Green	OFF: Port not linked at 10M ON: Port linked at 10M Blinking: Data activity

## All Models

LED		Link Speed
"1000"	"100"	
OFF	OFF	Port not linked
OFF	ON	Port linked at 100Mbps
ON	OFF	Port linked at 1000Mbps
ON	ON	Port linked at 10Mbps

## MECHANICAL

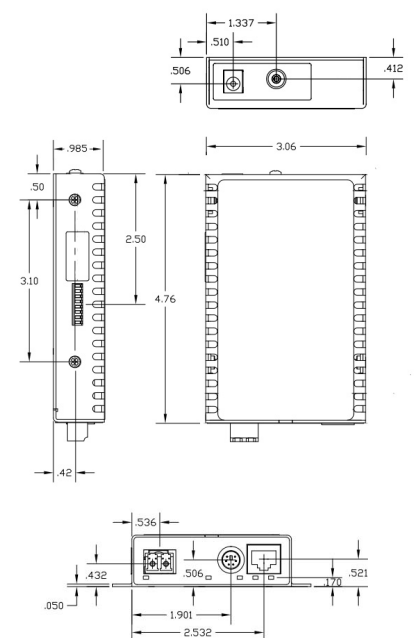
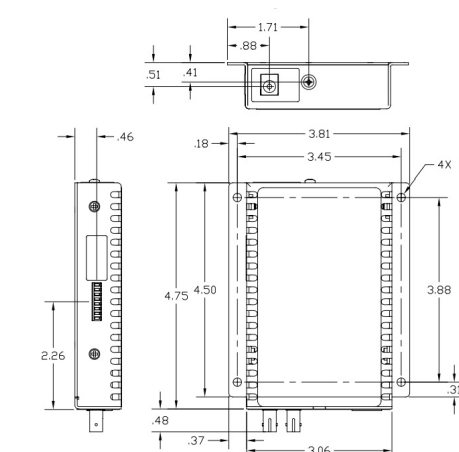

## SPECIFICATIONS

<b>Standard Compliances</b>	IEEE 802.1Q, 802.1ad, 802.1ax, 802.1p, 802.3, 802.3ad, 802.3ah*, 802.1ag, 1588v2 RFC 2819 (RMON), 2863 (IF-MIB), 2131 (DHCP), 2544, 5357 ITU-T G.8031, G.8032, G.8262, Y.1731, Y.1564, MEF 9, 14, 21, 30, 31, Carrier Ethernet 2.0
<b>Regulatory Compliances</b>	Safety: UL, CE, NEBS Level 3, UKCA EMI: FCC Class A ACT: TAA, BAA, NDAA
<b>Environmental</b>	RoHS, WEEE, REACH
<b>Management</b>	IPv4, IPv6, Telnet, SNMPv1, SNMPv2c, SNMPv3, Serial Console
<b>Frame Size</b>	Up to 10,240 bytes
<b>Port Types</b>	Copper: 10/100/1000BASE-T (RJ-45) 10/100/1000BASE-T SGMII Transceiver Fiber: 1000BASE-X (SFP, ST, SC, LC) 100BASE-X (SFP) Serial: RS-232 (Mini DIN-6 female) Mini DIN-6 to DB-9 adapter included
<b>Cable Types</b>	Copper: EIA/TIA 568A/B, Cat 5 and higher Fiber: Multimode: 50/125µm, 62.5/125µm Single-mode: 9/125µm Serial: RS-232, 22 to 24 AWG, 12 to 50 pF/ft
<b>AC Power Requirements</b>	AC Adapter: 100 - 240VAC/50 - 60Hz, 0.1A @ 120VAC
<b>DC Power Requirements</b>	DC Input: (Backplane) 2-Port: 2.56A @ 3.3VDC 3-Port: 2.85A @ 3.3VDC Terminal: 2-Pin Terminal (non-isolated) 8 - 60VDC inclusive of tolerance 1.2A @ 9VDC (typical), 1.0A @ 12VDC (typical) AC Adapter: 2.5mm Barrel Connector 8 - 60VDC inclusive of tolerance 1.2A @ 9VDC (typical), 1.0A @ 12VDC (typical)

\*IEEE 802.3ah Link OAM with Dying Gasp

Supported on all standalone models. Supported on plug-in models when installed in a 1-Module or 2-Module chassis with dying gasp support.

## SPECIFICATIONS

<b>Dimensions W x D x H</b>	Plug-in: 0.85" x 4.5" x 2.8" (21.59 mm x 114.3 mm x 71.12 mm) Standalone: 3.1" x 4.8" x 1.0" (78.74 mm x 121.92 mm x 25.4 mm) Standalone w/ integrated mounting brackets: 3.8" x 4.8" x 1.0" (96.52 mm x 121.92 mm x 25.4 mm)
<b>Weight</b>	Plug-in: 8 oz. (226.79 grams) Standalone w/o AC adapter: 1.0 lbs. (0.454 kg) Standalone w/ AC adapter: 1.5 lbs. (0.680 kg)
<b>Temperature</b>	Commercial: 0 to 50°C Wide: -40 to 60°C (-20°C AC cold start) Extended: -40 to 75°C (-20°C AC cold start) Storage: -40 to 80°C
<b>Humidity</b>	5 to 95% (non-condensing)
<b>Altitude</b>	-100m to 4,000m
<b>MTBF (hrs)</b>	Plug-in: 340,000 Standalone Module with or without AC Adapter: 100,000
<b>Warranty</b>	3 year warranty and 24/7/365 free Technical Support

## General and Copyright Notice

This publication is protected by U.S. and international copyright laws. All rights reserved. The whole or any part of this publication may not be reproduced, stored in a retrieval system, translated, transcribed, or transmitted, in any form, or by any means, manual, electric, electronic, electromagnetic, mechanical, chemical, optical or otherwise, without prior explicit written permission of Omnitrion Systems Technology, Inc.

The following trademarks are owned by Omnitrion Systems Technology, Inc.: FlexPoint™, FlexSwitch™, iConverter®, miConverter™, NetOutlook®, OmniLight®, OmniConverter®, RuggedNet®, Omnitrion Systems Technology, Inc.™, OST™ and the Omnitrion logo.

All other company or product names may be trademarks of their respective owners.

The information contained in this publication is subject to change without notice. Omnitrion Systems Technology, Inc. is not responsible for any inadvertent errors.

### Warranty

This product is warranted to the original purchaser (Buyer) against defects in material and workmanship for a period of two (2) years from the date of shipment. The warranty for the network product can be extended to three (3) years by registering this product at [www.omnitrion-systems.com/support](http://www.omnitrion-systems.com/support) within ninety (90) days from the date of shipment. During the warranty period, Omnitrion will, at its option, repair or replace a product which is proven to be defective with the same product or with a product with at least the same functionality.

For warranty service, the product must be sent to an Omnitrion designated facility, at Buyer's expense. Omnitrion will pay the shipping charge to return the product to Buyer's designated US address using Omnitrion's standard shipping method.

### Limitation of Warranty

The foregoing warranty shall not apply to product malfunctions resulting from improper or inadequate use and/or maintenance of the equipment by Buyer,

Buyer-supplied equipment, Buyer-supplied interfacing, unauthorized modifications or tampering with equipment (including removal of equipment cover by personnel not specifically authorized and certified by Omnitrion), or misuse, or operating outside the environmental specification of the product (including but not limited to voltage, ambient temperature, radiation, unusual dust, etc.), or improper site preparation or maintenance.

No other warranty is expressed or implied. Omnitrion specifically disclaims the implied warranties of merchantability and fitness for any particular purpose.

The remedies provided herein are the Buyer's sole and exclusive remedies. Omnitrion shall not be liable for any direct, indirect, special, incidental, or consequential damages, whether based on contract, tort, or any legal theory.

### Environmental Notices

The equipment covered by this manual must be disposed of or recycled in accordance with the Waste Electrical and Electronic Equipment Directive (WEEE Directive) of the European Community directive 2012/19/EU on waste electrical and electronic equipment (WEEE) which, together with the RoHS Directive 2015/863/EU, for electrical and electronic equipment sold in the EU after July 2019. Such disposal must follow national legislation for IT and Telecommunication equipment in accordance with the WEEE directive: (a) Do not dispose waste equipment with unsorted municipal and household waste. (b) Collect equipment waste separately. (c) Return equipment using collection method agreed with Omnitrion.



## Safety Warnings and Cautions



ATTENTION: Observe precautions for handling electrostatic discharge sensitive devices.



WARNING: Potential damage to equipment and personal injury.



WARNING: Risk of electrical shock.

## Customer Support Information

Phone: (949) 250-6510  
Fax: (949) 250-6514  
Address: Omnitrion Systems Technology, Inc.  
38 Tesla  
Irvine, CA 92618, USA  
Email: [support@omnitrion-systems.com](mailto:support@omnitrion-systems.com)  
URL: [www.omnitrion-systems.com](http://www.omnitrion-systems.com)