

# iConverter® 4xT1/E1 MUX Multiplexer

## User Manual

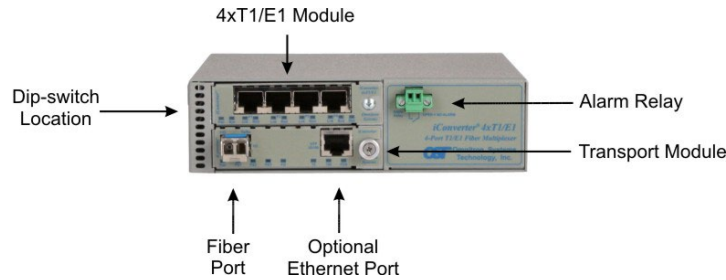

### Description

The iConverter 4xT1/E1 MU multiplexes four T1/E1s and an optional Ethernet onto a fiber optic transport link, and features testing and configuration capabilities. The iConverter 4xT1/E1 MUX operates in a back-to-back configuration, with one multiplexer at each end of the fiber transport link.

The 4xT1/E1 MUX/M consists of a 4xT1/E1 MUX module and a Fast Ethernet fiber transport module installed in a 2-Module chassis.

Fiber transport module is configured for auto-negotiation and a 100Mbps data rate.

### Configure DIP-Switches

DIP-switches are located on the side of the chassis

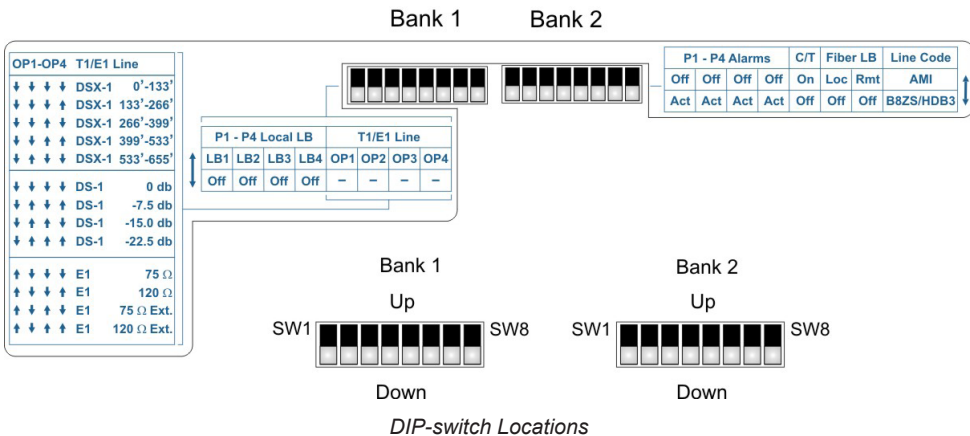

### DIP-switch Bank 1

#### SW1 - SW4: Local Loopback Port 1 - Port 4 "Off / LBx"

These DIP-switches control the local loopback function for each T1/E1 port. When these DIP-switches are in the "LBx" position, the corresponding port initiates a local copper loopback. An AIS (all 1s signal) from the local port is transmitted across the fiber and out the corresponding T1/E1 port on the remote unit. When these DIP-switches are in the "Off" (default) position, the port functions normally.

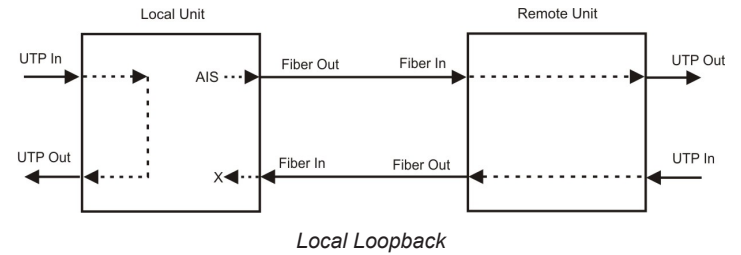

### SW5 - SW8: T1/E1 Line Configuration Settings

These DIP-switches configure the 4xT1/E1 MUX modules for T1/E1 operation and the copper line build-out. This is a global configuration for all ports on the module.

SW5	SW6	SW7	SW8	Description
Down	Down	Down	Down	T1 DSX-1: 0' to 133' (default)
Down	Down	Down	Up	T1 DSX-1: 133' to 266'
Down	Down	Up	Down	T1 DSX-1: 266' to 399'
Down	Down	Up	Up	T1 DSX-1: 399' to 533'
Down	Up	Down	Down	T1 DSX-1: 533' to 655'
Down	Down	Down	Down	T1 DS1: 0dB
Down	Up	Down	Up	T1 DS1: -7.5dB
Down	Up	Up	Down	T1 DS1: -15dB
Down	Up	Up	Up	T1 DS1: -22.5dB
Up	Down	Down	Down	E1 75 Ω Coax/BNC Standard
Up	Down	Down	Up	E1 120 Ω RJ-45/48 Standard
Up	Down	Up	Down	E1 75 Ω Coax/BNC Extended/LH
Up	Down	Up	Up	E1 120 Ω RJ-45/48 Extended/LH

### T1/E1 Line Build-Out

### DIP-switch Bank 2

Switch	Function	Down (default)	Up
SW1	Port 1 Alarm/LEDs Disable	Act (Normal)	Off
SW2	Port 2 Alarm/LEDs Disable	Act (Normal)	Off
SW3	Port 3 Alarm/LEDs Disable	Act (Normal)	Off
SW4	Port 4 Alarm/LEDs Disable	Act (Normal)	Off
SW5	Circuit Test	Off (Normal)	On
SW6	Local Fiber Loopback	Off (Normal)	Loc
SW7	Remote Fiber Loopback	Off (Normal)	Rmt
SW8	Line Code	B8ZS Line Code	AMI line Code

### Bank 2 DIP-switches

#### SW1 - SW4: Port Alarm Relay/LED "Act / Off"

These DIP-switches enable/disable the port alarm relay and LED functions for the corresponding port on the 4xT1/E1 MUX module. When these DIP-switches are in the "Act" position (default), the alarm relay and Link "Lnk" and Remote "Rmt" LEDs are enabled. When these DIP-switches are in the "Off" position, the alarm relay, "Lnk" and "Rmt" LEDs are disabled.

## Port Alarm Relay

The port alarm relay will close when any of the following port alarm conditions are detected (i.e. alarm relay port 1 will activate when an alarm condition is detected on port 1).

- Power loss
- The detection of AIS or Loss of Signal (LoS) on any of the four local T1/E1 copper ports
- The detection of AIS or LoS on any of the four remote T1/E1 copper ports
- When the T1/E1 MUX is not peered with its remote partner

NOTE: The alarm relay uses pins 7 & 8 of port 1 on each 4xT1/E1 MUX module. If more than one 4xT1/E1 MUX module is installed, each alarm relay operates independently from the other modules. The optional breakout cable provides access to the T1/E1 and alarm relay pins: part number 9142-1.

### SW5: Circuit Test (C/T) Mode “Off / On”

When this DIP-switch is in the “Off” position (default), the Circuit Test Mode is disabled. When this DIP-switch is in the “On” position, the Circuit Test Mode is enabled. Circuit Test Mode only needs to be enabled on one end for the test to initiate.

When Circuit Test mode is enabled, both 4xT1/E1 MUX modules will transmit a known test pattern. The test pattern is received by the far end unit and checked for errors. AIS is transmitted out all T1/E1 ports and incoming T1/E1 traffic is discarded. A slow green/yellow alternating “Sys” LED on the initiating end and a fast green/yellow alternating “Sys” LED on the far end indicates a successful test.

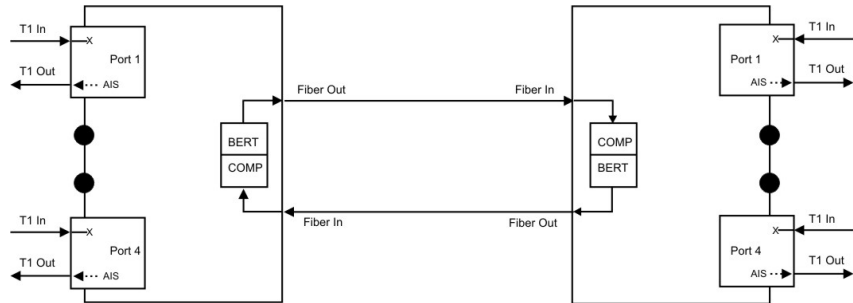

Circuit Test Mode

### SW6: Local Fiber Loopback “Off / Loc”

When this DIP-switch is in the “Off” position (default), local fiber loopback is disabled. When this DIP-switch is in the “Loc” position, local fiber loopback is enabled on the MUX module. AIS is transmitted across the fiber and out all remote T1/E1 ports. Incoming T1/E1 traffic at the remote unit is discarded.

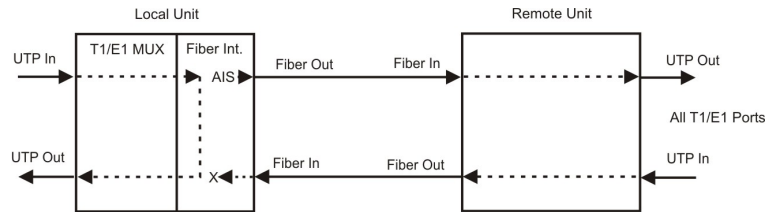

Local Fiber Loopback

NOTE: Only one loopback activation (Local Fiber Loopback or Remote Fiber Loopback) can be configured at the same time.

### SW7: Remote Fiber Loopback “Off / Rmt”

When this DIP-switch is in the “Off” position (default), remote fiber loopback is disabled. When this DIP-switch is in the “Rmt” position, remote fiber loopback is enabled on the 4xT1/E1 MUX module. In this mode, the local unit forces the remote 4xT1/E1 MUX module into loopback. AIS is transmitted out all remote T1/E1 ports. Incoming T1/E1 traffic at the remote unit is discarded.

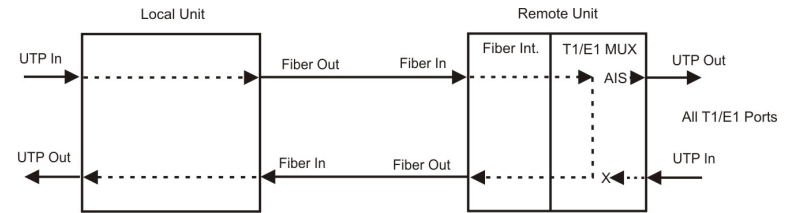

Remote Fiber Loopback

NOTE: Only one loopback activation (Local Fiber Loopback or Remote Fiber Loopback) can be configured at the same time.

### SW8: T1/E1 Line Codes “B8ZS / AMI”

When this DIP-switch is in the “B8ZS” position (default), the 4xT1/E1 MUX module is configured for B8ZS (T1) or HDB3 (E1) line coding. When the DIP-switch is in the “AMI” position, the 4xT1/E1 MUX module is configured for AMI line coding.

## Wall and Rack Mounting

The 2-Module chassis can be wall/rack mounted by attaching the optional wall/rack mount brackets (8249-0). A 19” Rack Mount Shelf (8260-0) is available to install three 2-Module chassis side by side.

The operating temperature of this equipment is 0 to 50 degrees C, -40 to 60 degrees C or -40 to 75 C depending on the model number. If installed in a closed or multi-unit rack assembly, the operating ambient temperature of the rack must not exceed the maximum rated temperature for the chassis used.

Installation of the equipment should be such that the air flow in the front and back of the unit is not compromised or restricted.

Installing this equipment into a rack in such a way as to make it unstable may cause injury or death. Always make sure that the rack you are installing this equipment into is properly secured, stable, balanced and designed to carry the weight and weight distribution of this equipment.

Never use this equipment to carry any weight except its own. Never use it as a shelf to support the weight of other equipment.

## Apply AC Power

Power source should be available within 5 ft. of the chassis and installed per the National Electrical Code, ANSI/NFPA-70.

This equipment requires 100-240VAC, 0.5Amp, 50/60Hz. Appropriate overloading protection should be provided on all AC power source outlets utilized.

The standard operating temperature of this equipment is 0 to 50 degrees C. If installed in a closed or multi-unit rack assembly, the operating ambient temperature of the rack must not exceed the maximum rated 50 degrees C temperature. For wide temperature models, the operating temperature must not exceed 60 degrees C.

Installation of the equipment should be such that the air flow in the front and back of the unit is not compromised or restricted.

Installing this equipment into a rack in such a way as to make it unstable may cause injury or death. Always make sure that the rack you are installing this equipment into is properly secured, stable, balanced and designed to carry the weight and weight distribution of this equipment.

Never use this equipment to carry any weight except its own. Never use it as a shelf to support the weight of other equipment.

Attach the AC power cords (provided for each Power Supply) to the back of each Power Supply and plug into the AC outlets. The fans should immediately begin to run and any installed modules will illuminate the power LEDs.



Rear View with Power Cord

## Apply DC Power

Power source should be available within 5 ft. of the chassis. The over current protection for the connection with centralized DC shall be provided in the building installation and shall be a UL listed breaker rated at 15 Amps, and installed per the National Electrical Code, ANSI/NFPA-70.

This equipment requires 18-60VDC/2.0A rated power. Appropriate overloading protection should be provided on the DC power source outlets utilized.

Appropriate overloading protection should be provided on all DC power source outlets utilized.

**WARNING:** Only a DC power source that complies with safety extra low voltage (SELV) requirements can be connected to the DC-input power supply.

### WARNING REGARDING EARTHING GROUND:

- This equipment shall be connected to the DC supply system earthing electrode conductor or to a bonding jumper from an earthing terminal bar or bus to which the DC supply system earthing electrode is connected.
- This equipment shall be located in the same immediate area (such as adjacent cabinets) as any other equipment that has a connection between the earthed conductor of the same DC supply circuit and the earthing conductor, and also the point of earthing of the DC system. The DC system shall not be earthed elsewhere.
- The DC supply source is to be located within the same premises as this equipment.
- There shall be no switching or disconnecting devices in the earthed circuit conductor between the DC source and the earthing electrode conductor.

The standard operating temperature of this equipment is 0 to 50 degrees C. If installed in a closed or multi-unit rack assembly, the operating ambient temperature of the rack must not exceed the maximum rated 50 degrees C temperature. For wide temperature models, the operating temperature must not exceed 60 degrees C. For extended temperature models, the operating temperature must not exceed 75 degrees C.

Installation of the equipment should be such that the air flow in the front and back of the unit is not compromised or restricted.

Installing this equipment into a rack in such a way as to make it unstable may cause injury or death. Always make sure that the rack you are installing this equipment into is properly secured, stable, balanced and designed to carry the weight and weight distribution of this equipment.

Never use this equipment to carry any weight except its own. Never use it as a shelf to support the weight of other equipment.

Locate the DC circuit breaker and switch the circuit breaker to the OFF position.

Prepare a power cable using a three conductor insulated wire (not supplied) with a 14 AWG gauge. Cut the power cable to the length required.

Strip approximately 3/8 of an inch of insulation from the power cable wires.

Connect the power cables to the Chassis by fastening the stripped ends to the DC power connector.

**WARNING:** Note the wire colors used in making the positive, negative and ground connections. Use the same color assignment for the connection at the circuit breaker.

Connect the power wires to the circuit breaker and switch the circuit breaker ON. The fans should immediately begin to run and any installed modules will illuminate the power LEDs.

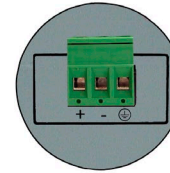

Rear View with DC Power Connector

## Connect the Cables

1. Connect a Category 3 or better cable (Category 5 is recommended) to the RJ-48C connectors on the 4xT1/E1 MUX modules, and attach the other end of the UTP cable to the network equipment. The pinout for the RJ-48C is:

- Pin 1 Customer Interface R1 – receive ring (C R1)
- Pin 2 Customer Interface T1 – receive tip (C T1)
- Pin 4 Customer Interface R – transmit ring (C R)
- Pin 5 Customer Interface T – transmit tip (C T)
- Pin 7 Alarm relay B (port 1 only) (AR B)
- Pin 8 Alarm relay A (port 1 only) (AR A)

**NOTE: Generally, a straight through cable is used at the head-end and a T1 crossover cable (Pin 1 to Pin 4, Pin 2 to Pin 5) is used at the far-end.**

2. The 4xT1/E1 MUX module features dry relay contacts for optionally connecting the it into a separate T1/E1 alarm circuit. The relay closes on:

- Power loss
- The detection of AIS or Loss of Signal (LoS) on any of the four local T1/E1 copper ports
- The detection of AIS or LoS on any of the four remote T1/E1 copper ports
- When the T1/E1 MUX is not peered with its remote partner

To utilize the alarm relay contacts, connect a two conductor insulated wire (not supplied) to pins 7 and 8 on the RJ-48 connector. Connect the other ends of the cable to the alarm detection device. See specification below for the maximum voltage ratings supported by the alarm relay.

Relay Contact Ratings (pins 7 & 8 on RJ-48 port)	
Manufacturer Spec	UL/CSA
220V DC, 30W, 250V AC, 37.5VA, 1A max	30V DC, 1A (resistive) 110V DC, 0.3A (resistive) 125V AC, 0.5A (resistive)

3. When configured for E1 coax operation, use the optional adapter cables to convert the RJ-48C interface ports to dual BNC (part number 9140-3) and set the T1/E1 Line Configuration DIP-switch for E1 75 Ω Coax.

4. Insert the SFP fiber transceivers into the SFP receptacles on the TM3 module.

**NOTE: The release latch of the SFP fiber transceiver must be in the closed (up) position before insertion.**

5. Connect the appropriate multimode or single-mode fiber cable to the fiber port of the installed module. It is important to ensure that the transmit (TX) is attached to the receive side of the device at the other end and the receive (RX) is attached to the transmit side. When using single-fiber (SF) TM3 models, the TX wavelength must match the RX wavelength at the other end and the RX wavelength must match the TX wavelength at the other end.

6. When using a model with the optional Ethernet port, connect the RJ-45 port via a Category 5 or better Ethernet cable to a 10/100Mbps Ethernet device. The Ethernet port is configured for Auto-Negotiation with a maximum through-put of 65Mbps.

### LED Indicators

The T1/E1 MUX operates in a bookend configuration. Each T1/E1 MUX must have the same physical configuration. During initialization, the MUX maps the modules and ports, creating a symmetrical pairing between the MUXes.

#### 4xT1/E1 MUX Module

Each T1/E1 MUX module has LEDs to indicate the status of the connection between the MUXes and the local and remote T1/E1 signals.

LED Legend	Function	Color
Pwr	Power	Green
Sys	Local System Status	Green/Amber
Lnk	Port Local Link T1/E1 Status LED	Green/Amber
Rmt	Port Remote Link T1/E1 Status LED	Green/Amber
Stat	Remote System Status	Green/Amber

#### LED Indicators

The Sys LED indicates the status of the local 4xT1/E1 MUX module. A solid green LED indicates normal system status. A blinking LED indicates different testing scenarios.

The Stat LED indicates the status of the remote 4xT1/E1 MUX module. A solid green LED indicates normal remote system status. A blinking green LED indicates the remote 4xT1/E1 MUX module has not synchronized with the local module or synchronization has started but not completed.

The Lnk LED indicates the local status of the T1/E1 signal. A solid green LED indicates a good T1/E1 signal is detected by the port. A blinking green LED indicates the port is not detecting the T1/E1 signal (a T1 crossover cable may be required). A solid amber LED indicates the port is receiving an AIS signal. A blinking yellow LED indicates a test condition.

The Rmt LED indicates the remote status of the T1/E1 signal. A solid green LED indicates a good T1/E1 signal is detected by the port. A blinking green LED indicates a synchronization problem. A solid amber LED indicates the port is receiving an AIS signal or the port is in local loopback.

LED	Function
Lnk	<b>OFF:</b> Loss of power or the Port Alarm Relay/LED switch is disabled <b>Solid Green:</b> Local connection detected <b>Blinking Green:</b> Local port LoS (RED Alarm) <b>Solid Amber:</b> Local port receiving AIS <b>Blinking Amber:</b> Local port in T1/E1 copper loopback mode
Rmt	<b>OFF:</b> Loss of power or the Port Alarm Relay/LED switch is disabled <b>Solid Green:</b> Remote T1/E1 port connected <b>Blinking Green:</b> Remote T1/E1 port not connected or not synchronized <b>Solid Amber:</b> Remote T1/E1 port connected but receiving LoS, AIS or port in local loopback
Lnk and Rmt (all ports)	<b>Sequential Pattern (left to right) Amber to Green:</b> T1/E1 MUX/M Initializing

#### Lnk and Rmt LED Indicators

LED Indicator		Function	
Sys	Stat	Local	Remote
Off	Off	No power	N/A
Green - ON	Green - 1Hz	Normal	Not peered with remote (searching)
	Green - 5Hz	Normal	Peering started with remote, but not complete
	Green - ON	Normal	Peered with remote
	Amber - 5Hz	Normal	Remote MUX T1/E1 operation mismatch (one set to T1 and the other MUX set for E1)
Amber - ON	Green - 1Hz	Local fiber loopback	Not peered with remote MUX (searching)
	Green - 5Hz	Local fiber loopback	Peering started, not completed with remote
	Green - ON	Local fiber loopback	Peered with remote MUX
Amber - 1Hz	Green - 1Hz	Remote fiber loopback initiated	Not peered with remote MUX (searching); loopback failed
	Green - 5Hz	Remote fiber loopback initiated	Peering started, but not completed with remote MUX; loopback failed
	Green - ON	Remote fiber loopback initiated	Peered with remote MUX; loopback okay
	Amber - ON	Remote fiber loopback initiated	Peered with remote MUX; loopback failed
Amber - 5Hz	Green - ON	Responding to remote fiber loopback	Peered with remote MUX; loopback okay
	Amber - ON	Responding to remote fiber loopback	Peered with remote MUX; loopback refused [possible if Copper Loopback is active]
Alternating Green & Amber 1Hz	Green - 5Hz	Circuit Test (test head) initiated	Peering started, but not completed with remote MUX; circuit test failed
	Green - ON	Circuit Test (test head) initiated	Peered with remote MUX; circuit test okay
	Amber - ON	Circuit Test (test head) initiated	Peered with remote MUX; circuit test failed. LED will turn GREEN when the link is fixed.
Alternating Green & Amber 5Hz	Green - ON	Responding to Circuit Test (comparator)	Peered with remote Mux; circuit test okay
	Amber - ON	Responding to Circuit Test (comparator)	Peered with remote Mux; circuit test failed. LED will turn GREEN when the link is fixed.

#### Sys and Stat LED Indicators

## Fiber Transport Module

Verify the LEDs per the table below.

LED Function "Legend"	Color	Description
Power "PWR"	Green	<b>OFF:</b> No power applied <b>ON:</b> Module has power
Power "PS1", "PS2", "PS3"	Green	<b>N/A</b>
P1 Link Activity "FO"	Green	<b>OFF:</b> Fiber port not linked <b>ON:</b> Fiber link is active <b>Blinking (0.5 Hz):</b> SFD error detection <b>Blinking (10 Hz):</b> Data activity
P2 Speed "10"	Green	<b>OFF:</b> Port not linked at 10Mbps <b>ON:</b> Active 10Mbps link <b>Blinking (0.5 Hz):</b> SFD error detection <b>Blinking (10 Hz):</b> Data activity
P2 Speed "100"	Green	<b>OFF:</b> Port not linked at 100Mbps <b>ON:</b> Active 100Mbps link <b>Blinking (0.5 Hz):</b> SFD error detection <b>Blinking (10 Hz):</b> Data activity
P2 Duplex "FDX"	Green	<b>OFF:</b> Half-duplex <b>ON:</b> Full-duplex

Fiber Transport Module LED Indicators

## Mechanical

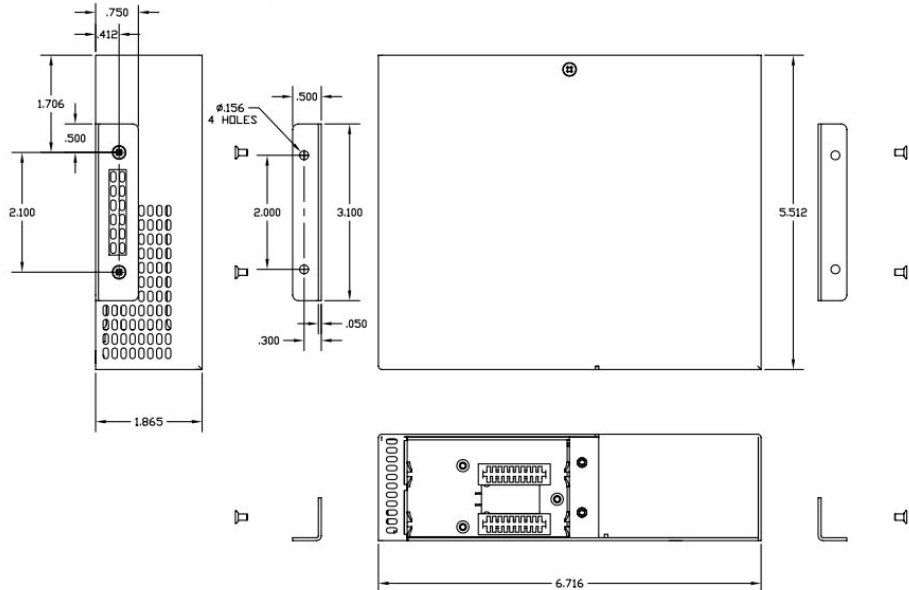

## Specifications

<b>Data Rates</b>	T1: 1.544Mbps ISDN PRI: 1.544Mbps E1: 2.048Mbps Ethernet: 10/100 (65Mbps max)
<b>Standard Compliances</b>	ANSI: T1.403, T1.102, AT&T: T62411, ITU: G.703, G.704, G.706, G.736, G.755, G.823, G.824, G.8261, ETSI: ETS 300 166, IEEE 802.3
<b>Regulatory Compliances</b>	Safety: UL, CE, UKCA EMI: FCC Class A ACT: TAA, BAA, NDAA
<b>Environmental</b>	RoHS, WEEE, REACH
<b>Frame Size</b>	Up to 2,044 bytes for Ethernet
<b>Port Types</b>	Copper: T1/E1 (RJ-45/RJ-48); 10/100BASE-T (RJ-45) Fiber: ST, SC, Single-fiber SC, SFP (100Mbps)
<b>Cable Types</b>	Copper: Cat 3 or Higher for T1/E1 (T1: 100 Ω, E1: 120 Ω) (Active Pairs are Pins 1, 2 and 4, 5) EIA/TIA 568A/B, Cat 5 UTP and higher for Ethernet Fiber: Multimode: 50/125μm, 62.5/125μm Single-mode: 9/125μm
<b>AC Power Requirements</b>	AC Input: 100 to 240VAC 50/60Hz, 0.5A @ 120VAC IEC 320 Socket
<b>DC Power Requirements</b>	DC Input: 18 to 60VDC; 2.0A @ 48VDC 3-Pin Terminal (isolated)
<b>Alarm Contact</b>	Normally Open Form A relay (pins 7 and 8)
<b>Dimensions W x D x H</b>	6.7" x 5.51" x 1.87" (170.18 mm x 139.95 mm x 47.5 mm)
<b>Weight</b>	2.5 lb (1.14 kg)
<b>Temperature</b>	Commercial: 0 to 50°C Wide: -40 to 60°C Extended: -40 to 75°C Storage: -40 to 80°C
<b>Humidity</b>	5 to 95% (non-condensing)
<b>Altitude</b>	-100m to 4,000m
<b>MTBF (hrs)</b>	AC Models - 150,000 DC Models- 165,000
<b>Warranty</b>	Lifetime warranty with 24/7/365 free Technical Support

## General and Copyright Notice

This publication is protected by U.S. and international copyright laws. All rights reserved. The whole or any part of this publication may not be reproduced, stored in a retrieval system, translated, transcribed, or transmitted, in any form, or by any means, manual, electric, electronic, electromagnetic, mechanical, chemical, optical or otherwise, without prior explicit written permission of Omnitron Systems Technology, Inc.

The following trademarks are owned by Omnitron Systems Technology, Inc.: FlexPoint™, FlexSwitch™, iConverter®, miConverter™, NetOutlook®, OmniLight®, OmniConverter®, RuggedNet®, Omnitron Systems Technology, Inc.™, OST™ and the Omnitron logo.

All other company or product names may be trademarks of their respective owners.

The information contained in this publication is subject to change without notice. Omnitron Systems Technology, Inc. is not responsible for any inadvertent errors.

## Warranty

This product is warranted to the original purchaser (Buyer) against defects in material and workmanship for a period of two (2) years from the date of shipment. A lifetime warranty may be obtained by the original purchaser by registering this product at [www.omnitron-systems.com/support](http://www.omnitron-systems.com/support) within ninety (90) days from the date of shipment. During the warranty period, Omnitron will, at its option, repair or replace a product which is proven to be defective with the same product or with a product with at least the same functionality.

For warranty service, the product must be sent to an Omnitron designated facility, at Buyer's expense. Omnitron will pay the shipping charge to return the product to Buyer's designated US address using Omnitron's standard shipping method.

## Limitation of Warranty

The foregoing warranty shall not apply to product malfunctions resulting from improper or inadequate use and/or maintenance of the equipment by Buyer, Buyer-supplied equipment, Buyer-supplied interfacing, unauthorized modifications or tampering with equipment (including removal of equipment cover by personnel not specifically authorized and certified by Omnitron), or misuse, or operating outside the environmental specification of the product (including but not limited to voltage, ambient temperature, radiation, unusual dust, etc.), or improper site preparation or maintenance.

No other warranty is expressed or implied. Omnitron specifically disclaims the implied warranties of merchantability and fitness for any particular purpose.

The remedies provided herein are the Buyer's sole and exclusive remedies. Omnitron shall not be liable for any direct, indirect, special, incidental, or consequential damages, whether based on contract, tort, or any legal theory.

## Environmental Notices

The equipment covered by this manual must be disposed of or recycled in accordance with the Waste Electrical and Electronic Equipment Directive (WEEE Directive) of the European Community directive 2012/19/EU on waste electrical and electronic equipment (WEEE) which, together with the RoHS Directive 2015/863/EU, for electrical and electronic equipment sold in the EU after July 2019. Such disposal must follow national legislation for IT and Telecommunication equipment in accordance with the WEEE directive: (a) Do not dispose waste equipment with unsorted municipal and household waste. (b) Collect equipment waste separately. (c) Return equipment using collection method agreed with Omnitron.

The equipment is marked with the WEEE symbol shown to indicate that it must be collected separately from other types of waste. In case of small items the symbol may be printed only on the packaging or in the user manual. If you have questions regarding the correct disposal of equipment go to [www.omnitron-systems.com/support](http://www.omnitron-systems.com/support) or e-mail to Omnitron at [intlinfo@omnitron-systems.com](mailto:intlinfo@omnitron-systems.com).



## Safety Warnings and Cautions



ATTENTION: Observe precautions for handling electrostatic discharge sensitive devices.



WARNING: Potential damage to equipment and personal injury.



WARNING: Risk of electrical shock.

## CUSTOMER SUPPORT INFORMATION

Phone: (949) 250-6510

Fax: (949) 250-6514

Address: Omnitron Systems Technology, Inc.  
38 Tesla  
Irvine, CA 92618, USA

Email: [support@omnitron-systems.com](mailto:support@omnitron-systems.com)

URL: [www.omnitron-systems.com](http://www.omnitron-systems.com)