

iConverter® 2GXM2

Gigabit Ethernet Fiber-to-Fiber Converter/Transponder and Network Interface Device

The iConverter 2GXM2 is a carrier-grade Network Interface Device (NID) that provides Gigabit Ethernet fiber to fiber conversion with integrated management. The 2GXM2 feature pluggable transceiver ports, and can be used as fiber mode converters, CWDM or DWDM transponders, or fiber repeaters supporting the three Rs (regeneration, retiming and reshaping).

For Service Providers, the 2GXM2 NID provides MEF 9, 14 and 21 certified demarcation of Carrier Ethernet E-Line services.

For Enterprise and Government and Utility networks, the 2GXM2 enables secure demarcation and management for mission-critical applications delivered over fiber infrastructure.

The integrated management eliminates the cost and space required for external management hardware. The integrated management provides comprehensive remote configuration and performance monitoring.

The 2GXM2 supports IPv4 addressing, IP-Less protocol using the 802.3ah OAM channel or using SNMPv1/v2c/v3, Telnet or serial console port.

The IP address is user-defined or can be resolved through DHCP. Telnet and serial console (CLI) management interfaces are also supported, and utilize an easy-to-use, menu-driven interface. The CLI interface provides local configuration access.

SNMP management is available via Omnitron's NetOutlook® SNMP Network Management Software with an intuitive Graphical User Interface, or third party SNMP software.

The 2GXM2 Small Form Pluggable (SFP) model supports a wide variety of SFP transceivers for FTTX, CWDM and DWDM applications. SFP fiber transceivers are available with multimode dual fiber, single-mode dual fiber and single-mode single-fiber options. The module supports frame sizes up to 10,240 bytes.

The 2GXM2 features multiple, user-selectable link fault detection modes, including Link Fault Propagation, Remote Fault Detection and Asymmetrical Fault Detection. These Link Modes provide rapid fault detection and isolation by monitoring the state of the fiber ports, and operate independently of the network management.

The 2GXM2 is available as compact, managed standalone units, or chassis plug-in modules. The plug-in module can manage other modules in the same chassis and operate as a managed fiber-to-fiber media converter.



SFPs not included

KEY FEATURES

- Carrier-Grade optical Ethernet Network Interface Device
- Can be used as fiber mode converters, CWDM or DWDM transponders, or fiber repeaters supporting the three Rs
- Integrated IPv4, SNMPv1/v2c/v3, Telnet and IP-less 802.3ah management
- SNMP management via NetOutlook® provides real-time port and module status information, configuration and trap notification
- 802.3ah Link OAM for early fault detection and performance monitoring
- Supports Gigabit SFP transceivers for standard, CWDM or DWDM wavelengths
- 10,240 byte Jumbo frames
- Supports 802.1ad Q-in-Q, QoS, Port Access Control and MIB statistics
- Bandwidth control (rate limiting) with 64Kb increments
- Configurable Link Fault Propagation modes
- Automatic Link Recovery
- Commercial (0 to 50°C), wide (-40 to 60°C) and extended (-40 to 75°C) temperature ranges
- MEF 9, 14 and 21 Certified
- NEBS Level 3 Compliant
- TAA, BAA and NDAA compliant, and Made in the USA
- Lifetime Warranty and free 24/7 Technical Support

The hot-swappable plug-in module can be mounted in a high-density 19 or 5-Module chassis with redundant AC and DC power supplies. It can also be mounted in a 2-Module or in a 1-Module chassis with AC or DC power input.

The plug-in module features two Ethernet backplane ports for connectivity to adjacent modules in a chassis for multi-port and multi-service configurations.

The 2GXM2 standalone unit is available with an external AC to DC power adapter or with a 2-pin terminal connector

for direct connection to DC power. The standalone module can be DIN-Rail mounted using the optional DIN-Rail mounting bracket (8250-0), DIN-Rail Mounting Clips (8251-0) and wall mounted.

The 2GXM2 standalone unit combines management capability with a compact chassis for deployment at the demarcation point.

ADDITIONAL FEATURES

IEEE 802.3ah Operations, Administration and Maintenance

The 2GXM2 supports the IEEE 802.3ah Link OAM standard with Fault Detection, Performance Monitoring and Remote Loopback for Ethernet in the First Mile (EFM) access links.

Fault Detection

The 2GXM2 detects and indicates link faults, dying gasp and other critical events. Dying gasp is supported on all standalone models and plug-in models when installed in a 1-Module or 2-Module chassis with dying gasp support. The 2GXM2 also supports Unidirectional Link Fault Detection that indicates faults in either direction of the fiber link.

Performance Monitoring

802.3ah Performance Monitoring tools are used for the detection and notification of link performance (quality) faults. Ethernet data performance can deteriorate slowly over time, and the 2GXM2 allows the setting of error-per-second thresholds with event notification for early indication of issues that may be resolved prior to loss of service.

Remote Loopback

Remote Loopback is used for fault localization and link performance testing. When a 2GXM2 port is in loopback mode, all received link traffic is looped back and transmitted back unaltered. The statistics from the 2GXM2 port and the remote link partner can be compared for consistency.

VLAN with 802.1ad Q-in-Q and QoS for E-Line services

The 2GXM2 supports the IEEE 802.1Q tag VLAN tagging and untagging (including Q-in-Q tunneling and 802.1ad service provider tag) and the 802.1p Quality of Service priority standards.

VLAN 802.1ad tunneling technology enables service providers to offer their customers E-Line services. The 802.1p Quality of Service (QoS) prioritization enables delivery of high-priority, real-time applications such as voice and video over Ethernet.

Port Bandwidth Control and Port Access Control

The enhanced Bandwidth Control feature controls bandwidth between the fiber and RJ-45 ports in 64Kbps increments from 64K to Full Line Speed.

The 2GXM2 features Port Access Control which blocks user service while maintaining the network link. Port Access Control enables for easy disabling or enabling of customer service and provides the capability to improve network security by controlling port access when the port is not in use.

Port Statistics and Optical Performance Statistics

The 2GXM2 supports reporting of utilization, port and optical performance statistics. Additionally, full optical performance statistics are available on SFP fiber transceivers with a digital diagnostic interface.

Port and optical performance statistics reporting provides the ability to monitor customer bandwidth utilization, network performance and the link signal quality for each individual port.

APPLICATIONS

Secure IP-less Management

iConverter 2GXM2 plug-in modules are installed in the 19-Module chassis, and connected via the fiber link to a standalone GXTM2 module. An Network Management Module (NMM2) is installed in the 19-Module chassis providing an IP-less management channel between the link partners. The management data is encrypted and isolated from the customer data, protecting the management from unauthorized access. The IP address for this chassis configuration reside only on the NMM2, and does not exist on the customer network.

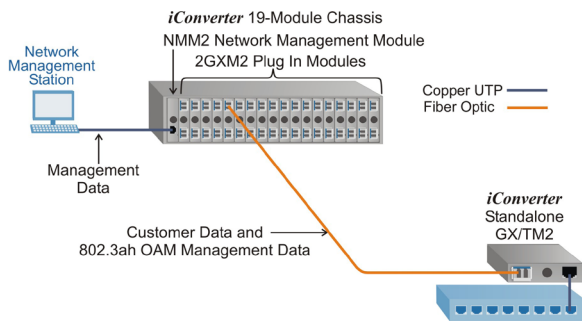

Securely Managed Access Network

iConverter 2GXM2 plug-in modules are installed in a managed iConverter 19-Module chassis for high-density fiber distribution. At Customer Premises on the right, a 2GXM2 plug-in module and an iConverter 4GT four-port switch module are installed in a 2-Module chassis, and share data via the Ethernet Backplane. This configuration provides a remotely managed demarcation switch with a fiber uplink port and five copper ports that drop off Ethernet services. At Customer Premises on the left, the 2GXM2 standalone NID provides two fiber uplink ports for intelligent demarcation of Ethernet services.

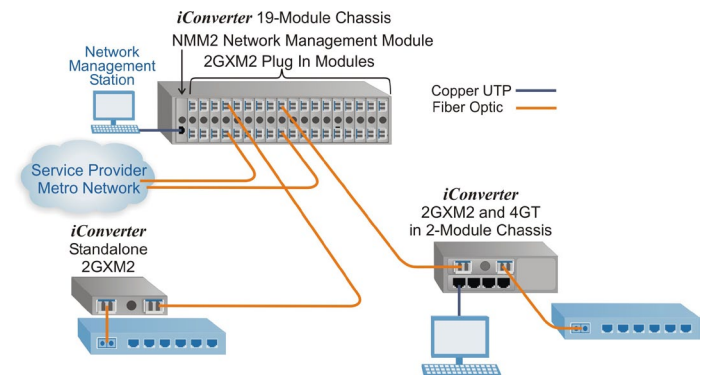

SPECIFICATIONS

| | | |
|-------------------------------|---|--|
| Description | iConverter 2GXM2 Gigabit Ethernet Fiber-to-Fiber Converter/Transponder and Network Interface Device | |
| Standard Compliances | IEEE 802.3, 802.1Q, 802.1p, 802.1ad, 802.3ah RFC 2819 (RMON), 2863, 2131 MEF 9, 14, 21 | |
| Regulatory Compliances | Safety: EMI: ACT: | UL, cUL, CE, NEBS Level 3, UKCA FCC Class A TAA, BAA, NDAA |
| Environmental | RoHS, WEEE, REACH | |
| Port Types | Fiber: Serial: | 1000BASE-X Dual Fiber (SFP) 1000BASE-BX Single-Fiber (SFP) RS-232 (Mini DIN-6 female) Mini DIN-6 to DB-9 adapter included |
| Cable Types | Fiber: Serial: | Multimode: 50/125µm, 62.5/125µm Single-mode: 9/125µm RS-232, 22 to 24 AWG, 12 to 50 pF/ft |
| AC Power Requirements | AC Adapter: (US) AC Adapter: (Universal) | 100 - 240VAC/50 - 60Hz 0.05A @ 120VAC (max) 100 - 240VAC/50 - 60Hz 0.05A @ 120VAC (max) |
| DC Power Requirements | DC Input: (Backplane) DC Input: (Terminal Block) DC Input: (AC Adapter) | 3.3VDC, 1.1A @ 3.3VDC +8 to +15VDC, 0.6A @ 9VDC 2-Pin Terminal (non-isolated) +8 to +15VDC, 0.6A @ 9VDC 2.5mm Barrel Connector |

| | | |
|-----------------------------|--|---|
| Management | IPv4, Telnet, SNMPv1, SNMPv2c, SNMPv3, Serial Console | |
| Frame Size | Up to 10,240 bytes | |
| Dimensions W x D x H | Plug-in: Standalone: w/mounting brackets: | 0.85" x 4.5" x 2.8" (21.6 mm x 114.3 mm x 71.1 mm) 3.1" x 4.8" x 1.0" (78.74 mm x 121.92 mm x 25.4 mm) 3.8" x 4.8" x 1.0" (96.5 mm x 121.9 mm x 25.4 mm) |
| Weight | Plug-in: Standalone w/o Adapter: Standalone w Adapter: | 8 oz. (226.8 grams) 1.0 lb. (453.6 grams) 1.5 lbs. (680.4 grams) |
| Temperature | Commercial: Wide: Extended: Storage: | 0 to 50°C -40 to 60°C -40 to 75°C -40 to 80°C |
| Humidity | 5 to 95% (non-condensing) | |
| Altitude | -100m to 4,000m | |
| MTBF (hrs) | Plug-in: Standalone w/o Adapter: Standalone w/ US Adapter: Standalone w/ Uni Adapter: | 540,000 540,000 250,000 100,000 |
| Warranty | Lifetime warranty with 24/7/365 free Technical Support | |



ORDERING INFORMATION

Step 1: Choose a Base Part Number (8999N-0-pt)

| Model Number | Description |
|--------------|---|
| 8999N-0-pt | iConverter 2GXM2 Gigabit Ethernet Fiber-to-Fiber Converter/Transponder and Network Interface Device |

Contact Omnitron for other configurations.
Order the appropriate Gigabit Ethernet SFPs separately. [Visit the Omnitron Optical Transceivers web page](#) or see the below table.
For chassis options, see [iConverter Chassis Overview web page](#).

Step 2: Choose a Power Option (8999N-0-pt)

| |
|---|
| <leave blank> = Plug-in module |
| A = Barrel Connector and AC/DC Power Adapter, 100-240VAC, 50-60Hz, with US power cord without integrated mounting brackets |
| B = Barrel Connector and Universal AC/DC Adapter, 100-240 VAC, 50-60Hz, No Power Cord, without integrated mounting brackets |
| C = Direct DC input, 2 pin terminal connector, no AC/DC power adapter, without integrated mounting brackets |
| D = Barrel Connector and AC/DC Power Adapter, 100-240VAC, 50-60Hz, with US power cord with integrated mounting brackets |
| E = Barrel Connector and Universal AC/DC Adapter, 100-240 VAC, 50-60Hz, No Power Cord, with integrated mounting brackets |
| F = Direct DC input, 2 pin terminal connector, no AC/DC power adapter, with integrated mounting brackets |

Step 3: Choose an Operating Temperature Range (8999N-0-pt)

| |
|--|
| <leave blank> = Commercial temperature (0 to 50°C) |
| W = Wide temperature (-40 to 60°C) |
| Z = Extended temperature (-40 to 75°C) |

ACCESSORIES

| Model Number | Description |
|--------------|---|
| 8250-0 | DIN Rail Mounting Bracket for standalone modules without integrated mounting brackets (power option -A, -B, -C) |
| 8251-0 | DIN Rail Mounting Clip for standalone models with integrated mounting brackets (power options -D, -E, -F) |
| 8260-0 | 1U Rack Mount Shelf for standalone models (up to 4 modules) |

For more information on the variety of SFPs available, visit Omnitron's web site at: www.omnitron-systems.com

| Model | Fiber Type | Spec. Distance (km) | Tx / Rx Wavelength (nm) | Min. Tx Power (dBm) | Max. Tx Power (dBm) | Min. Rx Power (dBm) | Max. Rx Power (dBm) | Min. Attenuation (dB) | Link Budget (dB) |
|--------|--------------------|-------------------------|-------------------------|---------------------|---------------------|---------------------|---------------------|-----------------------|------------------|
| 7206-0 | MM/DF | 220 / 550m ¹ | 850 / 850 | -9.5 | -4 | -17 | -3 | - | 7.5 |
| 7206-6 | MM/DF | 2 | 1310 / 1310 | -9.5 | -3 | -19.5 | -3 | - | 10 |
| 7207-1 | SM/DF | 15 | 1310 / 1310 | -9.5 | -3 | -21 | -3 | - | 11.5 |
| 7207-2 | SM/DF | 34 | 1310 / 1310 | -5 | 0 | -24 | -3 | 3 | 19 |
| 7207-3 | SM/DF | 80 | 1550 / 1550 | -4 | 1 | -24 | -3 | 4 | 20 |
| 7207-4 | SM/DF | 110 | 1550 / 1550 | 0 | 5 | -24 | -3 | 8 | 24 |
| 7207-5 | SM/DF | 140 | 1550 / 1550 | 2 | 5 | -30 | -8 | 13 | 32 |
| 7207-6 | SM/DF | 160 | 1550 / 1550 | 1 | 5 | -33 | -8 | 13 | 34 |
| 7214-1 | SM/SF ² | 20 | 1310 / 1550 | -9 | -3 | -21 | -3 | - | 12 |
| 7215-1 | SM/SF ² | 20 | 1550 / 1310 | -9 | -3 | -21 | -3 | - | 12 |
| 7214-2 | SM/SF ² | 40 | 1310 / 1550 | -3 | 2 | -23 | -3 | 5 | 20 |
| 7215-2 | SM/SF ² | 40 | 1550 / 1310 | -3 | 2 | -23 | -3 | 5 | 20 |

¹ 62.5/125µm, 100/140µm multimode fiber up to 220m. 50/125µm multimode fiber up to 550m.
² Single-fiber (SF) media converter are used in pairs. The Tx wavelength on one end has to match the Rx wavelength on the other.
MM = Multimode, SM = Single-mode, DF = Dual Fiber, SF = Single-fiber

© 2025 Omnitron Systems Technology, Inc. All rights reserved. iConverter and NetOutlook are Registered Trademarks of Omnitron Systems Technology, Inc. Trademarks are owned by their respective companies. Specifications are subject to change without notice.

