

iConverter® Cable Management Kit for 5-Module Chassis Installation Guide

Product Overview

The iConverter Cable Management Kit organizes the routing of fiber and copper cables providing a secure, clean and orderly installation. The Cable Management Kit is used with the iConverter 5-Module Chassis.

Cable Management Kit consists of the following items:

- Cable Tray with six cable clips
- Two extended L-shaped mounting brackets with eight 1/4" 4-40 flat head machine screws
- Four rack mounting screws 1/2" 10/32 truss head machine screws
- 23" mounting bracket (included with the 8096-2 kit only)

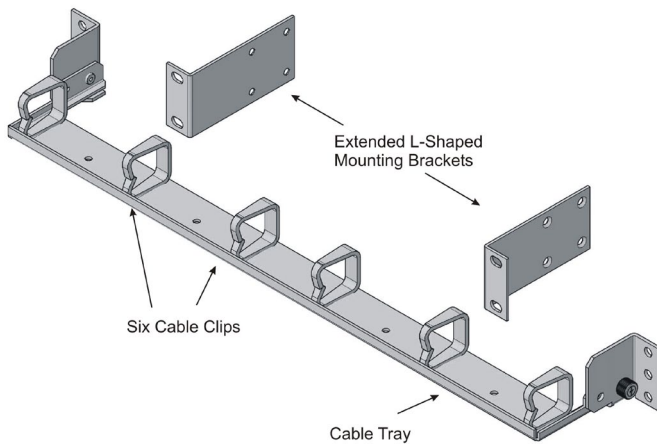

Installation Procedure

- 1) Install/Remove Cable Clips
- 2) Install Extended L-Shaped Mounting Brackets
- 3) Install Cable Management Tray
- 4) Cable Management Tray Operation

1) INSTALL/REMOVE CABLE CLIPS

To install the Cable Clips on the Cable Tray, push the pin located on the bottom of the Cable Clip into the hole on the Cable Tray until the pin is fully inserted.

To remove the Cable Clips, pinch the barbs on the pin located on the bottom of the Cable Clip and pull up on the Cable Clip.

2) INSTALL EXTENDED L-SHAPED MOUNTING BRACKETS

New Installation

Install the extended L-shaped mounting brackets to the sides of the 5-Module chassis as illustrated in the Figure 1. Use the screws included in the Cable Management Kit.

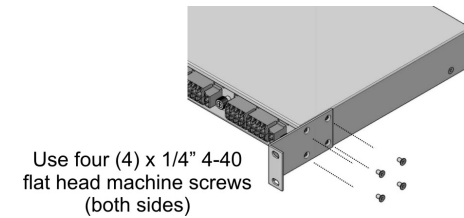

Figure 1: Installation of Extended Mounting Brackets

After the brackets are secured to the chassis, rack-mount the chassis and Cable Tray to the equipment rack per Step 3.

Upgraded Installation

On an existing 5-Module chassis with standard mounting brackets, remove and replace the standard mounting brackets with the extended L-shaped mounting brackets. Remove the four (4) screws securing the standard mounting bracket to the chassis as illustrated in Figure 2.

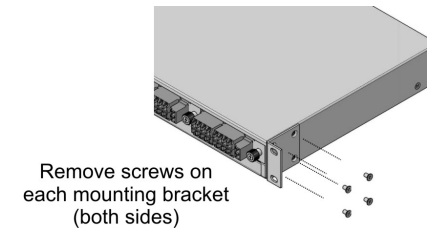

Figure 2: Removal of Standard Mounting Brackets

Install the new extended L-shaped mounting bracket as illustrated in Figure 1. Use the screws included in the Cable Management Kit. After the brackets are secured to the chassis, rack-mount the chassis and Cable Tray to the equipment rack per Step 3.

3) INSTALL CABLE MANAGEMENT TRAY

The Cable Tray and 5-Module Chassis uses the same equipment rack mounting hole. Provide proper support while mounting the Cable Tray and 5-Module Chassis to the equipment rack. Secure the Cable Tray and 5-Module Chassis to the equipment rack using the rack mount screws included in the Cable Management Kit as illustrated in Figure 3.

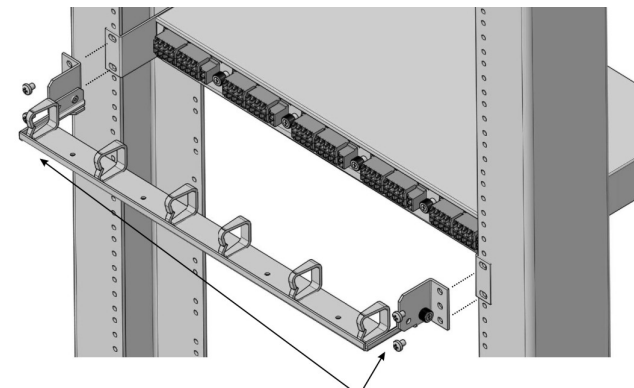

Figure 3: Cable Tray Installation

4) CABLE MANAGEMENT TRAY OPERATION

Modules can be inserted and/or removed from the chassis by loosening the thumbscrews and swinging the Cable Tray downwards as illustrated in Figure 4.

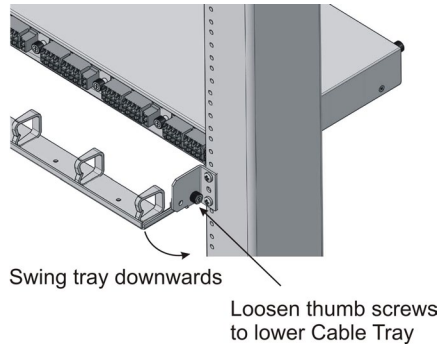

Figure 4: Cable Tray Operation

Fiber optic and copper cables are routed through the cable clips on the Cable Tray. Cables can be routed through both ends of the Cable Tray to maximize the number of installed cables. A service loop in all cables must be provided to allow the Cable Tray to swing downwards.

Installation Procedure for 23" Rack Mount

The iConverter Cable Management Kit (8096-2) provides equipment installation to 23 inch equipment racks. 23" mounting brackets are included to extend the Cable Tray and 5-Module Chassis to accommodate the 23" equipment rack as illustrated in Figure 5.

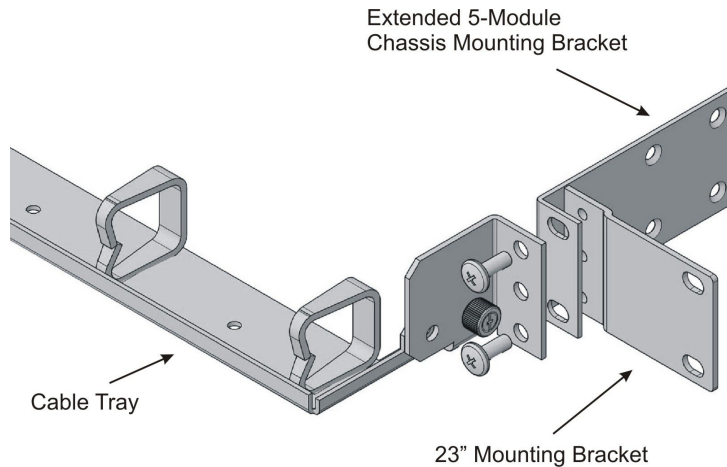

Figure 5: 23" Mounting Bracket Installation

Install the extended L-shaped mounting brackets to the 5-Module Chassis per Step 2.

As illustrated in the figure above, the 23" mounting bracket is installed on the back side of the extended L-shaped mounting brackets.

Install the 23" mounting bracket to the equipment rack. Install the Cable Tray and 5-Module Chassis to the 23" mounting bracket as illustrated in Figure 6. Provide proper support while mounting the Cable Tray and 5-Module Chassis to the 23" mounting bracket. Secure the Cable Tray and 5-Module Chassis to the equipment rack using the rack mount screws included in the Cable Management Kit.

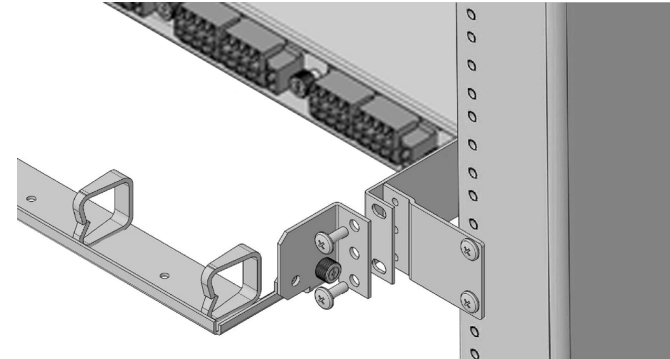

Figure 6: 23" Cable Tray Installation

Environmental Notices

The equipment covered by this manual must be disposed of or recycled in accordance with the Waste Electrical and Electronic Equipment Directive (WEEE Directive) of the European Community directive 2012/19/EU on waste electrical and electronic equipment (WEEE) which, together with the RoHS Directive 2015/863/EU, for electrical and electronic equipment sold in the EU after July 2019. Such disposal must follow national legislation for IT and Telecommunication equipment in accordance with the WEEE directive: (a) Do not dispose waste equipment with unsorted municipal and household waste. (b) Collect equipment waste separately. (c) Return equipment using collection method agreed with Omnitron.



The equipment is marked with the WEEE symbol shown to indicate that it must be collected separately from other types of waste. In case of small items the symbol may be printed only on the packaging or in the user manual. If you have questions regarding the correct disposal of equipment go to www.omnitron-systems.com/support or e-mail to Omnitron at intlinfo@omnitron-systems.com.

Customer Support Information

Phone: (949) 250-6510
Fax: (949) 250-6514
Address: Omnitron Systems
38 Tesla
Irvine, CA 92618 USA
E-mail: support@omnitron-systems.com
URL: <http://www.omnitron-systems.com>