

FlexPoint® GX/T

10/100/1000 Copper to 100/1000X Fiber Ethernet Media Converter

The FlexPoint GX/T is a 10/100/1000BASE-T copper to 1000BASE-X fiber media converter that supports jumbo frames up to 10,240 bytes. The GX/T features Small Form Pluggable (SFP) transceivers that support both 100BASE-FX and 1000BASE-X for interoperability with Gigabit and Fast Ethernet fiber equipment. SFP transceivers enable adaptability to different fiber types, speed and distances, and support CWDM and DWDM wavelengths.

The FlexPoint GX/T fixed fiber models support 1000BASE-X over multimode and single-mode dual fiber with ST, SC and LC connectors; and single-mode single-fiber with SC connectors.

Both the fiber port and the RJ-45 port support auto-negotiation to achieve the best possible mode of operation (speed, duplex mode and Pause mode) between the devices. The auto-negotiation feature can be disabled on both ports (for manual configuration) using DIP-switches on the product. This is useful in a situation where the GX/T is connected to a non-negotiating device and the configuration parameters must be set manually.

Network flow control is managed by the Pause function (configured via auto-negotiation or manually) that prevents network congestion on both the RJ-45 and fiber ports. When Pause is enabled and the device is experiencing network congestion, it will send out a Pause signal to its link partner, instructing it to slow down data transmission.

A variety of testing and fault detection tools are provided for easy installation and troubleshooting. The GX/T supports Port Loop-Back, IEEE defined Far-End-Fault and Link Fault bit as Remote Fault indicators. The GX/T generates a remote fault indicator when it detects link fault conditions, and reports detection of these signals by displaying status on the LED. Through user DIP-switch configuration, the detection of these indicators or link modes can also be propagated to the other port on the GX/T as a means of notifying connected end-devices of the link fault.

Diagnostic status LED indicators assist in network installation and maintenance. The LEDs report the availability of power, port activity and link status and duplex mode.

The GX/T supports a wide input voltage range of 5 to 32VDC for flexibility to power the device from a variety of sources.

GX/T modules can be standalone or surface-mounted utilizing optional wall-mounting hardware or DIN-rail mounting brackets. They can also be rack-mounted in a 5-Module shelf or in a high-density 14-Module, power-redundant chassis.



SFPs not included

KEY FEATURES

- 10/100/1000 copper to 100/1000* fiber media converter
- Conforms to 10BASE-T, 100BASE-TX, 1000BASE-T, 100BASE-FX* and 1000BASE-X specifications
- Fixed fiber port supports multimode and single-mode dual fiber with ST, SC and LC connectors; and single-mode single-fiber with SC connectors
- Supports 100Mbps and 1Gbps SFP transceivers for standard, CWDM or DWDM wavelengths
- Both the fiber and RJ-45 ports support auto-negotiation
- Provides Far-End Fault and Link Fault modes
- RJ-45 port supports 10/100/1000Mbps, Half/Full-Duplex, configurable Pause function for flow control and MDI/MDIX auto-crossover
- Supports jumbo frames up to 10,240 bytes
- Loopback mode supports end-to-end testing
- User-selectable Link Modes for quick fault detection
- Automatic Link Recovery
- Diagnostic and DIP-switch configurations are displayed with status LEDs for quick and easy installation
- Tabletop, wall-mounted, rack-mounted in a 5-Module shelf or in a 14-Module power-redundant chassis options
- Commercial (0 to 50°C) and wide (-40 to 60°C) temperature ranges
- TAA, BAA and NDAA compliant, and Made in the USA
- Lifetime Warranty and free 24/7 Technical Support

* 100BASE-FX is supported on SFP models only

SPECIFICATIONS

Description	FlexPoint GX/T 10/100/1000BASE-T Copper to 100BASE-FX/1000BASE-X Fiber Media Converter		
Standard Compliances	IEEE 802.3		
Regulatory Compliances	Safety:	UL, cUL, CE, UKCA	
	EMI:	FCC Class A	
	ACT:	TAA, BAA, NDAA	
Environmental	RoHS, WEEE, REACH		
Frame Size	Up to 10,240 bytes		
Port Types	Copper:	10/100/1000BASE-T (RJ-45)	
	Fiber:	100BASE-FX (SFP) 1000BASE-X (ST, SC, LC, SFP)	
Cable Types	Copper:	EIA/TIA 568A/B, Cat 5 UTP and higher	
	Fiber:	Multimode: 50/125µm, 62.5/125µm Single-mode: 9/125µm	
AC Power Requirements	AC Adapter:	100 - 240VAC/50 - 60Hz 0.03A @ 120VAC (typical)	
DC Power Requirements	Voltage Range:	Barrel Connector	Molex Connector
	Nominal Voltage:	5.0 to 32VDC	4.75 to 5.25VDC
	Nominal Power:	0.3A @ 9VDC	0.5A @ 5VDC
Dimensions W x D x H	3.0" x 4.0" x 1.0" (76.2 mm x 101.6 mm x 25.4 mm)		
Weight	Without AC Adapter:	6 oz. (170.1 grams)	
Temperature	Commercial:	0 to 50°C	
	Wide::	-40 to 60°C	
	Storage:	-40 to 80°C	
Humidity	5 to 95% (non-condensing)		
Altitude	-100m to 4,000m		
MTBF (hrs)	Without AC Adapter (-0):	900,000	
	With AC Adapter (-1):	250,000	
	With AC Adapter (-2):	100,000	
Warranty	Lifetime warranty with 24/7/365 free Technical Support		

APPLICATION EXAMPLE

In this enterprise application example, FlexPoint GX/T media converters are used to connect to multiple generations of networking components across a campus. A legacy 100 Mbps fiber switch (A) is directly connected to a UTP Gigabit switch using a FlexPoint GX/T with a 100 Mbps SFP transceiver installed. A fiber-to-desktop application (B) uses a FlexPoint GX/T at both ends to provide 10/100/1000 copper to fiber conversion. The FlexPoint GX/T also connects a UTP Gigabit Ethernet switch (C) via fiber back to the main distribution center. In all cases, multimode, single-mode, or single-mode single-fiber can be used.

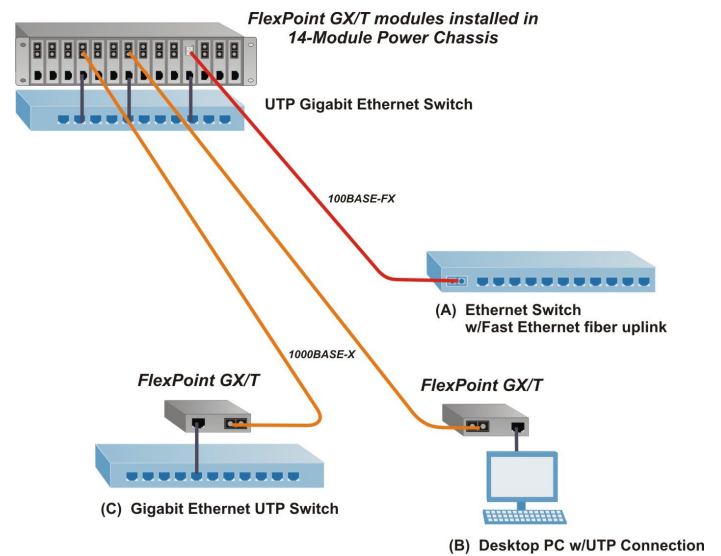

ACCESSORIES

Model Number	Description	Model Number	Description
4380	Wall-Mounting Hardware Kit for Modules	4381	Wall-Mounting Hardware Kit for DC to DC Power Adapter
4384	DC to DC Power Adapter	4384-W	DC to DC Power Adapter, Wide Temperature (-40 to 60°C)
4385	14-Module Chassis with two 48VDC Power Supplies	4386	14-Module Chassis with one 48VDC Power Supply
4389	Spare 48VDC Power Supply	4392	5-Module Rack-Mount Shelf
4395	14-Module Chassis with two AC Power Supplies	4396	14-Module Chassis with one AC Power Supply
4399	Spare AC Power Supply	8250	DIN-Rail Mounting Kit

See all FlexPoint accessories on [FlexPoint Chassis and Mounting Options product page](#)

ORDERING INFORMATION

Step 1: Choose a Base Part Number (xxxx-pt)

Fiber Type	Distance	Connector Type				Tx / Rx Lambda (nm)	Min. Tx Power (dBm)	Max. Tx Power (dBm)	Min. Rx Power (dBm)	Max. Rx Power (dBm)	Min. Attenuation (dB)	Link Budget (dB)
		ST	SC	LC	SFP							
-	-	-	-	-	4719-pt	-	-	-	-	-	-	-
MM	220 / 550m ¹	4706-pt	4700-pt	4714-pt	-	850 / 850	-10	-4	-17	-3	-	7
SM	12km	4707-pt	4701-pt	4715-pt	-	1310 / 1310	-9.5	-3	-19.5	-3	-	10
SM	34km	-	4702-pt	4716-pt	-	1310 / 1310	-5	0	-23	-3	3	18
SM	80km	-	4703-pt	4717-pt	-	1550 / 1550	-5	0	-23	-3	3	18
SM	110km	-	4704-pt	-	-	1550 / 1550	0	5	-24	-3	8	24
SM	140km	-	4705-pt	-	-	1550 / 1550	2	5	-28	-8	13	30
SM-SF ²	20km	-	4710-pt	-	-	1310 / 1550	-9.5	-3	-20	-3	-	10.5
SM-SF ²	20km	-	4711-pt	-	-	1550 / 1310	-9.5	-3	-20	-3	-	10.5
SM-SF ²	40km	-	4712-pt	-	-	1310 / 1550	-3	0	-20	-3	3	17
SM-SF ²	40km	-	4713-pt	-	-	1550 / 1310	-3	0	-20	-3	3	17

¹ 62.5/125µm (OM1) multimode fiber up to 220m. 50/125µm (OM2) multimode fiber up to 550m

² When using single-fiber (SF) media converter models, the Tx wavelength on one end has to match the Rx wavelength on the other.

MM = Multimode, SM = Single-mode, DF = Dual Fiber, SF = Single-fiber

Contact Omnitron for other fiber options, operational temperature ranges and RoHS (5/6) compliant models.

Order the appropriate SFPs separately. [Visit the Omnitron Optical Transceivers web page.](#)

Step 2: Choose a Power Option (xxxx-pt)

-0 = Barrel Connector, No AC/DC Power Adapter
-1 = Barrel Connector and US AC/DC Power Adapter, 100-240 VAC, 50-60Hz
-2 = Barrel Connector and Universal AC/DC Power Adapter, 100-240VAC, 50-60Hz (requires AC power cord)

Step 3: Choose an Operating Temperature Range (xxxx-pt)

<leave blank> = Commercial temperature (0 to 50°C)
W = Wide temperature (-40 to 60°C)



-1 = Barrel Connector and US AC/DC Power Adapter, 100-240 VAC, 50-60Hz



-2 = Barrel Connector and Universal AC/DC Power Adapter, 100-240VAC, 50-60Hz (requires AC power cord)

© 2025 Omnitron Systems Technology, Inc. All rights reserved. FlexPoint is a registered trademark of Omnitron Systems Technology, Inc. Trademarks are owned by their respective companies. Specifications are subject to change without notice.

