

Omniconverter[®]
FPoE/SL



User Manual

General and Copyright Notice

This publication is protected by U.S. and international copyright laws. All rights reserved. The whole or any part of this publication may not be reproduced, stored in a retrieval system, translated, transcribed, or transmitted, in any form, or by any means, manual, electric, electronic, electromagnetic, mechanical, chemical, optical or otherwise, without prior explicit written permission of Omnitron Systems Technology, Inc.

The following trademarks are owned by Omnitron Systems Technology, Inc.: FlexPoint™, FlexSwitch™, iConverter®, miConverter™, NetOutlook®, OmniLight®, OmniConverter®, RuggedNet®, Omnitron Systems Technology, Inc.™, OST™ and the Omnitron logo.

All other company or product names may be trademarks of their respective owners.

The information contained in this publication is subject to change without notice. Omnitron Systems Technology, Inc. is not responsible for any inadvertent errors.

Warranty

This product is warranted to the original purchaser (Buyer) against defects in material and workmanship for a period of two (2) years from the date of shipment. A lifetime warranty may be obtained by the original purchaser by registering this product at www.omnitron-systems.com/support within ninety (90) days from the date of shipment. During the warranty period, Omnitron will, at its option, repair or replace a product which is proven to be defective with the same product or with a product with at least the same functionality.

For warranty service, the product must be sent to an Omnitron designated facility, at Buyer's expense. Omnitron will pay the shipping charge to return the product to Buyer's designated US address using Omnitron's standard shipping method.

Limitation of Warranty

The foregoing warranty shall not apply to product malfunctions resulting from improper or inadequate use and/or maintenance of the equipment by Buyer, Buyer-supplied equipment, Buyer-supplied interfacing, unauthorized modifications or tampering with equipment (including removal of equipment cover by personnel not specifically authorized and certified by Omnitron), or misuse, or operating outside the environmental specification of the product (including but not limited to voltage, ambient temperature, radiation, unusual dust, etc.), or improper site preparation or maintenance.

No other warranty is expressed or implied. Omnitron specifically disclaims the implied warranties of merchantability and fitness for any particular purpose.

The remedies provided herein are the Buyer's sole and exclusive remedies. Omnitron shall not be liable for any direct, indirect, special, incidental, or consequential damages, whether based on contract, tort, or any legal theory.

Environmental Notices

The equipment covered by this manual must be disposed of or recycled in accordance with the Waste Electrical and Electronic Equipment Directive (WEEE Directive) of the European Community directive 2012/19/EU on waste electrical and electronic equipment (WEEE) which, together with the RoHS Directive 2015/863/EU, for electrical and electronic equipment sold in the EU after July 2019. Such disposal must follow national legislation for IT and Telecommunication equipment in accordance with the WEEE directive: (a) Do not dispose waste equipment with unsorted municipal and household waste. (b) Collect equipment waste separately. (c) Return equipment using collection method agreed with Omnitron.



The equipment is marked with the WEEE symbol shown to indicate that it must be collected separately from other types of waste. In case of small items the symbol may be printed only on the packaging or in the user manual. If you have questions regarding the correct disposal of equipment go to www.omnitron-systems.com/support or e-mail to Omnitron at intlinfo@omnitron-systems.com.

Safety Warnings and Cautions



ATTENTION: Observe precautions for handling electrostatic discharge sensitive devices.



WARNING: Potential damage to equipment and personal injury.



WARNING: Risk of electrical shock.

Customer Support Information

If you encounter problems while installing this product, contact Omnitron Technical Support:

Phone: (949) 250-6510
Fax: (949) 250-6514
Address: Omnitron Systems Technology, Inc.
38 Tesla
Irvine, CA 92618, USA
Email: support@omnitron-systems.com
URL: www.omnitron-systems.com

040-09340-001C 11/21

Omniconverter FPoE/SL User Manual

Product Overview

The OmniConverter FPoE/SL media converters with multi-port options provide 10/100BASE-T copper to 100BASE-FX fiber conversion and function as Power-over-Ethernet (PoE) Power Sourcing Equipment (PSE). Port configurations are available in single or dual RJ-45 and SFP ports.

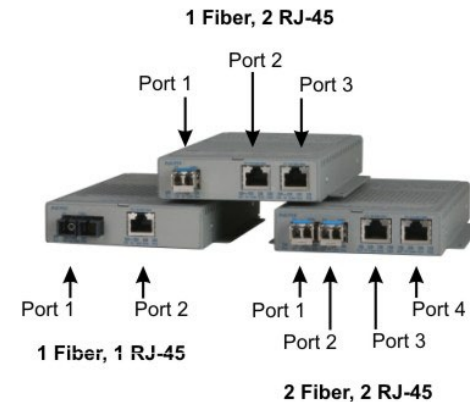

Omniconverter FPoE/SL

Equipment that provides DC power over twisted-pair cable is known as Power Sourcing Equipment (PSE). Equipment that is powered over twisted-pair cable is known as a Powered Device (PD).

The FPoE/SL supports IEEE 802.3af PoE standard and provides up to 15.4W of DC power to each PD.

Installation Procedure

- 1) Configure DIP-switches
- 2) Install the Module
- 3) Apply Power
- 4) Connect Cables
- 5) Verify Operation

1) Configure DIP-switches

DIP-switches are located on the side of the module. The DIP-switches are used to configure ports, link modes and PoE/PSE options.

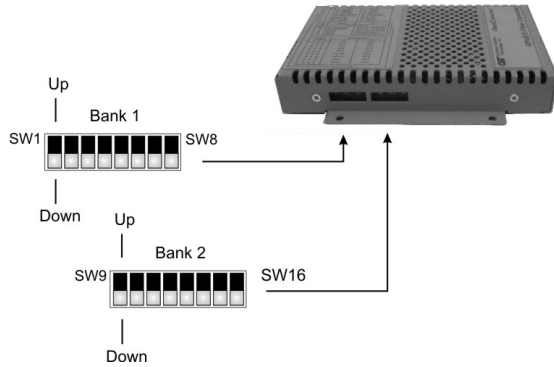

DIP-switch Bank Locations

The table below provides a description of each DIP-switch position and function.

Switch	1 Fiber, 1 RJ-45	1 Fiber, 2 RJ-45	2 Fiber, 1 RJ-45	2 Fiber, 2 RJ-45
1	Port 1 Duplex Mode	Port 1 Duplex Mode	Port 1 Duplex Mode	Port 1 Duplex Mode
2	N/A	N/A	Port 2 Duplex Mode	Port 2 Duplex Mode
3	Port 2 RJ-45 AUTO/MAN	Port 2 RJ-45 AUTO/MAN	Port 3 RJ-45 AUTO/MAN	Port 3 RJ-45 AUTO/MAN
4	Port 2 RJ-45 Speed (Only in MAN mode)	Port 2 RJ-45 Speed (Only in MAN mode)	Port 3 RJ-45 Speed (Only in MAN mode)	Port 3 RJ-45 Speed (Only in MAN mode)
5	Port 2 RJ-45 Duplex (Only in MAN mode)	Port 2 RJ-45 Duplex (Only in MAN mode)	Port 3 RJ-45 Duplex (Only in MAN mode)	Port 3 RJ-45 Duplex (Only in MAN mode)
6	Pause Capability	Pause Capability	Pause Capability	Pause Capability
7	RJ-45 Port 2 PoE/PSE	RJ-45 Port 2 PoE/PSE	RJ-45 Port 3 PoE/PSE	RJ-45 Port 3 PoE/PSE
8	N/A	RJ-45 Port 3 PoE/PSE	N/A	RJ-45 Port 4 PoE/PSE
9	RJ-45 Port 2 Alt A/B	RJ-45 Port 2 Alt A/B	RJ-45 Port 3 Alt A/B	RJ-45 Port 3 Alt A/B
10	N/A	RJ-45 Port 3 Alt A/B	N/A	RJ-45 Port 4 Alt A/B
11	Large Cap Detection	Large Cap Detection	Large Cap Detection	Large Cap Detection
12	Link Mode Selection	Link Mode Selection	Link Mode Selection	Link Mode Selection
13	Link Mode Selection	Link Mode Selection	Link Mode Selection	Link Mode Selection
14	PSE Reset	PSE Reset	PSE Reset	PSE Reset
15	N/A	N/A	Redundant Fiber Link	Redundant Fiber Link
16	N/A	N/A	Return to Port 1	Return to Port 1

DIP-switch Definitions

SW1 and SW2: F/O Duplex “FDX/HDX” DIP-switch

The OmniConverter supports 100BASE-FX SFPs and fixed fiber transceivers. These DIP-switches are used to configure the fiber duplex mode. Setting these DIP-switches to the Up “HDX” position facilitates a connection that supports Half-Duplex. Setting these DIP-switches to the Down “FDX” position facilitates a connection that supports Full-Duplex operation.

SW3, SW4 and SW5 RJ-45 Configuration DIP-Switches

SW3 RJ-45 AN/MAN	SW4 RJ-45 100/10	SW5 RJ-45 FDX/HDX	RJ-45 Mode of Operation
AN	100	FDX	The RJ-45 port is set to auto-negotiation with the following modes advertised: 100FDX, 100HDX, 10FDX, 10HDX
AN	100	HDX	The RJ-45 port is set to auto-negotiation with the following modes advertised: 100HDX, 10FDX, 10HDX
AN	10	FDX	The RJ-45 port is set to auto-negotiation with the following modes advertised: 10FDX, 10HDX
AN	10	HDX	The RJ-45 port is set to auto-negotiation advertising 10HDX.
MAN	100	FDX	The RJ-45 port is set to manual negotiation and is forced to 100FDX.
MAN	100	HDX	The RJ-45 port is set to manual negotiation and is forced to 100HDX.
MAN	10	FDX	The RJ-45 port is set to manual negotiation and is forced to 10FDX.
MAN	10	HDX	The RJ-45 port is set to manual negotiation and is forced to 10HDX.

RJ-45 Port Configuration Matrix

SW6 - Pause “On/Off” DIP-Switch

In auto-negotiation mode, setting this DIP-switch to the Up “On” position allows the unit to advertise Symmetrical and Asymmetrical Pause capability. In auto-negotiation mode, setting the DIP-switch to the Down “Off” position allows the unit to advertise no Pause capability. In the manual mode, this DIP-switch determines the Pause behavior.

SW7 - Power Sourcing Function, RJ-45 Port

The module automatically detects the attached PD and provides the equipment with the necessary power.

This DIP-switch controls the power sourcing function for Port 2 on the single-fiber models and Port 3 on all other models (see DIP-switch Definition table on page 5). When this DIP-switch in the Down “On” position, the power sourcing function is enabled. When the DIP-switch is in the Up “Off” position, the power sourcing function is disabled.

Switch Position	Description	DOWN	UP
7	RJ-45 Port 2 or 3 PoE/PSE	Enabled (ON)	Disabled (OFF)
8	RJ-45 Port 3 or 4 PoE/PSE	Enabled (ON)	Disabled (OFF)

Power Sourcing Function

SW8 - Power Sourcing Function, RJ-45 Port

This DIP-switch controls the power sourcing function for the 2nd RJ-45 port on the 2 RJ-45 port models (see DIP-switch Definition table on page 5). When this DIP-switch in the Down “On” position, the power sourcing function is enabled. When the DIP-switch is in the “Off” UP position, the power sourcing function is disabled.

SW9, SW10 and SW11 - Power Sourcing Modes

The RJ-45 ports can be configured to support different powering modes. The powering modes include Alternative A (supporting power on pins 1,2 and 3,6), Alternative B (supporting power on pins 4,5 and 7,8) and legacy Power Devices (PDs) that use large capacitance for detection.

PoE Modes				
SW9	SW10	SW11	1 Fiber 1 RJ-45	
			Port 2	Port 3
DOWN	N/A	DOWN	IEEE Alt A	IEEE Alt A
UP	N/A	DOWN	IEEE Alt B	IEEE Alt B
DOWN	N/A	UP	Large Capacitor Detection + Alt A	Large Capacitor Detection + Alt A
UP	N/A	UP	Large Capacitor Detection + Alt B	Large Capacitor Detection + Alt B

Power Sourcing Modes for Models with 1 RJ-45 Port

PoE Modes						
SW9	SW10	SW11	1 Fiber 2 RJ-45		2 Fiber 2 RJ-45	
			Port 2	Port 3	Port 3	Port 4
DOWN	DOWN	DOWN	IEEE Alt A	IEEE Alt A	IEEE Alt A	IEEE Alt A
UP	DOWN	DOWN	IEEE Alt B	IEEE Alt A	IEEE Alt B	IEEE Alt A
DOWN	UP	DOWN	IEEE Alt A	IEEE Alt B	IEEE Alt A	IEEE Alt B
UP	UP	DOWN	IEEE Alt B	IEEE Alt B	IEEE Alt B	IEEE Alt B
DOWN	DOWN	UP	Large Capacitor Detection + Alt A	Large Capacitor Detection + Alt A	Large Capacitor Detection + Alt A	Large Capacitor Detection + Alt A
UP	DOWN	UP	Large Capacitor Detection + Alt B	Large Capacitor Detection + Alt A	Large Capacitor Detection + Alt B	Large Capacitor Detection + Alt A
DOWN	UP	UP	Large Capacitor Detection + Alt A	Large Capacitor Detection + Alt B	Large Capacitor Detection + Alt A	Large Capacitor Detection + Alt B
UP	UP	UP	Large Capacitor Detection + Alt B	Large Capacitor Detection + Alt B	Large Capacitor Detection + Alt B	Large Capacitor Detection + Alt B

Power Sourcing Modes for Models with 2 RJ-45 Ports

On devices with two RJ-45 ports, SW11 enables large cap detection on BOTH ports (see table above).

RJ-45 Pinout	PoE Modes	
	Alternative A	Alternative B
1	Vport Positive	
2	Vport Positive	
3	Vport Negative	
4		Vport Positive
5		Vport Positive
6	Vport Negative	
7		Vport Negative
8		Vport Negative

Voltage Polarity for PoE Options

NOTE: Alternative A and Alternative B pinouts are compliant with IEEE802.3af specification.

SW12 and SW13 - Link Modes

The OmniConverter supports Link Segment and Asymmetrical Link Propagate. See Appendix A for Link Mode block diagrams.

Link Segment

In Link Segment mode, all ports operate independently. A loss of a receive link signal will only affect the port detecting the loss of signal. All the other ports will continue to generate a link signal. A loss of link on the RJ-45 port will only affect the RJ-45 port, and the other ports will remain unaffected.

Asymmetrical Link Propagate

In Asymmetrical Link Propagate mode, faults are propagated based on the port notation. Port 1 to Port 2 notation indicates the direction the loss of link signal will propagate. A loss of receive link on the fiber optic Port 1 causes the RJ-45 Port 2 to drop its link due to the propagated state (Port 1 to Port 2). The loss of link on the RJ-45 Port 2 does not cause the loss of link to propagate. The loss only propagates in the Port 1 to Port 2 direction. See Port Configurations on page 4.

NOTE: A loss of link or loss of signal is when the optical receiver on the media converter can no longer detect the presence of an optical signal.

NOTE: On models with 2 fiber ports or 2 RJ-45 ports, both ports of the same media type must be in link fault condition before the fault will propagate.

SW12	SW13	Function
DOWN	DOWN	Link Segment (LS)
UP	DOWN	Asymmetrical Link Propagate Port 1 to Port 2 (1+1 - 2 Port models), Port 1 to Port 2 and Port 3 (1+2 - 3 Port models), Port 1 and Port 2 to Port 3 (2+1 - 3 Port models) and Port 1 and Port 2 to Port 3 and Port 4 (2+2 - 4 Port models).
DOWN	UP	Asymmetrical Link Propagate Port 2 to Port 1 (1+1 - 2 Port models), Port 2 and Port 3 to Port 1 (1+2 - 3 Port models) Port 3 to Port 1 and Port 2 (2+1 - 3 Port models) and Port 3 and Port 4 to Port 1 and Port 2 (2+2 - 4 Port models)
UP	UP	Invalid Configuration

Link Modes

SW14 - Power Sourcing Reset

The OmniConverter can be configured to disable (reset) the PoE output power for 2 seconds after a loss of receive link on any fiber port. This feature is typically used to allow a PD to re-initialize after a failure on the incoming fiber. When this DIP-switch is in the Up “Lk Loss” position, the module will disable PoE output power for 2 seconds following a loss of receive link on any fiber port. When this DIP-switch is in the Down position, PoE output power does not reset on fiber link loss.

SW15 and SW16 - Port Redundant Mode

SW15 and SW16 are valid on models with 2 fiber ports only. Port redundancy is available when connected to Omnitron and third party devices with 2 fiber ports.

SW15 controls the port redundancy mode of the module. When SW15 is in the Down “Off” (default) position, the fiber ports operate in a non-redundant (independent) mode. When SW15 is in the Up “On” position, the fiber ports operate as redundant links. A fault on the primary fiber port (Port 1), will cause a fail over to the secondary fiber port (Port 2) within 50msec.

SW16 enables the module to return to the primary fiber port (Port 1) after the fiber link has been restored for 6 seconds. When SW16 is in the Down “Off” position, return to primary is disabled (inactive). When the SW16 is in the Up “On” position, return to primary is enabled.

Switch 15 P1+P2 Redun	Switch 16 Rtn P1	Function
DOWN (Off)	DOWN (Off)	Non-redundant mode - normal mode
DOWN (Off)	UP (On)	Non-redundant mode - normal mode
UP (On)	DOWN (Off)	Redundant mode - no return to primary
UP (On)	UP (On)	Redundant mode - return to primary

Port Redundancy Modes

2) Installing the Module

Wall Mounting

The wall mounting height of the module should be less than or equal to 2 meters (6.6 feet) from the floor. Use the four mounting holes on the module to secure the module to the wall. The module can accommodate #6 screws (not included).

Installation of the module should be such that the air flow in the front, back, side and top vents of the switch are not compromised or restricted.

The accessory cables should have their own strain relief and do not pull down on the module.

Rack Mounting

The module can be rack mounted using the optional Rack Mount Shelf (8260-0). Refer to the Rack Mount Shelf user manual (040-08260-001x) for the proper installation guidelines.

Follow the same guidelines above when rack mounting the module.

DIN-rail Mounting

The module can be DIN-rail mounted using the optional DIN-rail Mounting Bracket (8250-0) or the optional DIN-rail Mounting Clip (8251-0). Refer to the user manuals (040-08250-001x or 040-08251-001x) for the proper installation guidelines.

3) Apply Power

AC Power

Secure the ground wire to the NEBS grounding screw located on the back of the module.

To power the unit using the AC/DC adapter, route the power cord through the provided strain relief for additional support. Then connect the barrel connector at the end of the wire on the AC/DC adapter to the 2.1mm DC barrel connector (center-positive) on the unit. Connect the AC/DC adapter to the AC outlet. Confirm that the module has powered up properly by checking the Power LED located on the front of the installed module.

Installation of the equipment should be such that the air flow in the front, back, side and top vents of the chassis are not compromised or restricted.

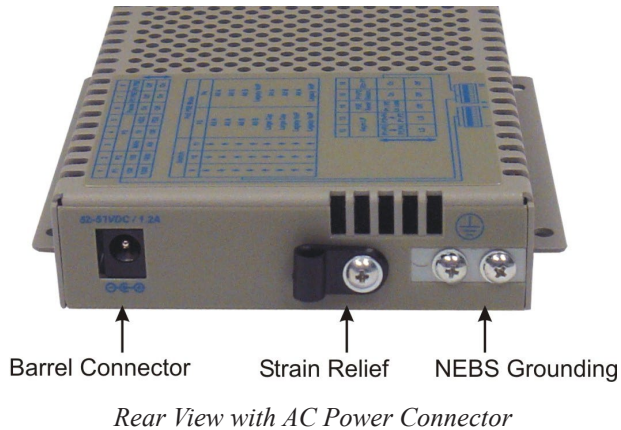

WARNING!!!
NEVER ATTEMPT TO OPEN THE CHASSIS OR SERVICE THE POWER SUPPLY. OPENING THE CHASSIS MAY CAUSE SERIOUS INJURY OR DEATH. THERE ARE NO USER REPLACEABLE OR SERVICEABLE PARTS IN THIS UNIT.

DC Power

This module is intended for installation in restricted access areas. (“Les matériels sont destinés à être installés dans des EMBLEMES À ACCÈS RESTREINT”). A restricted access area can be accessed only through the use of a special key, or other means of security.

The over current protection for connection with centralized DC shall be provided in the building installation, and shall be a UL listed circuit breaker rated 20 Amps, and installed per the National Electrical Code, ANSI/NFPA-70.

Appropriate overloading protection should be provided on the DC power source outlets utilized.

The module requires +46 to 57VDC @ 72mA max rated power. See specification table for specific model requirements.

Description	IEEE 802.3af PoE
Power Supply Voltage Range	46.0 to 57.0 VDC
Voltage Range at PSE port Output	44.0 to 56.0 VDC
Maximum Power from PoE/PSE port	15.4 watts
Minimum Voltage at PoE/PD port input*	37.0 VDC
Minimum Power at PoE/PD port*	12.95 watts
* at 100 meters using Cat5	

WARNING: Only a DC power source that complies with safety extra low voltage (SELV) requirements can be connected to the DC-input power supply.

WARNING REGARDING EARTHING GROUND:

- This equipment shall be connected to the DC supply system earthing electrode conductor or to a bonding jumper from an earthing terminal bar or bus to which the DC supply system earthing electrode is connected.
- This equipment shall be located in the same immediate area (such as adjacent cabinets) as any other equipment that has a connection between the earthed conductor of the same DC supply circuit and the earthing conductor, and also the point of earthing of the DC system. The DC system shall not be earthed elsewhere.
- The DC supply source is to be located within the same premises as this equipment.
- There shall be no switching or disconnecting devices in the earthed circuit conductor between the DC source and the earthing electrode conductor.

Locate the DC circuit breaker of the external power source, and switch the circuit breaker to the OFF position.

Prepare a power cable using a three conductor insulated wire (not supplied) with 12AWG to 14AWG thickness. Cut the power cable to the length required.

Strip approximately 3/8 of an inch of insulation from the power cable wires.

Connect the ground wire to the NEBS grounding screws on the back of the module.

Route the power cables through the provided strain relief for additional support. Connect the power cables to the module by fastening the stripped ends to the DC power connector.

WARNING: Note the wire colors used in making the positive, negative and ground connections. Use the same color assignment for the connection at the circuit breaker.

Connect the power wires to the circuit breaker and switch the circuit breaker ON. If any module are installed, the Power LED will indicate the presence of power.

During the installation, ensure that the ground potentials are maintained throughout the system connections. This includes but not limited to the power source ground and any shielded cabling grounds.

Installation of the equipment should be such that the air flow in the front, back, side and top vents of the chassis are not compromised or restricted.

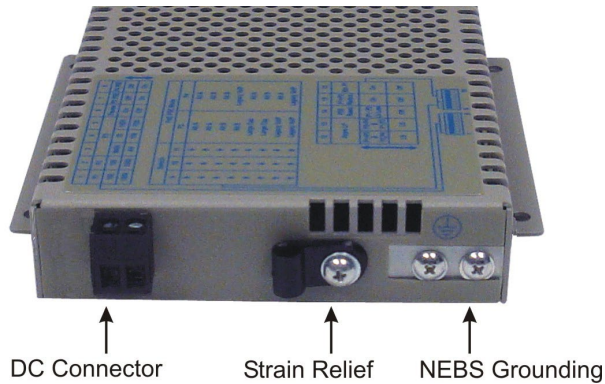

Rear View with DC Power Connector

WARNING!!!
NEVER ATTEMPT TO OPEN THE CHASSIS OR SERVICE THE POWER SUPPLY. OPENING THE CHASSIS MAY CAUSE SERIOUS INJURY OR DEATH. THERE ARE NO USER REPLACEABLE OR SERVICEABLE PARTS IN THIS UNIT.

4) Connect Cables

- a. When using the SFP model, insert the SFP Fiber transceiver into the SFP receptacle on the front of the module (see the SFP Data Sheet 091-17000-001 for supported Fast Ethernet transceivers).

NOTE: The release latch of the SFP Fiber transceiver must be in the closed (up) position before insertion.

- b. Connect an appropriate multimode or single-mode fiber cable to the fiber port on the front of the module. It is important to ensure that the transmit (TX) is attached to the receive side of the device at the other end and the receive (RX) is attached to the transmit side. When using single-fiber (SF) models, the TX wavelength must match the RX wavelength at the other end and the RX wavelength must match the TX wavelength at the other end.
- c. Connect the Ethernet 10/100 RJ-45 port via a Category 5 or better cable to an external 10BASE-T or 100BASE-TX Ethernet device.

5) Verify Operation

Verify the Module is operational by viewing the LED indicators.

Power LED Indicators		
Legend	Indicator	Description
Pwr	OFF	Unit not powered
	Green - ON	Unit powered
	Amber - ON	Over temperature condition

Power LED Indicators

Fiber Port LED Indicators		
Legend	Indicator	Description
P1	OFF	No link
	Green - ON	Port linked at 100Mbps
	Green - Blinking at 10Hz	Port data activity at 100Mbps
	Green - Blinking at 1Hz	Port linked at 100Mbps and in redundant standby mode
	Amber - Blinking at 1Hz	Port linked at 100Mbps and receiving Far End Fault Indicator (FEFI)
FDX	OFF	Port is in half-duplex
	Green - ON	Port is in full-duplex
Stat	OFF	Transceiver does not support digital diagnostics or no transceiver (SFP) is installed
	Green - ON	Transceiver (SFP) supports digital diagnostics and no alarm is detected
	Amber - ON	Transceiver (SFP) supports digital diagnostics and alarms are present
P2	OFF	No link
	Green - ON	Port linked at 100Mbps
	Green - Blinking at 10Hz	Port data activity at 100Mbps
	Green - Blinking at 1Hz	Port linked at 100Mbps and in redundant standby mode
	Amber - Blinking at 1Hz	Port linked at 100Mbps and receiving Far End Fault Indicator (FEFI)
FDX	OFF	Port is in half-duplex
	Green - ON	Port is in full-duplex
Stat	OFF	Transceiver does not support digital diagnostics or no transceiver (SFP) is installed
	Green - ON	Transceiver (SFP) supports digital diagnostics and no alarm is detected
	Amber - ON	Transceiver (SFP) supports digital diagnostics and alarms are present

Fiber LED Indicators

RJ-45 Port Indicators		
Legend	Indicator	Description
10	OFF	No link
	Green - ON	Port linked at 10Mbps
	Green - Blinking at 10Hz	Port data activity at 10Mbps
	Amber - Blinking at 1Hz	Port linked at 10Mbps and receiving AN Remote Fault
100	OFF	No link
	Green - ON	Port linked at 100Mbps
	Green - Blinking at 10Hz	Port data activity at 100Mbps
FDX	Green - ON	Port is configured for full-duplex via DIP-switch or has negotiated to full-duplex in AN mode
	OFF	Port is configured for half-duplex via DIP-switches or Port 2 has negotiated to half-duplex in AN mode or Port 2 in AN mode has not established the correct connection
PSE	Green - ON	Port PSE is active
	Amber - ON	Port PSE inactive
	Amber - Blinking at 1Hz	Port PSE inactive due to resistance too low (< 15k ohms) or short circuit detected
	Amber - Blinking at 10Hz	Port PSE inactive due to resistance too high (33k to 500k ohms)
	OFF	Port PSE disabled

RJ-45 LED Indicators

Specifications

Description	OmniConverter FPoE/SL 10/100BASE-T to 100BASE-X Fiber Media Converter with PoE	
Standard Compliances	IEEE 802.3, IEEE 802.3af (15.40 watts)	
PoE Supported Modes	IEEE Alternate A (Alt A) and B (Alt B) Cisco Legacy and High Cap (Alt B, Legacy & High Cap requires 9143-6 cable)	
Environmental	REACH, RoHS and WEEE	
Frame Size	Up to 2,000 bytes	
Port Types	Copper: 10/100BASE-T (RJ-45) Fiber: 100BASE-X (ST, SC, SFP) 100BASE-BX (SC, SFP)	
Cable Types	Copper: EIA/TIA 568A/B, Cat 5 UTP and higher Fiber: Multimode: 50/125, 62.5/125µm Single-mode: 9/125µm	
AC Power Requirements (Models with AC/DC Adapters)	1 RJ-45 Port: 100 - 240VAC/47 to 63Hz 0.17A @ 120VAC (typical)	2 RJ-45 Ports: 100 - 240VAC/50 - 60Hz 0.32A @ 120VAC (typical)
DC Power Requirements (Models with DC Terminals)	1 RJ-45 Port: +46 to +57VDC; 0.39A @ 48VDC 2 Pin Terminal (non-isolated)	2 RJ-45 Ports: +46 to +57VDC; 0.72A @ 48VDC 2 Pin Terminal (non-isolated)
	A minimum DC input voltage of 50VDC is required to guarantee 25.5 watts (for 802.3at) at the end of 100 meters on Cat 5 cable or better.	
Dimensions (W x D x H)	4.5" x 6.0" x 1.0" (114.3 mm x 152.4 mm x 25.4 mm)	
Weight	Module: 1.1 lbs. (498.9 grams) With AC/DC Adapter: 1.6 lbs. (725.7 grams)	
Operating Temperature	Commercial: 0 to 50°C Wide: -40 to 60°C (-20°C AC cold start) Extended: -40 to 75°C (-20°C AC cold start) Storage: -40 to 80°C	
Humidity	5 to 95% (non-condensing)	
Altitude	-100m to 4,000m	
MTBF (hrs)	Module: 430,000 AC/DC Adapter: 100,000	
Warranty	Lifetime warranty with 24/7/365 free Technical Support	

Regulatory Compliances (*Pending)	Safety:	UL 62368-1*, UL 60950-1, IEC 62368-1*, IEC 60950-1, EN 62368-1*, EN 60950-1, CAN/CSA C22.2 No. 62368-1-14*, CAN/CSA C22.2 No. 60950-1, CE Mark
	EMC:	EN 55032/EN 55024 CE Emissions/Immunity
	EMI:	CISPR 32, FCC 47 Part 15 Subpart B Class A
	IP Rating:	IP20 Protection

Appendix A: Link Modes

1 Fiber 1 UTP Models

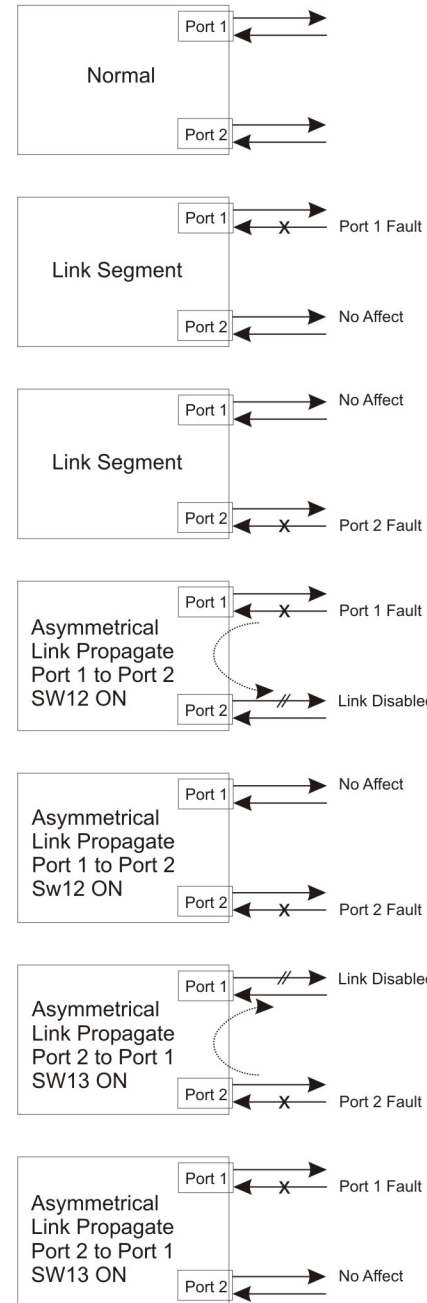

1 Fiber 2 UTP Models

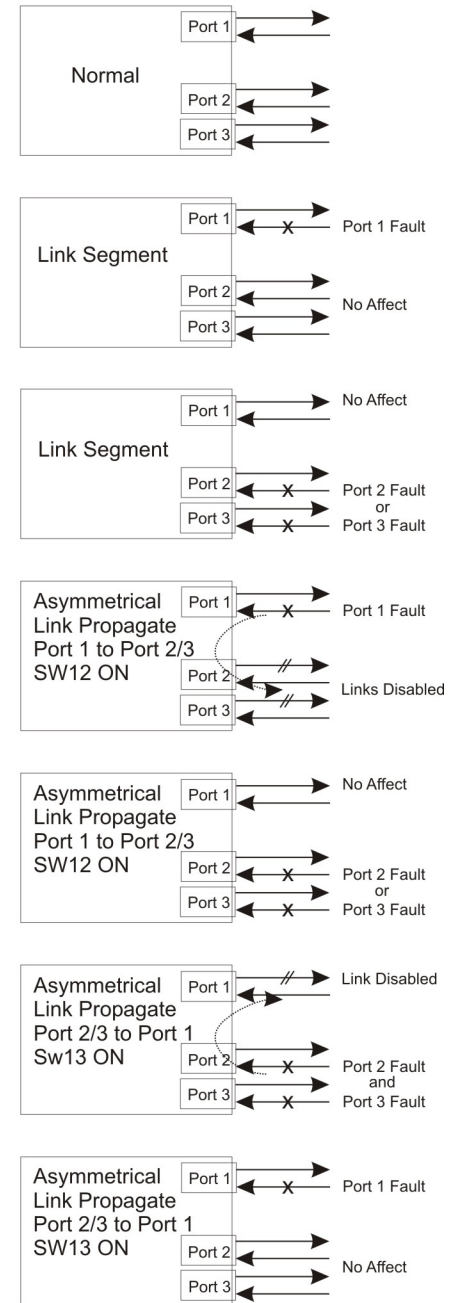

2 Fiber 1 UTP Models

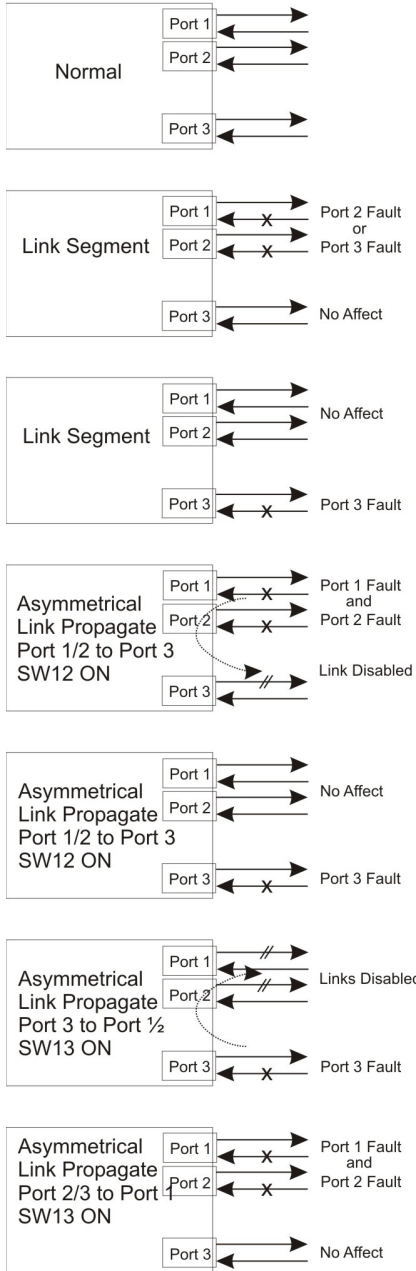

2 Fiber 2 UTP Models

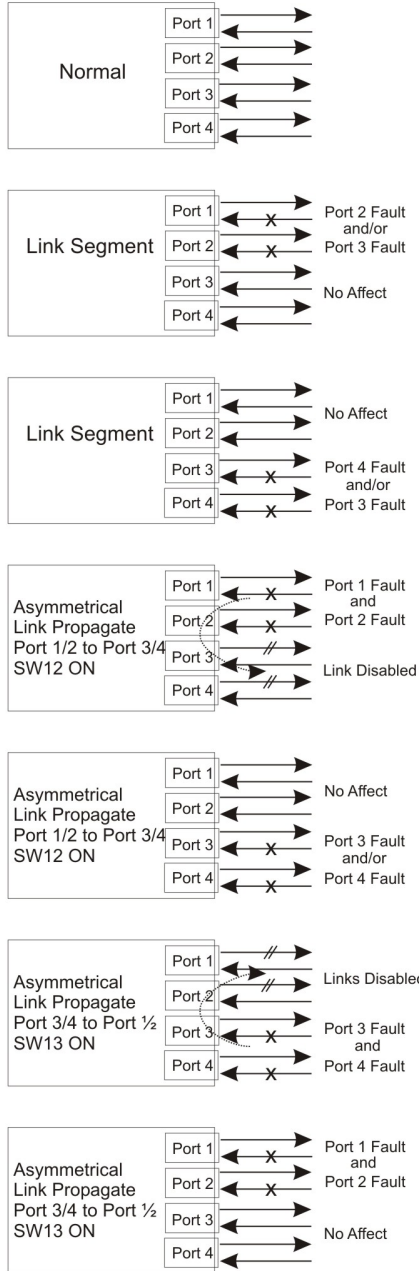

Page intentionally left blank