

### **iConverter® Single Fiber CWDM Multiplexers and Add/Drop OADM MUX/DEMUX and Optical Add/Drop OADM Modules**

iConverter Single-Fiber Course Wave Division Multiplexing (CWDM) modules provide a flexible and cost-effective solution for increasing the fiber capacity of single fiber networks. Up to ten separate data channels can be transported on a single-fiber link with iConverter Single-Fiber CWDM modules.

The iConverter CWDM/X and CWDM/AD single-fiber modules are protocol and rate transparent allowing different services up to 10Gbps to be transported across the same common fiber link. The single-fiber modules support dual fiber Channel Ports and single-fiber Common Port connections. Each fiber strand on the Channel Port supports a different wavelength, one wavelength for transmit (TX) and a different wavelength for receive (RX).

#### **Single-Fiber CWDM/X Multiplexer/Demultiplexer Modules**

Single-Fiber iConverter CWDM/X modules are available in 2, 4 and 5-Channel models, supporting a variety of wavelength combinations and port configurations. In point-to-point applications, the CWDM/X modules operate in pairs, maximizing the number of wavelengths supported.

The Single-Fiber iConverter 5-Channel CWDM/X modules support five bidirectional wavelengths channels between 1431nm to 1611nm with a 1310nm Pass Band Port. An optional Optical Time Domain Reflectometer (OTDR) port is available which provides the ability to test the integrity of the fiber optic link without disturbing the wavelength channels.

The 5-Channel CWDM models also support up to ten unidirectional data channels for data/video overlay networks.

#### **Single-Fiber CWDM/AD Add & Drop Multiplexers**

iConverter 1-Channel Single-Fiber CWDM/AD modules are CWDM Optical Add and Drop Multiplexers (OADM). The CWDM/AD modules add (multiplex) and drop (de-multiplex) one channel on one or both directions of a CWDM single-fiber link. Nine standard models of the 1-Channel Single-Fiber CWDM/AD modules are available.

iConverter CWDM/AD modules add new access points anywhere on a single-fiber CWDM network, without impacting the remaining channels traversing the network. Access points can be added to linear, bus, and ring networks, where the dual-direction ring design provides redundant protected architecture.



### **KEY FEATURES**

#### **iConverter Single-Fiber CWDM/X**

- 2, 4 and 5-Channel MUX/DEMUX modules
- 2 and 4-Channel modules are scalable to 4 or 8 Channels using a Band Splitter module
- 5-Channel modules support five bidirectional or ten unidirectional data channels

#### **iConverter Single-Fiber CWDM/AD**

- 1-Channel Optical Add and Drop Multiplexers modules
- Add and Drop functions in both directions

#### **Common Product Features**

- Protocol and rate transparent for applications up to 10Gbps
- Minimal and uniform optical loss facilitates easy network planning
- Industry standard LC connectors
- Highly compact form factor
- Seamless integration with other iConverter media converters and chassis for multi-service platforms
- Compatible with OmniLight® chassis using the iConverter LGX Adapter
- Passive device that can be installed in a powered chassis for managed applications
- Made in the USA
- One (1) Year Warranty and Free 24/7 Technical Support

# APPLICATION EXAMPLES

## Linear Add/Drop

In this application, 1-Channel SF OADMs and a 4-Channel SF MUX/DEMUX module creates a linear network dropping services off to four sites on a single-fiber common link.

At the headend, a 4-Channel single-fiber MUX/DEMUX is used to connect four Ethernet switches each supporting two wavelengths over a common fiber link. At the first site, a 1-Channel OADM is installed to remove and add the 1470/1490nm wavelength which is associated with Network A. The remaining wavelengths (1510/1530nm,

1550/1570nm and 1590/1610nm) are passed through the OADM to the next site.

The 1510/1530nm wavelength associated with Network B is dropped at the second site while the 1550/1570nm and 1590/1610nm wavelengths are passed on to the last two sites. The 1550/1570nm wavelength associated with Network C is dropped at the third site. Since only 4 channels are used, the last site does not need a OADM module.

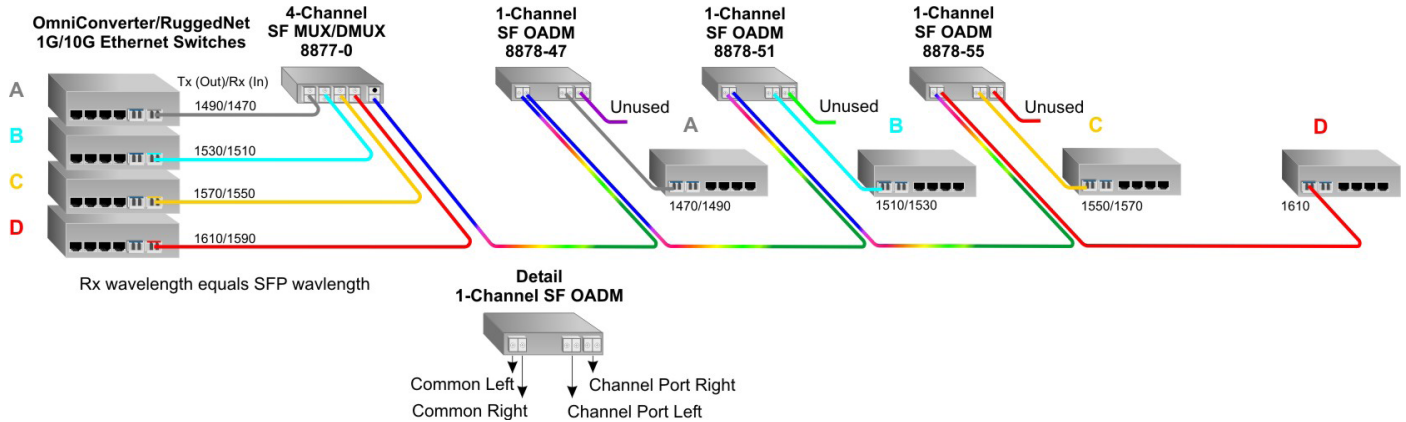

## Basic Application Diagrams

Below are block diagrams representing a 4-Channel CWDM Single-Fiber point-to-point application and a 4-Channel CWDM Single-Fiber point-to-point with an OADM somewhere in between the 4-Channel MUXs.

All Single-Fiber modules have dual fiber channel ports and single-fiber common ports. The CWDM SFP transceiver wavelength required for any single-fiber application depends on the Rx wavelength of the Single-Fiber module.

In the 4-Channel point-to-point diagram below, the CWDM SFP transceiver wavelength needed for Channel 1 of the 8877-0 module is 1470nm.

In the 4-Channel point-to-point with OADM, the CWDM SFP transceiver wavelength needed for the OADM Channel 1 Left is 1490nm and for Channel 1 Right is 1470nm.

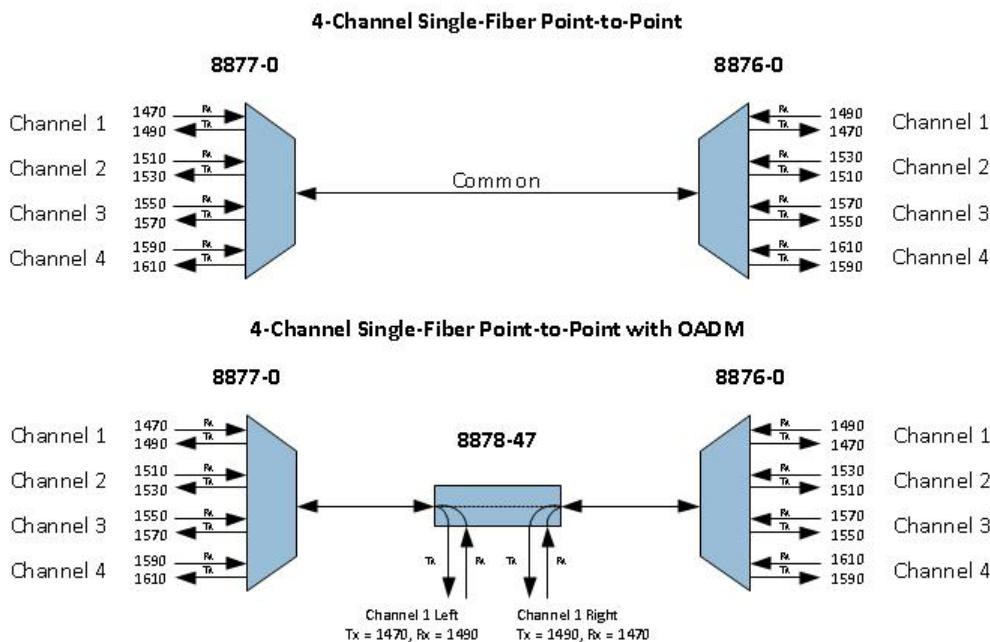

# SPECIFICATIONS

Optical Characteristics		
Parameter	Units	Values
Common Port (5-Channel) Operating Wavelength	nm	1260 - 1660
Common Port (All Others) Operating Wavelength	nm	1270 - 1610
CWDM Center Channel	nm	1271, 1291, 1311, 1331, 1351, 1371, 1431, 1451, 1431, 1451, 1471, 1491, 1511, 1531, 1551, 1571, 1591, 1611
CWDM Channel Spacing	nm	20
1310 Pass Band	nm	1270 - 1350
1310 Pass Band Width	nm	± 6.5
Ripple over Pass Band	dB	≤ 0.5
OTDR	nm	1625 - 1660
1-Channel OADM Insertion Loss	dB	< 1.9
2-Channel MUX Insertion Loss	dB	< 1.9
4-Channel MUX Insertion Loss	dB	< 2.4
5-Channel MUX Insertion Loss	dB	Typical 1.6 to 4.4, Max 2.3 to 5.0
1310 Pass Band Insertion Loss	dB	Typical 0.8, Max 1.0
OTDR Insertion Loss	dB	Typical 1.4, Max 2.5
Adjacent Channel Isolation	dB	> 30
Non-Adjacent Channel Isolation 1, 2, and 4-Channel	dB	> 40
Non-Adjacent Channel Isolation 5-Channel	-	> 45
Return Loss (filtered channel)	dB	≥ 45

Description		<i>i</i> Converter CWDM/X and CWDM/AD
Description		Single-Fiber CWDM MUX/DEMUX and ADD/DROP
Regulatory Compliances		Telecordia GR-1209, GR-1221 UL, CE, RoHS, WEEE, REACH
Port Types		Fiber: LC (UPC)
Cable Types		Fiber: Single-mode: 9/125µm Channel Ports: Dual Fiber Common Port: Single-Fiber
DC Power Requirements		DC Input (backplane): 3.3VDC, 0.025A @ 3.3VDC (when management is required, otherwise passive operation)
Dimensions W x D x H		0.85" x 4.5" x 2.8" (21.6 mm x 114.3 mm x 71.1 mm)
Weight		12 oz. (340.2 grams)
Temperature		Commercial: 0 to 50°C Wide: -40 to 60°C Storage: -40 to 80°C
Humidity		5 to 95% (non-condensing)
Altitude		-100m to 4,000m
MTBF (hrs)		> 1,000,000
Warranty		One (1) year warranty with 24/7/365 free Technical Support

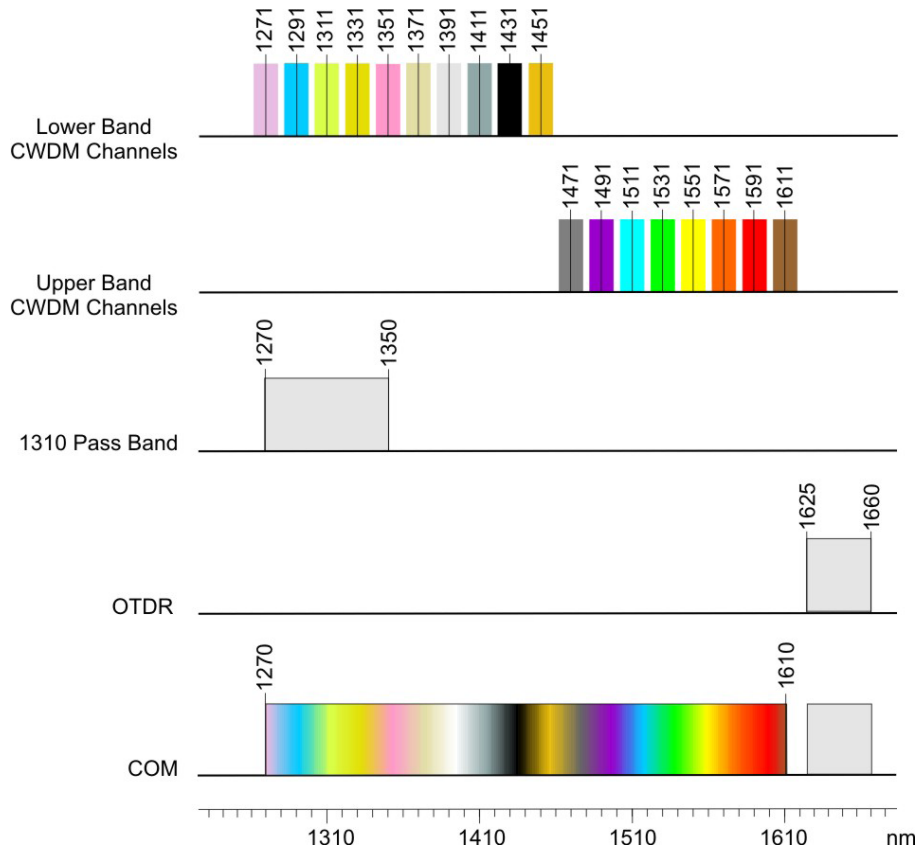

# ORDERING INFORMATION

Model Number	Model Type	Channel Port ITU Center Wavelengths (nm) Tx (Out) / Rx (In)
8870-0t	2-Channel MUX/DEMUX with LC UPC Connectors	Channel 1 = 1471/1491, Channel 2 = 1511/1531
8871-0t	2-Channel MUX/DEMUX with LC UPC Connectors	Channel 1 = 1491/1471, Channel 2 = 1531/1511
8872-0t	2-Channel MUX/DEMUX with LC UPC Connectors	Channel 1 = 1551/1571, Channel 2 = 1591/1611
8873-0t	2-Channel MUX/DEMUX with LC UPC Connectors	Channel 1 = 1571/1551, Channel 2 = 1611/1591
8874-0t	4-Channel MUX/DEMUX with LC UPC Connectors	Channel 1 = 1271/1291, Channel 2 = 1311/1331, Channel 3 = 1351/1371, Channel 4 = 1431/1451
8875-0t	4-Channel MUX/DEMUX with LC UPC Connectors	Channel 1 = 1291/1271, Channel 2 = 1331/1311, Channel 3 = 1371/1351, Channel 4 = 1451/1431
8876-0t	4-Channel MUX/DEMUX with LC UPC Connectors	Channel 1 = 1471/1491, Channel 2 = 1511/1531, Channel 3 = 1551/1571, Channel 4 = 1591/1611
8877-0t	4-Channel MUX/DEMUX with LC UPC Connectors	Channel 1 = 1491/1471, Channel 2 = 1531/1511, Channel 3 = 1571/1551, Channel 4 = 1611/1591
8880-1t	5-Channel MUX/DEMUX and 1310 Pass Band with LC UPC Connectors	Channel 1 = 1431/1451, Channel 2 = 1471/1491, Channel 3 = 1511/1531, Channel 4 = 1551/1571, Channel 5 = 1591/1610
8880-2t	5-Channel MUX/DEMUX, 1310 Pass Band and OTDR with LC UPC Connectors	Channel 1 = 1431/1451, Channel 2 = 1471/1491, Channel 3 = 1511/1531, Channel 4 = 1551/1571, Channel 5 = 1591/1610
8878-λt	1-Channel Add/Drop Lower Band with LC UPC Connectors	λ = 27 (1271/1291), 31 (1311/1331), 35 (1351/1371), 39 (1391/1411), 43 (1431/1451)
8878-λt	1-Channel Add/Drop Upper Band with LC UPC Connectors	λ = 47 (1471/1491), 51 (1511/1531), 55 (1551/1571), 59 (1591/1611)

Single-fiber CWDM/X models must be used in pairs. The Tx wavelengths on one end has to match the Rx wavelengths on the other.

For the 1-Channel OADMs, the Channel Port Left wavelengths are shown in the table above. Channel Port Right wavelengths are reversed from Channel Port Left.

1-Channel Lower Band OADM Example: For wavelength 1351/1371, λ = 35, 8878-35

1-Channel Upper Band OADM Example: For wavelength 1551/1571, λ = 55, 8878-55

### Base Model Number: 88xx-xt

Select the model with wavelength requirement from ordering table above.

Add operating temperature range (t) to the model type selected.

### Operating Temperature Options (t):

<leave blank> = Commercial temperature (0 to 50°C)

W = Wide temperature (-40 to 60°C)

Contact Omnitron for other port configurations, extended temperature (-40 to 75°C) and RoHS (5/6) compliant models.

See chassis and mounting options at: [Converter Chassis and Mounting Option web page.](#)

### Logical Diagrams

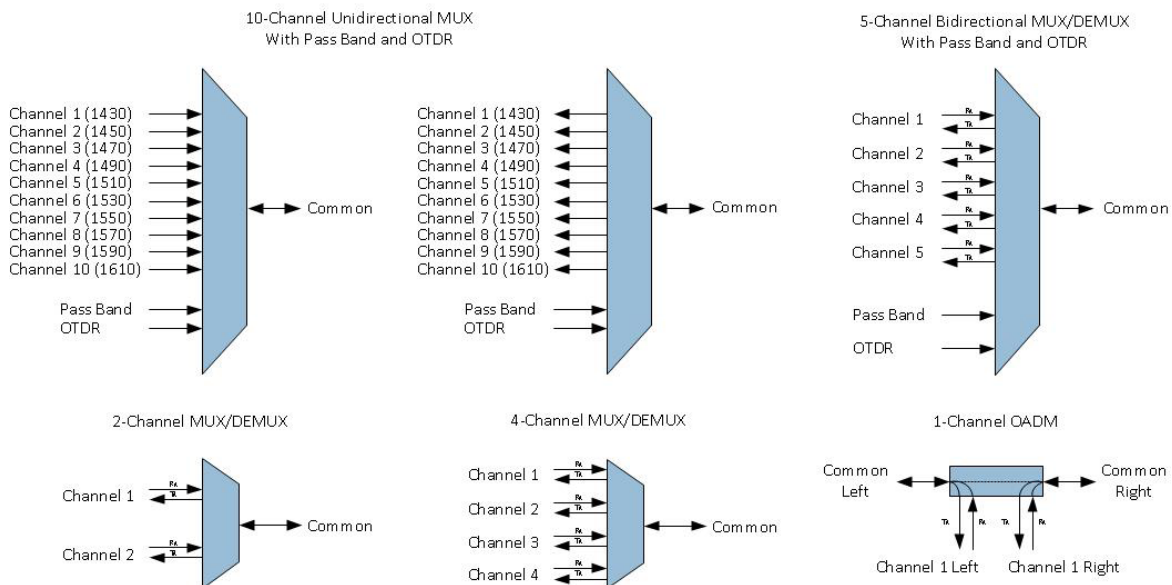

© 2021 Omnitron Systems Technology, Inc. All rights reserved. iConverter and OmniLight are registered trademarks of Omnitron Systems Technology, Inc. LGX is a registered trademark of AT&T. Trademarks are owned by their respective companies. Specifications subject to change without notice.

