

FlexPoint™ and *iConverter*®
Fiber Media Converter
Product Family

FlexPoint 10FL/2 and *iConverter* 10FL/2
Discontinued and Replacement Model

Document Number: 002-A0012
Version A
March 2023

Omnitron Systems Technology, Inc.
38 Tesla
Irvine, CA 92618
tel: (949) 250-6510
www.omnitron-systems.com

1.0 SCOPE

This application note describes the alternate replacement bundled solution to the discontinued iConverter 10FL/2 and FlexPoint 10FL/2 models.

2.0 AFFECTED MODELS

The following table lists the model numbers of the discontinued and the replacement models.

Product Family	Product Name	Discontinued Models	Replacement Models
FlexPoint	10FL/2 MM/DF 2km ST	4310	4300 and 4320
	10FL/2 MM/DF 5km ST	4312	4302 and 4320
	10FL/2 SM/DF 30km ST	4311	4301 and 4320
Product Family	Product Name	Discontinued Models	Replacement Models
iConverter	10FL/2 MM/DF 2km ST	N/A	8300-0, 8340 and 8230
	10FL/2 MM/DF 2km SC	N/A	8302-0, 8340 and 8230
	10FL/2 MM/DF 5km ST	N/A	8300-1, 8340 and 8230
	10FL/2 SM/DF 30km ST	N/A	8301-1, 8340 and 8230
	10FL/2 SM/DF 30km SC	N/A	8303-1, 8340 and 8230
	10FL/2 SM/DF 30km LC	N/A	8307-1, 8340 and 8230
	10FL/2 SM/DF 60km ST	N/A	8301-2, 8340 and 8230
	10FL/2 SM/DF 60km SC	N/A	8303-2, 8340 and 8230
	10FL/2 SM/DF 60km LC	N/A	8307-1, 8340 and 8230
	10FL/2 SM/DF 120km SC	N/A	8303-3, 8340 and 8230
	10FL/2 SM/SF 20km SC	N/A	8310-1, 8340 and 8230
	10FL/2 SM/SF 20km SC	N/A	8311-1, 8340 and 8230
	10FL/2 SM/SF 40km SC	N/A	8310-2, 8340 and 8230
	10FL/2 SM/SF 40km SC	N/A	8311-2, 8340 and 8230

MM = Multimode, SM = Single-mode, DF = Dual Fiber, SF = Single-Fiber

Model Number Comparison

3.0 BUNDLED SOLUTIONS

3.1 iConverter Bundle Solution

The bundled solution consists of the iConverter 10FL/T, 10T/2 and 2-Module Chassis (8230). The module will have external connections for the fiber, coax and Cat 5 cabling.

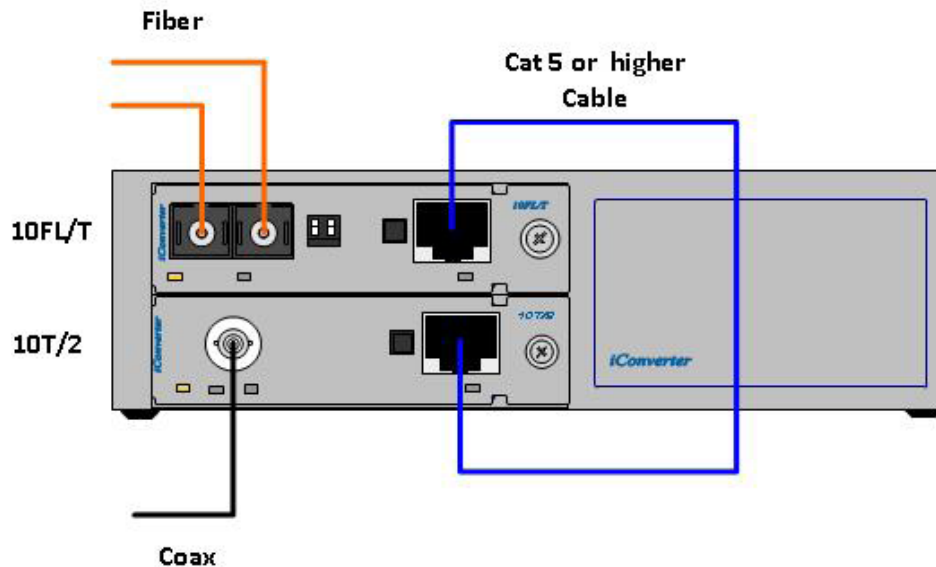

iConverter 10FL/2 Solution

Note: RJ-45 Cable is not included in the bundled solution.

This bundled solution can also be installed in a 19-Module and 5-Module chassis.

For a managed solution, the modules can be installed in a 19 or 5-Module chassis with a [Network Management Module \(NNM2\)](#).

The 2-Module chassis can be wall/rack mounted by attaching the optional wall/rack mount brackets (8249-0). A 19" Rack Mount Shelf (8260-0) is available to install three 2-Module chassis. Refer to the [User Manual for the 2-Module Chassis](#) for more information.

3.2 FlexPoint Bundled Solution

The FlexPoint replacement requires the 10FL/T and 10T/2 modules to be mounted next to each other. This solution requires a Cat 5 or higher cable to be connected to the RJ-45 ports on the modules, as well as a fiber and coax cables.

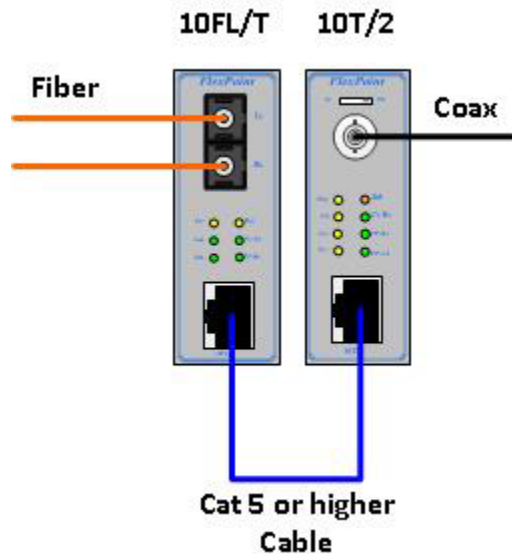

FlexPoint 10FL/2 Solution

Note: RJ-45 Cable is not included in the bundled solution.

The FlexPoint modules can be wall-mounted using a wall mounting kit (4380), rack-mounted using a 5-Module shelf (4392) or inserted in a 14-Module FlexPoint Powered Chassis. Refer to the appropriate [User Manual](#) for more information.